

# optima fd30



## Innovative Solutions

to Access and Fire Safety 2010

### Halspan Fabrication

- > Doorsets
- > Frames
- > Doors
- > Acoustic Doors
- > Glass
- > Fire Doors

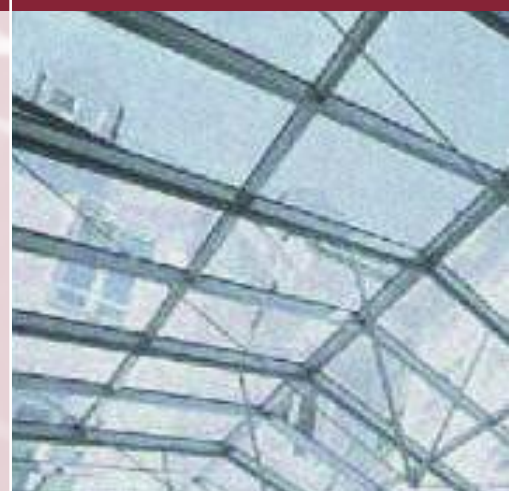

## Technical Support Manual

Halspan Optima

**HALSPAN**<sup>®</sup>

[www.halspan.com](http://www.halspan.com)

## Introduction

An Introduction to Fire Doors.....3

Introducing Halspan – BM TRADA Q Mark.....4

**Optima**

Halspan Optima Technical Overview .....5

Fabrication .....6

Finishes .....7

## 1 Halspan FD30 Specification Timber & MDF Frames

Timber & MDF Frame Profiles.....8

Door gaps, Lipping Details – Single Action .....9

Door gaps, Lipping Details – Double Action .....10

Door gaps, Lipping Details – Single/Double action/Overpanels .....11

## 2 Halspan FD30 Permitted Sizes, Configurations Intumescent Seal Details, Timber & MDF Frames

Latched Single Action Single .....12

Unlatched Single Action Single .....13

Double Action Single.....14

Latched Single Action Double.....15

Unlatched Single Action Double.....16

Double Action Double.....17

Latched Single Action Single & Overpanel.....18

Unlatched Single Action Single & Overpanel .....19

Double Action Single & Overpanel .....20

Latched Single Action Double & Overpanel .....21

Unlatched Single Action Double & Overpanel .....22

Double Action Double & Overpanel .....23

### Aluminium Frames

Introduction – Installation .....24

**Permitted sizes, configurations, Intumescent seal detail**

Single Doors .....25

Double Doors.....26

## 3 Mechanical Performance

Testing & Performance.....27

<b>4 Acoustic Performance</b>	
General Acoustic Information .....	28
<b>5 Ironmongery</b>	
Hinges .....	29
Latches and Locks .....	30
Door Closers .....	31
Bolts and Floor Springs .....	32
Non-essential Ironmongery .....	33
<b>6 Glazing</b>	
Introduction .....	35
Glazing Schemes .....	37
Guide to beading detail .....	39
<b>7 Safety Data</b>	
Handling and storage .....	44
Transport Considerations .....	44
Health Hazards .....	44
Fire and Explosion .....	45
First Aid .....	45
Installation Guide .....	46

## AN INTRODUCTION TO FIRE DOORS WHAT FIRE DOOR TESTING IS ABOUT

Test standards are designed to evaluate the 'fire resisting' capabilities of doorsets. Tests are conducted by 'Approved' bodies whose Test Reports and Assessments formally confirm the integrity of a fire door (e.g. FD30 & FD60).

These documents are the primary source of information summarised in Halspan manuals and literature to aid customers making doors from Halspan.

A brief summary of testing follows.

### THE REAL FIRE SITUATION

Following full flashover, gases already present in the room will be heated, and thus expand, creating a greater pressure than is present outside.

At the same time, combustion processes create additional gases, adding to the imbalance or over-pressure and the combination of hot gases rises to the upper zone of the room.

Continuing, the combustion seeks more oxygen to maintain the process, which is drawn into the room through gaps at the lower zone, creating a slightly negative pressure in this area.

### HOW THE TEST IS CONDUCTED

This pressure regime fire test is considered appropriate because it replicates natural conditions similar to this experienced in a real fire.

The test is performed with a positive pressure within the upper part of a furnace. Such pressure forces the hot furnace gases through gaps or joints in the assembly which are essential for movement in normal service, especially those gaps between door leaf and frame. Invariably, it is as a result of these hot gases that integrity failure occurs.

To pass the rigorous standard of the tests, a similarly high standard of design and specification is essential. That includes the performance of intumescent materials which seal gaps and reduce thermal transfer.

### SIMILAR APPLICATION ELSEWHERE

The same testing principle is included in the International Standard ISO 834, which forms the basis of many tests in other countries.

### TEST RESULTS—WORKING IN PRACTICE

Fire resisting doors are rarely supplied in an identical form to that which was tested. The specification will invariably require the door to be supplied at a size, in a mode, with glazing openings, glass and ironmongery that are different to that tested. These variations in configuration and construction are covered by a judgement or expert opinion in the form of an Assessment issued by the approving body, within the guidelines of BS ISO/TR 12470: 1998, and /or The Fire Test Study Group Resolution No 82 2001.

### HALSPAN SERVICE—WORKING FOR YOU

Where a project specification is more demanding than published data would suggest, Halspan Technical Support service is available on request to help provide further solutions to customer' needs.

## INTRODUCING HALSPAN

Halspan 3-layer particle board has been designed for use in the fabrication of solid core doors. A complex combination of chemical and engineering development has resulted in the superior quality and strength of Halspan high performance timber door blanks. Produced on one of the world's most advanced CPS systems ensure continuity of quality for the product. It is this expertise that sets Halspan above other door constructions.

Halspan door blanks have been ready tested for use in the manufacture of fire doors.

By using Halspan in the construction of flush or panelled doors, Halspan's pre-test programme readily enables the inclusion of fire doors of the same style and finish as the standard, non-fire door specification.

These high standards, applied in making Halspan door blanks, also apply to Halspan's technical support. Literature and advice provide a continuity of quality right through, from manufacture to installation. Always ensuring the highest standards for you and your customer.

## INDEPENDENT VERIFICATION

Reassures customers on the consistent quality of products they specify or use.

BM Trada, IFC Certification and Certifire provide such schemes for fire doors.



## THE HALSPAN PROPOSITION

Specialist joiners and fabricators can use Halspan door blanks in the manufacture of Q-Marked doorsets.

With Halspan there are production and cost benefits, added factors to help smaller firms quote for new business.

## HALSPAN DUTY OF CARE

Halspan achieved the highest grading in the British Standard of Mechanical Tests for 'hinged or pivoted doors' – Severe Duty: Subject to frequent violent usage. Further more, Halspan has already tested with good results to the new, more aggressive EU standard. Over the next three to five years it is likely that the new EN 1634 will be adopted, and BS476: Part 22 withdrawn.

Whether for today or for planning ahead, specifying Halspan products ensures we all can meet the highest standards and our obligations.

## FSC CERTIFICATION

Halspan® door blanks are FSC COC Certified.



**Refer to separate Halspan data sheet for full environmental information.**

## HALSPAN OPTIMA FD30 PRODUCT MATRIX

Characterisation		Characterisation		
<b>Non-Fire Rated</b>		<b>Features</b>		
44mm	✓	<b>Glazing Areas</b>		
54mm	✓	FD30	1.29m <sup>2</sup>	
<b>Fire</b>		Paint finish	✓	
44mm FD30	✓	Weight (Avge density kg/m <sup>3</sup> )	620±10	
<b>Door Frames</b>		Weight (Avge weight kg/m <sup>2</sup> )	27.2	
MDF FD30	✓	Mechanical (Duty grade)	Severe	
Aluminium FD30	✓	Acoustic Performance	Tested	
Softwood FD30	✓	<b>*Board Sizes (44mm) Stock</b>		
Hardwood FD30	✓	2060 x 840mm	✓	
<b>Lipping Glue Lines</b>		2135 x 915mm	✓	
PVA	✓	2440 x 1220mm	✓	
PVAC	✓	2800 x 915mm	✓	
U/F	✓	<b>Identification</b>	 <p>Halspan Optima Look for the ● on the pack label.</p>	
PU	✓			
<b>Minimum Lipping Section/details</b>				
FD30	6mm	<b>Specials</b>		
Rebates (double door etc)	✓	Size – Length x width (min 1 trailer)	✓	
<b>Door set Configurations</b>				
LSASD	✓	<div style="border: 1px solid black; padding: 5px; width: fit-content;"> <p>*NOTE REFER TO SPECIFICATION SHEETS FOR APPROVED FIRE RATED SIZES</p> </div>		
LSASD + OP	✓			
ULSASD	✓			
ULSADD + OP	✓			
DASD	✓			
DASD + OP	✓			
LSADD	✓			
LSADD + OP	✓			
ULSADD	✓			
ULSADD + OP	✓			
DADD	✓			
DADD + OP	✓			
<b>Standard Intumescent</b>				
Palusol FD30	✓			
Graphite FD30	✓			

**HALSPAN**<sup>TM</sup>

OPTIMA CHARACTERISTICS

## FABRICATION & SPECIFICATION

### INTRODUCTION

Halspan Optima door blanks are made in a 3-layer particle board.

The density (monolithic structure) and surface finish of Halspan permits the construction of doors without the need for perimeter framing or the addition of plywood or MDF faces.

It is manufactured specifically with doors in mind, ideal as a solid core timber door, better to make and veneer or laminate.

In addition, Halspan high performance door core has been pre-tested for the fabrication of fire doors.

Using Halspan brings a flexibility, resulting from a continual programme of development and testing, which increasingly meets the needs of designers, in particular an extensive range of glazing options.

### CONSTRUCTION

#### STANDARD METHOD

This manual serves to define the production requirements in order to achieve and maintain the fire integrity of a fire door using Halspan 44mm door blanks.

### ADHESIVE

Bond using Urea Formaldehyde, Cascamite, PVA, PU, HOT Melt, Phenol Formaldehyde.

#### Using Halspan 44mm Door Blanks

To construct FD30 solid core timber

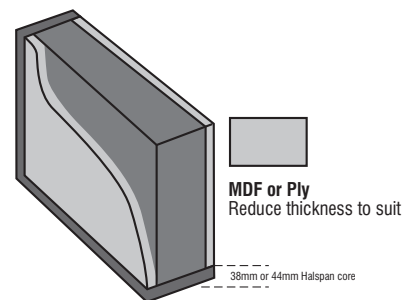
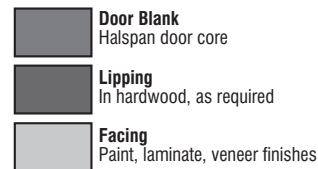
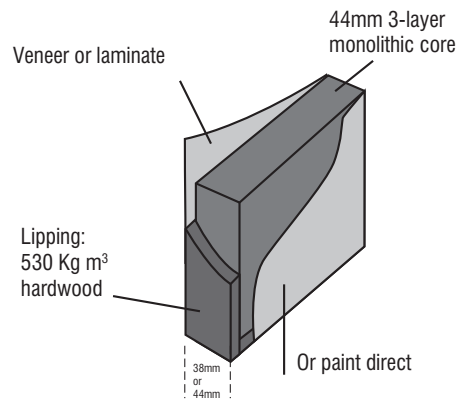

### STRUCTURAL OPENINGS

The following types of structural opening are approved for Halspan FD30 doors:

- **Cast dense concrete**
- **Dense concrete blocks or brickwork**
- **Masonry**
- **Lightweight concrete**
- **Lightweight aerated concrete**
- **Timber stud partition**
- **Steel stud partition**

## HALSPAN FINISHES

### FINISHES

Halspan is particularly suitable for laminating & veneering. Whether fire door or not, Halspan is successful with veneer and clear lacquer, paint, plastic laminate.

The fine, hard surface minimises preparation time and together with its monolithic structure, these eliminate the problems like grin-through and ripple effect, found with other types of board.

### Veneer

Decorative or structural veneers up to 2mm in thickness can be applied to Halspan using the appropriate glue lines for the purpose. *N.B. A balanced construction must always be maintained.*

### HPL & PVC

High pressure laminate and PVC sheeting can be applied to Halspan up to 2 mm thickness using the appropriate glue for the purpose.

*N.B. A balanced construction must always be maintained.*

These facings can be retained on all door edges by post forming or other means, maintaining fire integrity. A maximum radius of 8mm may be used on postformed edges.

PVC protective edging can be applied maintaining the fire integrity with the use of the appropriate intumescent.

### Painting

Problems usually associated with other types of board are eliminated by using Halspan for example, it is not essential to add paper or veneer before painting.

With no preparation or only minimal attention, Halspan door blanks provide a suitable surface for a good paint finish, eliminating the usual problems associated with other types of board. Use products such as Becker Acroma, spray 2 coats of a high solid Acid Catalyst primer. (primer ref: DF 2011-9001). Alternatively, for brush or roller application a high solid water based primer ref: ED 2511-9001 is available (complies with The Environmental Protection Act 1990).

Both primer and finish may be applied direct onto Halspan. Sand between coats with 280 grit. (Finish applied by spray, at 100gm<sup>2</sup> per coat.)

### INTUMESCENT MATERIAL

The installation of fire doors and overpanels requires the use of intumescent strip, which may be fitted into the door leaf or frame.

However, if intumescents can be grooved into the frames, rather than the leaf, this will aid the leaf installation.

Both PVC encapsulated Palusol and graphite based products have been approved for use with Halspan.

Note that configuration changes may affect the size of intumescent strip used, e.g. door leaf size, doorset, frame, rebated edges, etc. Details and charts will be found in the relevant pages of this manual.

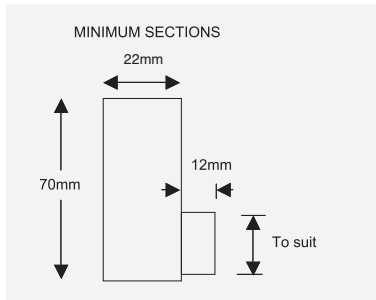

**HALSPAN FD30 FIRE DOOR FABRICATION & SPECIFICATION  
TIMBER & MDF FRAME SPECIFICATION**
**OPTIMA TIMBER FRAMES**

- Hardwood  $\geq 640\text{kg/m}^3$  density
- Single Action mode
- Door stop planted or wrought section

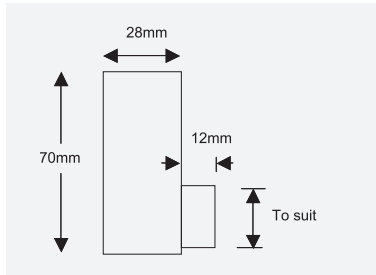

- Hardwood or Softwood  $\geq 450\text{kg/m}^3$  density
- Single Action mode
- Door stop planted or wrought section

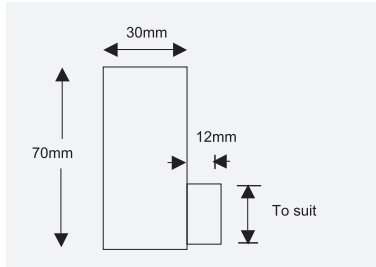

- MDF  $\geq 730\text{kg/m}^3$  density
- Single Action Mode
- Door stop planted or wrought section

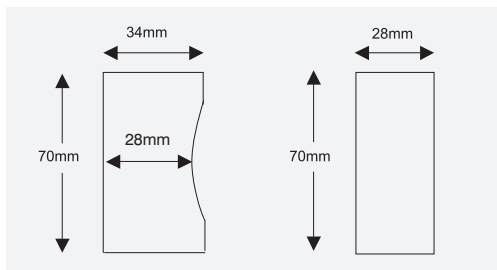

- Hardwood or Softwood  $\geq 450\text{kg/m}^3$  density
- Double Action Mode

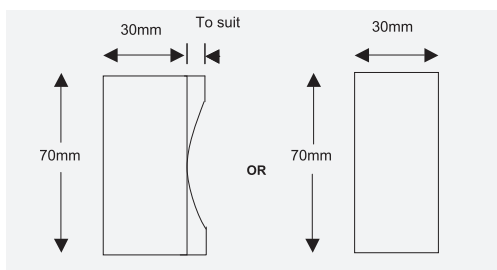

- MDF  $\geq 730\text{kg/m}^3$  density
- Double Action Mode

**HALSPAN FD30 FIRE DOOR FABRICATION & SPECIFICATION  
TIMBER & MDF FRAME SPECIFICATION**

**DOOR GAPS, MINIMUM LIPPING DETAILS SINGLE ACTION**

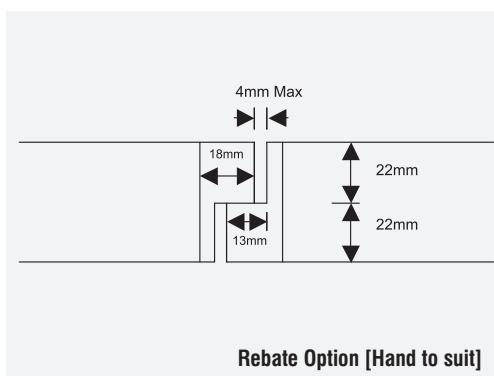
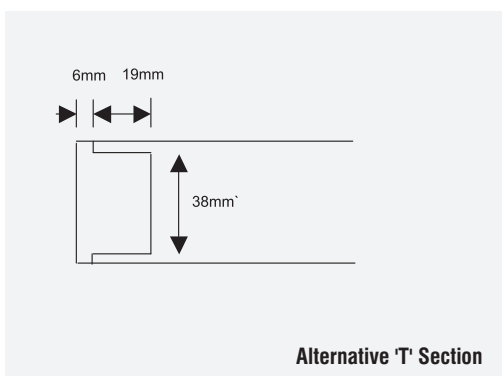
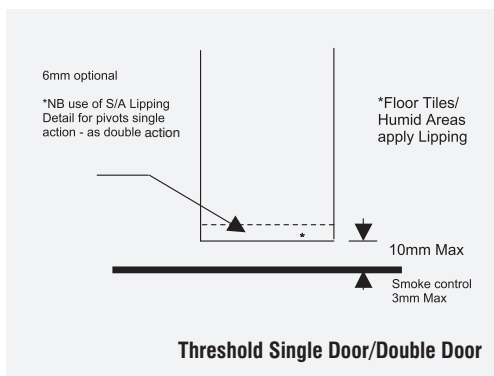
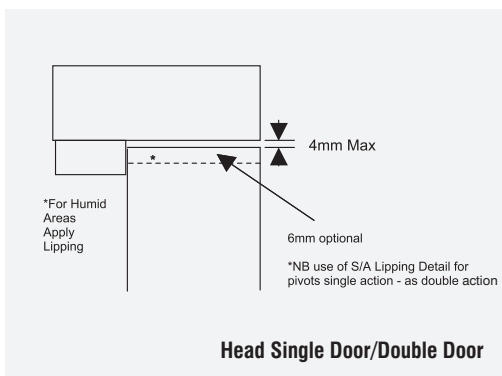
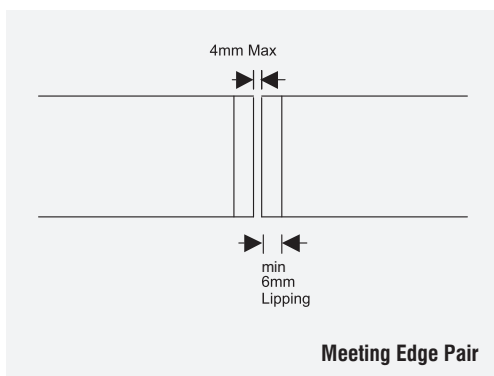
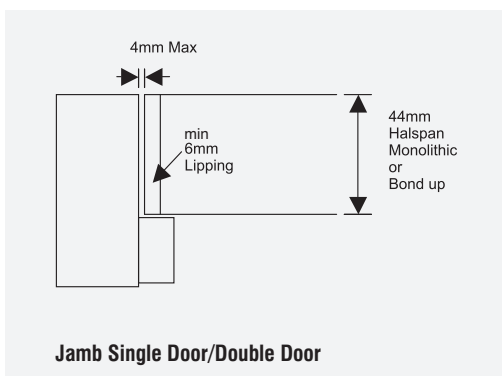

- Lipping Material- Hardwood  $\geq 530\text{kg/m}^3$  density @ 10% m/c  $\pm 2\%$
- Glue Line options- Urea Formaldehyde, Cascamite, PVA, PU, Hot Melt, PF
- See separate sections for intumecent detail



OPTIMA TIMBER FRAMES



**HALSPAN FD30 FIRE DOOR FABRICATION & SPECIFICATION  
TIMBER & MDF FRAME SPECIFICATION**

**DOOR GAPS, MINIMUM LIPPING DETAILS DOUBLE ACTION**

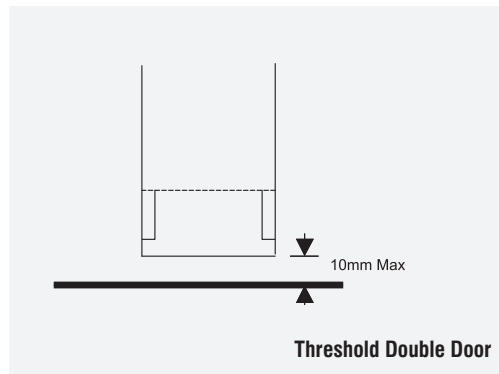
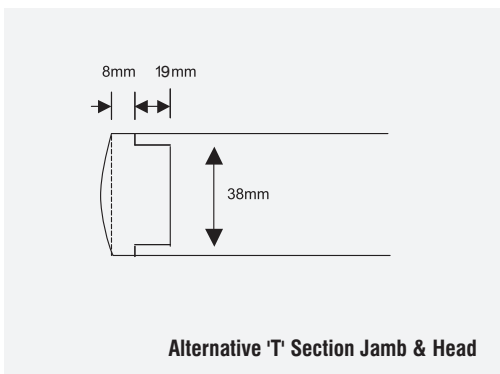
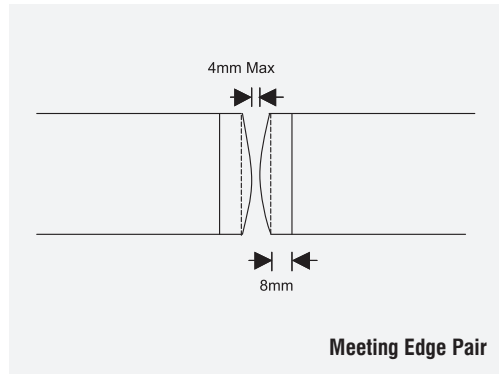
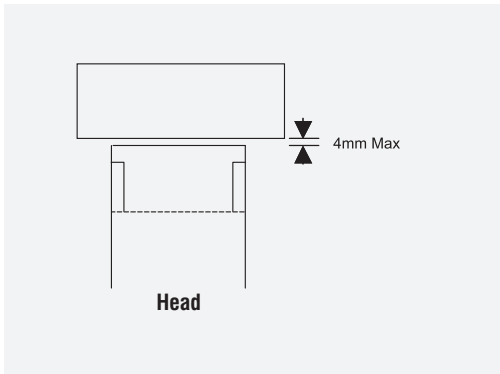
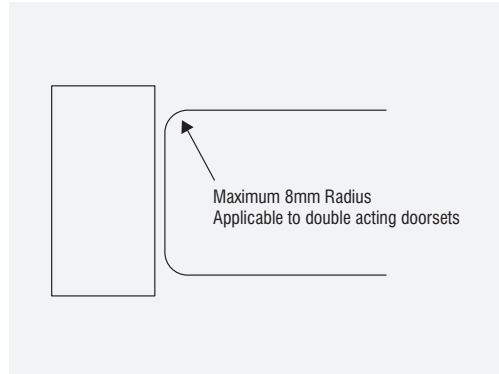
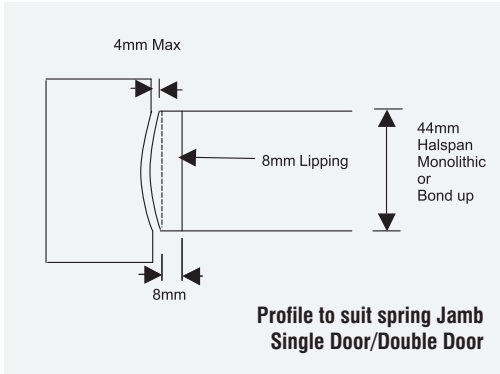

- Lipping Material- Hardwood  $\geq 530\text{kg/m}^3$  density @ 10% m/c  $\pm 2\%$
- Glue Line options- Urea Formaldehyde, Cascamite, PVA, PU, Hot Melt, PF
- See separate sections for intumescent detail

**\*Refer to notes in the ironmongery section – Floor Springs**

**HALSPAN FD30 FIRE DOOR FABRICATION & SPECIFICATION  
TIMBER & MDF FRAME SPECIFICATION**

**DOOR GAPS, MINIMUM LIPPING DETAIL INCLUDING  
OVERPANELS SINGLE AND DOUBLE ACTION**

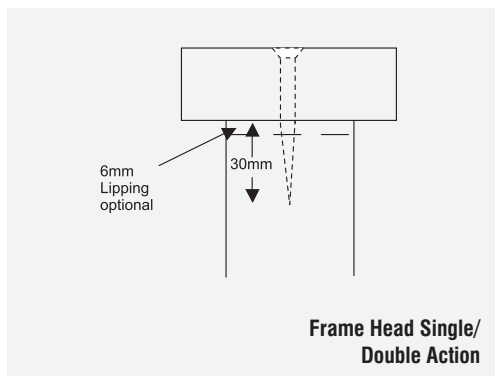
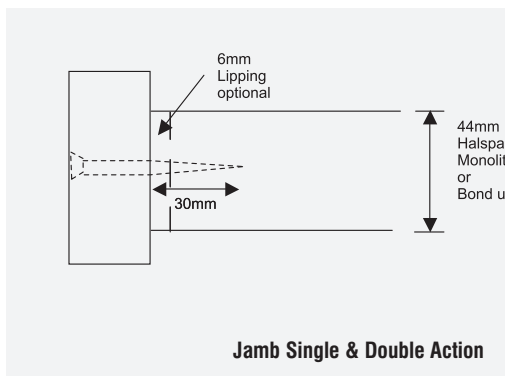

● Fixings = Steel, max 250mm centres, not < 100mm from corners of overpanel

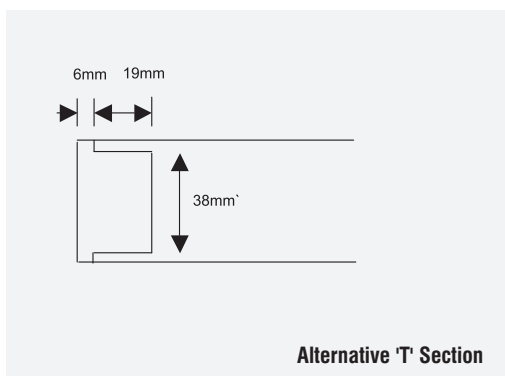
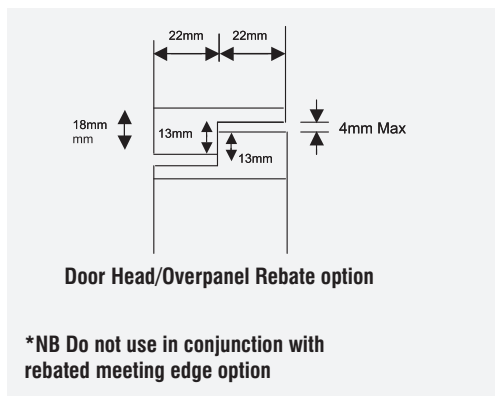
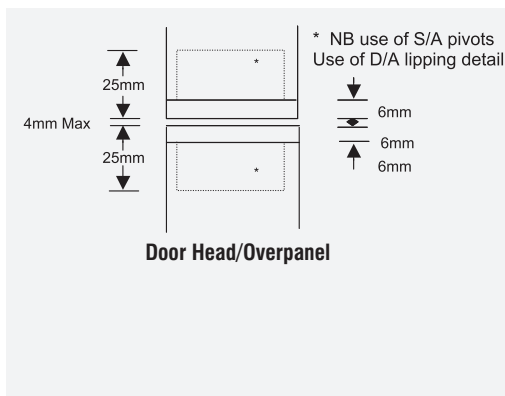

- Lipping Material- Hardwood  $\geq 530\text{kg/m}^3$  density @ 10% m/c  $\pm 2\%$
- Glue Line options- Urea Formaldahyde, Cascamite, PVA, PU, Hot Melt, PF
- See separate sections for intumecent detail

OPTIMA TIMBER FRAMES



**HALSPAN FD30 PERMITTED SIZES, CONFIGURATIONS  
INTUMESCENT SEAL DETAILS, TIMBER & MDF FRAME SPECIFICATION**

**LATCHED SINGLE ACTION SINGLE (LSASD)**

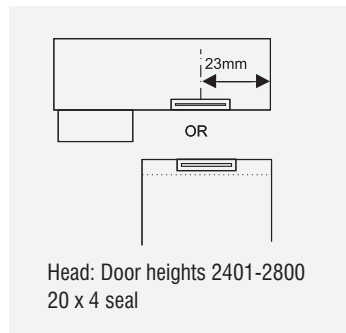
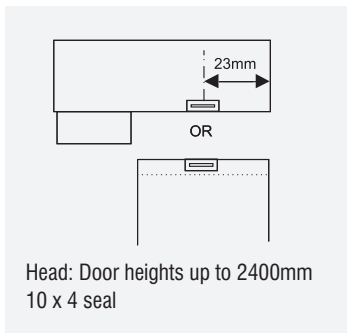
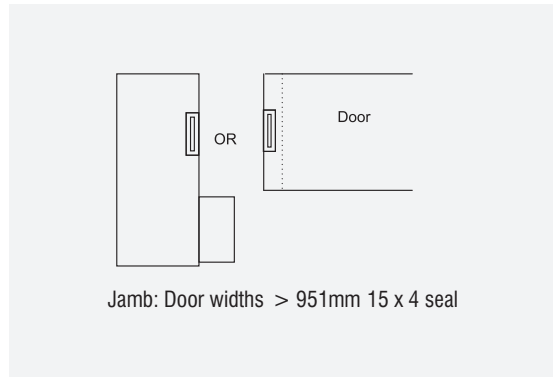
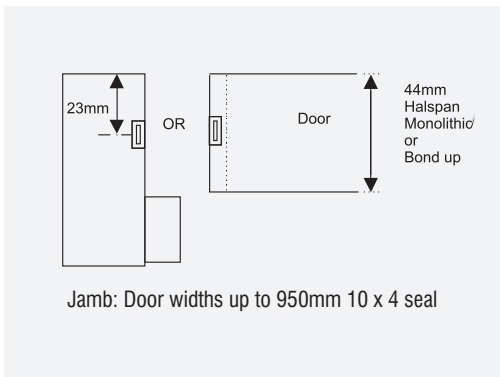
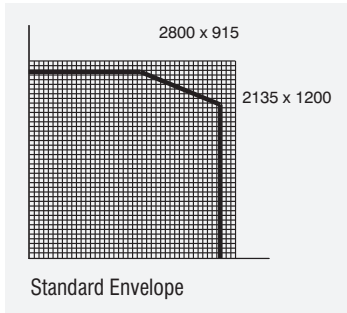

Approved Intumescents

- PVC Encapsulated Palusol (Lorient, Mann McGowan)
- Therm-A-Seal PVC Encapsulated graphite (Intumescent Seals Ltd)
- Reddiplex Group Pyroplex
- Halspan Intumescent Seals (SLS Range)

● **Smoke Control**

To achieve competent smoke control, the intumescent seals used in the jambs and head of fire doors should be replaced by a corresponding combined intumescent/smoke seal preferably fitted into the frame

Note: it may be necessary due to the required position of the intumescent seal to use additional smoke seals to maintain continuous protection past the hinge blades, lock strikes and top pivot assemblies - refer to seal manufacturer

## HALSPAN FD30 PERMITTED SIZES, CONFIGURATIONS INTUMESCENT SEAL DETAILS, TIMBER & MDF FRAME SPECIFICATION

### UNLATCHED SINGLE ACTION SINGLE (ULSASD)

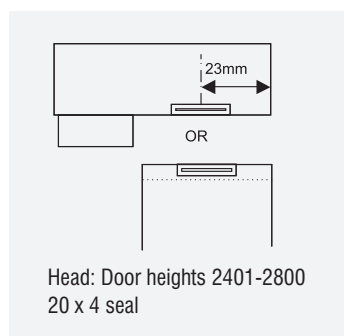
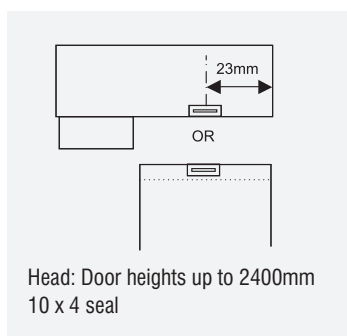
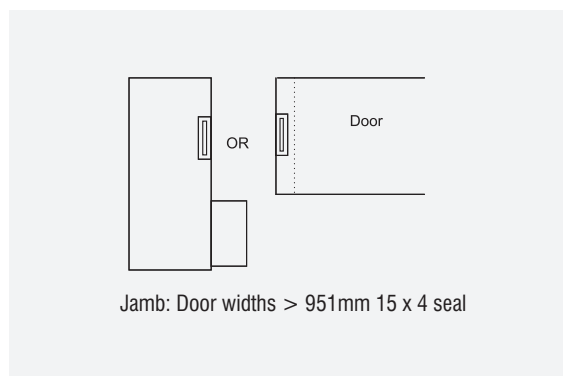
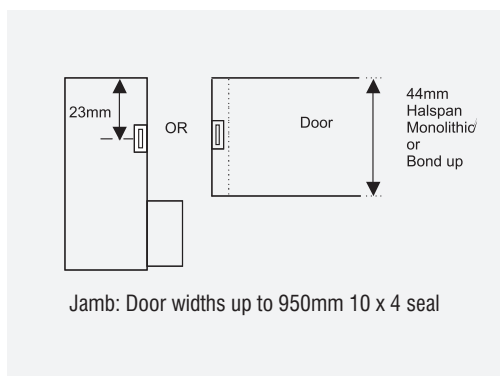
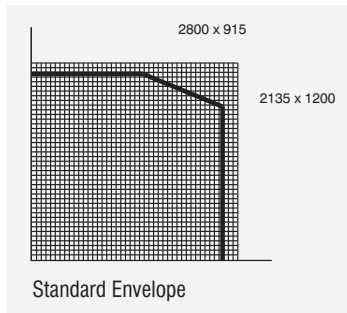

#### Approved Intumescents

- PVC Encapsulated Palusol (Lorient, Mann McGowan)
- Therm-A-Seal PVC Encapsulated graphite (Intumescent Seals Ltd)
- Reddiplex Group Pyroplex
- Halspan Intumescent Seals (SLS Range)

#### ● Smoke Control

To achieve competent smoke control, the intumescent seals used in the jambs and head of fire doors should be replaced by a corresponding combined intumescent/smoke seal preferably fitted into the frame

Note: it may be necessary due to the required position of the intumescent seal to use additional smoke seals to maintain continuous protection past the hinge blades, lock strikes and top pivot assemblies - refer to seal manufacturer

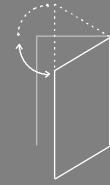

**HALSPAN FD30 PERMITTED SIZES, CONFIGURATIONS  
INTUMESCENT SEAL DETAILS, TIMBER & MDF FRAME SPECIFICATION**

**DOUBLE ACTION SINGLE (DASD)**

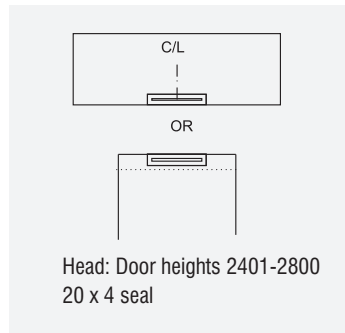
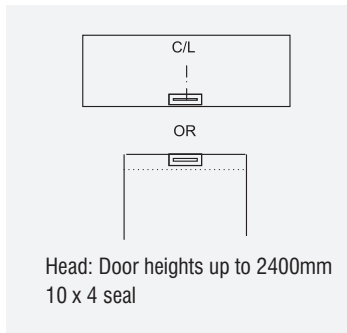
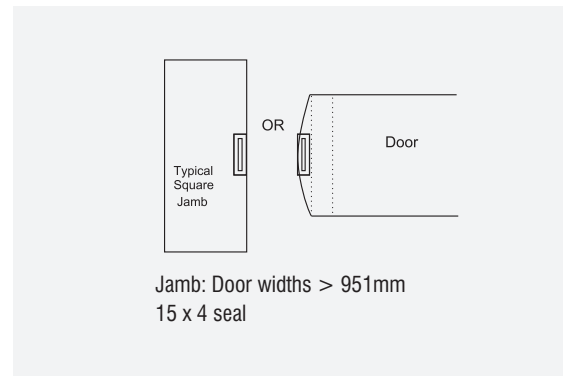
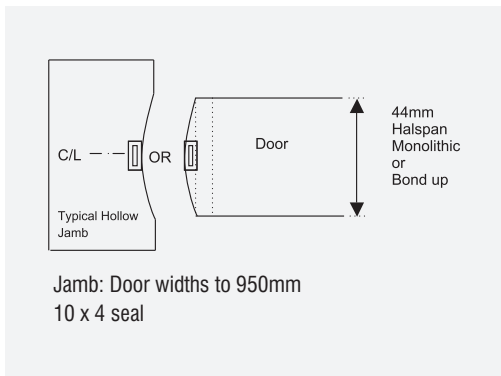
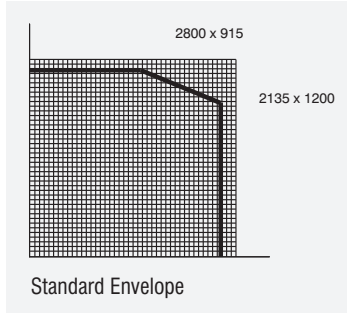

Approved Intumescents

- PVC Encapsulated Palusol (Lorient, Mann McGowan)
- Therm-A-Seal PVC Encapsulated graphite (Intumescent Seals Ltd)
- Reddiplex Group Pyroplex
- Halspan Intumescent Seals (SLS Range)

● **Smoke Control**

To achieve competent smoke control, the intumescent seals used in the jambs and head of fire doors should be replaced by a corresponding combined intumescent/smoke seal preferably fitted into the frame

Note: it may be necessary due to the required position of the intumescent seal to use additional smoke seals to maintain continuous protection past the hinge blades, lock strikes and top pivot assemblies - refer to seal manufacturer

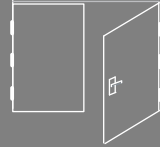

C2010

**HALSPAN FD30 PERMITTED SIZES, CONFIGURATIONS  
INTUMESCENT SEAL DETAILS, TIMBER & MDF FRAME SPECIFICATION  
LATCHED SINGLE ACTION DOUBLE (LSADD)**

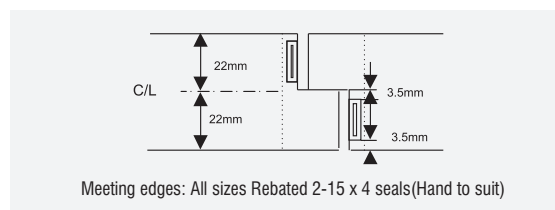
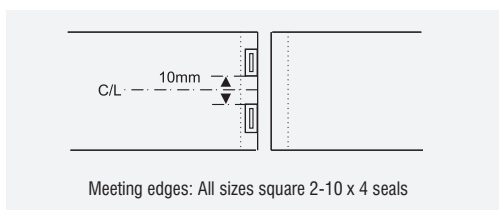
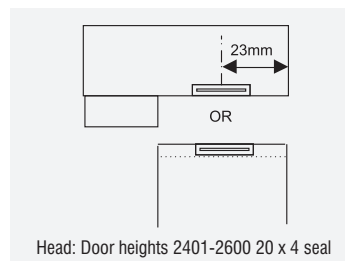
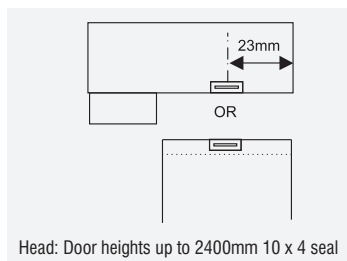
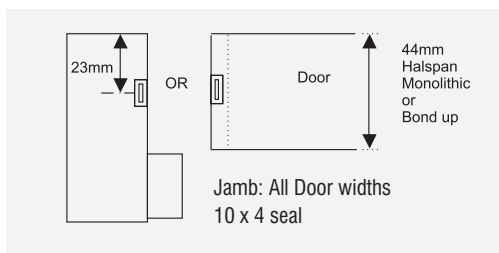
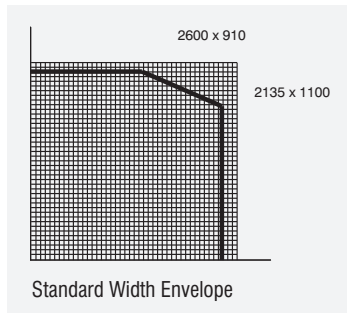

Approved Intumescents

- PVC Encapsulated Palusol (Lorient, Mann McGowan)
- Therm-A-Seal PVC Encapsulated graphite (Intumescent Seals Ltd)
- Reddiplex Group Pyroplex
- Halspan Intumescent Seals (SLS Range)

● **Smoke Control**

To achieve competent smoke control, the intumescent seals used in the jambs and head of fire doors should be replaced by a corresponding combined intumescent/smoke seal preferably fitted into the frame

Note: it may be necessary due to the required position of the intumescent seal to use additional smoke seals to maintain continuous protection past the hinge blades, lock strikes and top pivot

OPTIMA TIMBER FRAMES



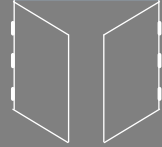

**HALSPAN FD30 PERMITTED SIZES, CONFIGURATIONS  
INTUMESCENT SEAL DETAILS, TIMBER & MDF FRAME SPECIFICATION  
UNLATCHED SINGLE ACTION DOUBLE (ULSADD)**

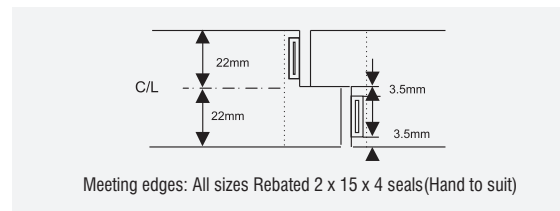
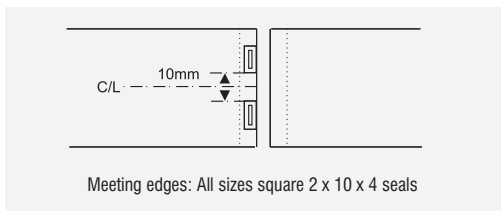
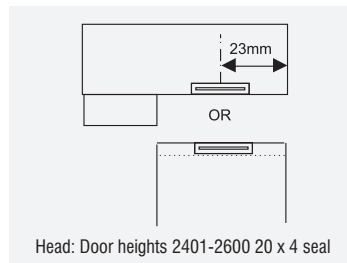
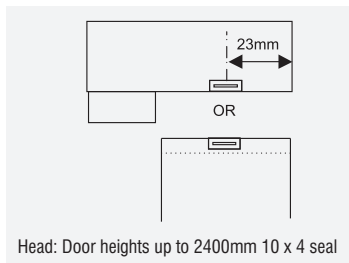
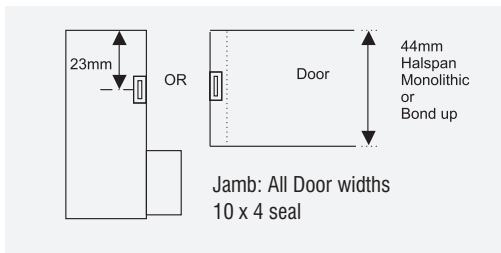
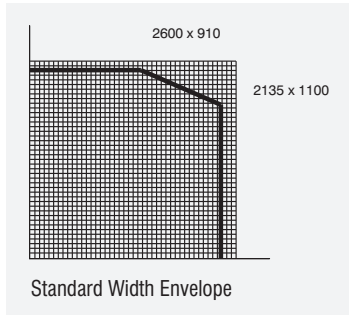

Approved Intumescents

- PVC Encapsulated Palusol (Lorient, Mann McGowan)
- Therm-A-Seal PVC Encapsulated graphite (Intumescent Seals Ltd)
- Reddiplex Group Pyroplex
- Halspan Intumescent Seals (SLS Range)

● **Smoke Control**

To achieve competent smoke control, the intumescent seals used in the jambs and head of fire doors should be replaced by a corresponding combined intumescent/smoke seal preferably fitted into the frame

Note: it may be necessary due to the required position of the intumescent seal to use additional smoke seals to maintain continuous protection past the hinge blades, lock strikes and top pivot

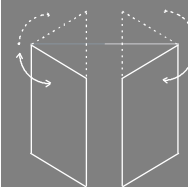

C2010

## HALSPAN FD30 PERMITTED SIZES, CONFIGURATIONS INTUMESCENT SEAL DETAILS, TIMBER & MDF FRAME SPECIFICATION

### DOUBLE ACTION DOUBLE (DADD)

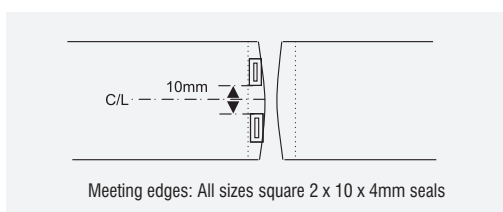
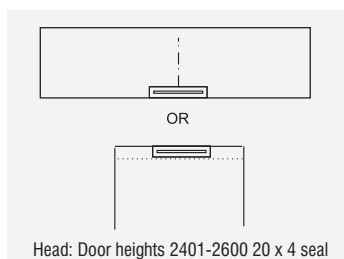
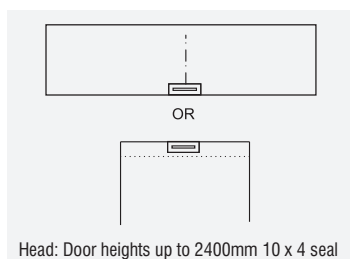
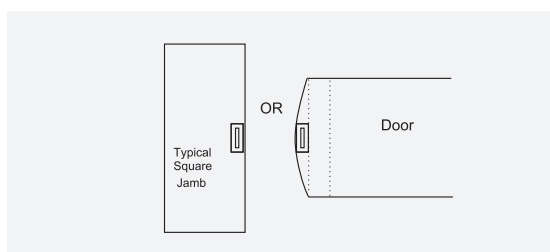
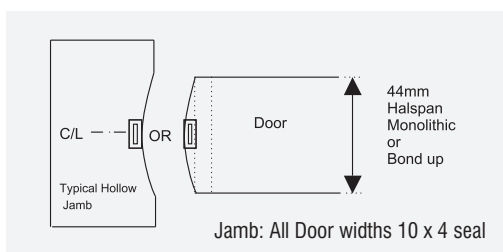
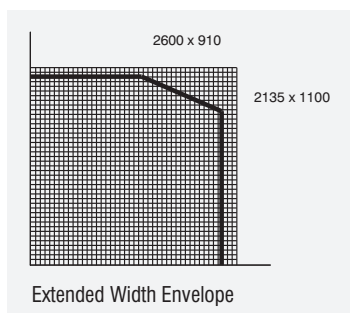

#### Approved Intumescents

- PVC Encapsulated Palusol (Lorient, Mann McGowan)
- Therm-A-Seal PVC Encapsulated graphite (Intumescent Seals Ltd)
- Reddiplex Group Pyroplex
- Halspan Intumescent Seals (SLS Range)

#### ● Smoke Control

To achieve competent smoke control, the intumescent seals used in the jambs and head of fire doors should be replaced by a corresponding combined intumescent/smoke seal preferably fitted into the frame

Note: it may be necessary due to the required position of the intumescent seal to use additional smoke seals to maintain continuous protection past the hinge blades, lock strikes and top pivot assemblies - refer to seal manufacturer

# OPTIMA TIMBER FRAMES



**HALSPAN FD30 PERMITTED SIZES, CONFIGURATIONS  
INTUMESCENT SEAL DETAILS, TIMBER & MDF FRMAE SPECIFICATION  
LATCHED SINGLE ACTION SINGLE & OVERPANEL (LSASD+OP)**

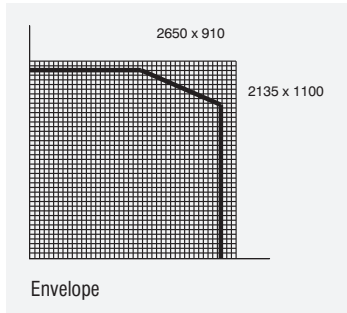

+Overpanel up to 2000 Max

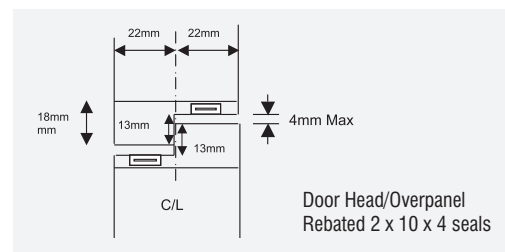
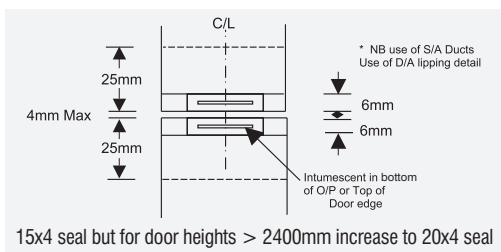
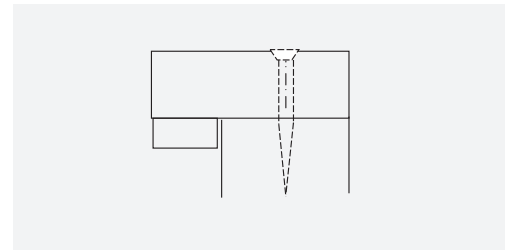
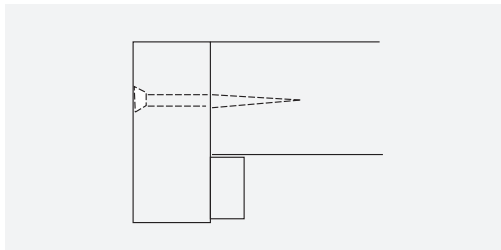
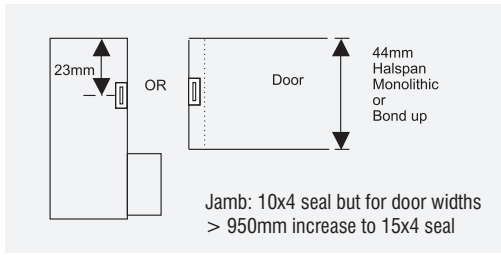

Approved Intumescents

- PVC Encapsulated Palusol (Lorient, Mann McGowan)
- Therm-A-Seal PVC Encapsulated graphite (Intumescent Seals Ltd)
- Reddiplex Group Pyroplex
- Halspan Intumescent Seals (SLS Range)

● **Smoke Control**

To achieve competent smoke control, the intumescent seals used in the jambs and head of fire doors should be replaced by a corresponding combined intumescent/smoke seal preferably fitted into the frame

Note: it may be necessary due to the required position of the intumescent seal to use additional smoke seals to maintain continuous protection past the hinge blades, lock strikes and top pivot assemblies - refer to seal manufacturer



C2010

**HALSPAN FD30 PERMITTED SIZES, CONFIGURATIONS  
INTUMESCENT SEAL DETAILS, TIMBER & MDF FRAME SPECIFICATION  
UNLATCHED SINGLE ACTION SINGLE & OVERPANEL (ULSASD+OP)**

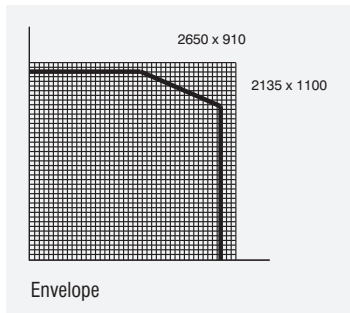

+Overpanel up to 2000 Max

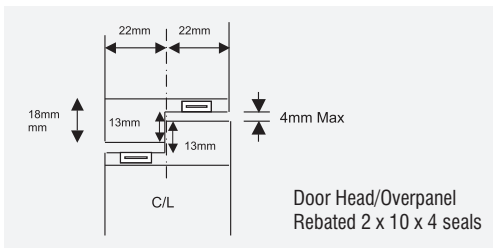
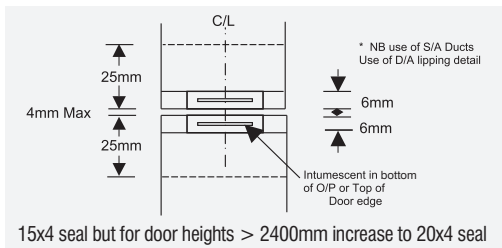
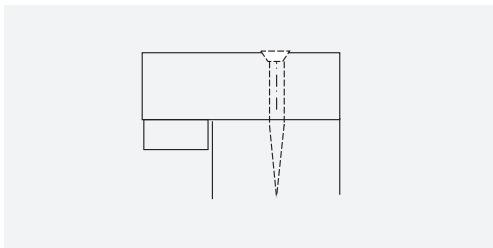
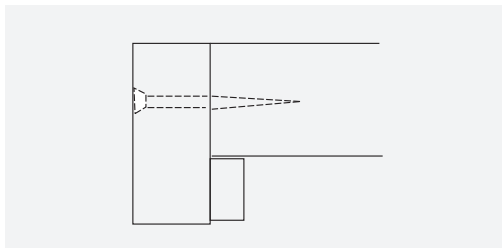
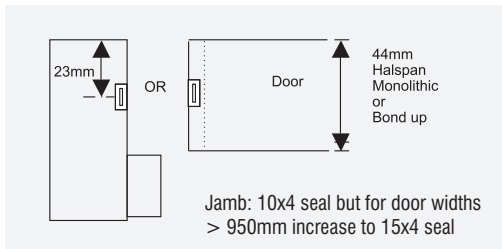

Approved Intumescents

- PVC Encapsulated Palusol (Lorient, Mann McGowan)
- Therm-A-Seal PVC Encapsulated graphite (Intumescent Seals Ltd)
- Reddiplex Group Pyroplex
- Halspan Intumescent Seals (SLS Range)

● **Smoke Control**

To achieve competent smoke control, the intumescent seals used in the jambs and head of fire doors should be replaced by a corresponding combined intumescent/smoke seal preferably fitted into the frame

Note: it may be necessary due to the required position of the intumescent seal to use additional smoke seals to maintain continuous protection past the hinge blades, lock strikes and top pivot assemblies - refer to seal manufacturer

OPTIMA TIMBER FRAMES

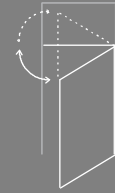

**HALSPAN FD30 PERMITTED SIZES, CONFIGURATIONS  
INTUMESCENT SEAL DETAILS, TIMBER & MDF FRAME SPECIFICATION  
DOUBLE ACTION SINGLE & OVERPANEL (DASD+OP)**

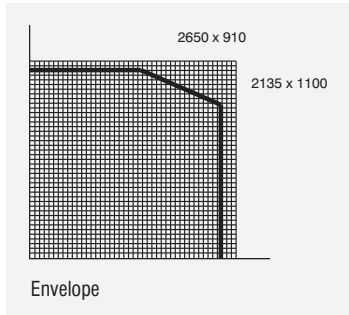

+Overpanel up to 2000 Max

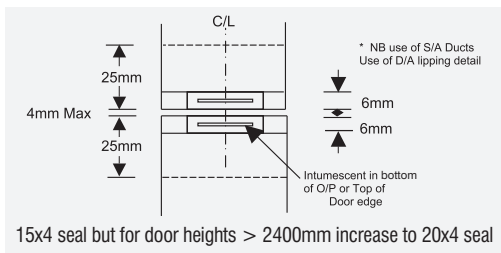
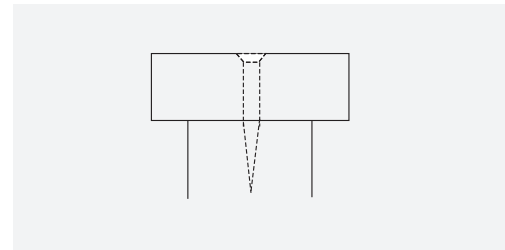
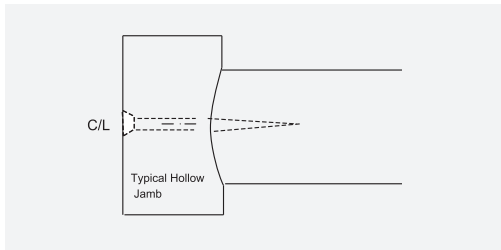
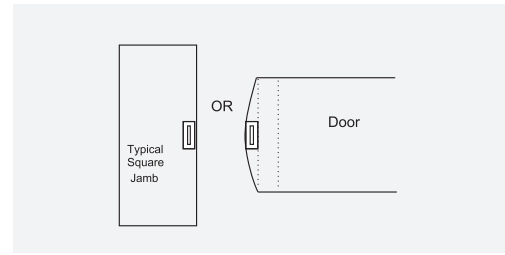
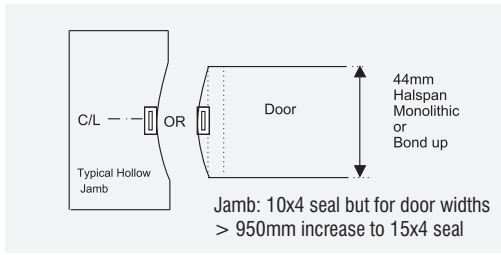

Approved Intumescents

- PVC Encapsulated Palusol (Lorient, Mann McGowan)
- Therm-A-Seal PVC Encapsulated graphite (Intumescent Seals Ltd)
- Reddiplex Group Pyroplex
- Halspan Intumescent Seals (SLS Range)

● **Smoke Control**

To achieve competent smoke control, the intumescent seals used in the jambs and head of fire doors should be replaced by a corresponding combined intumescent/smoke seal preferably fitted into the frame

Note: it may be necessary due to the required position of the intumescent seal to use additional smoke seals to maintain continuous protection past the hinge blades, lock strikes and top pivot assemblies - refer to seal manufacturer

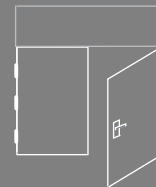

C2010

**HALSPAN FD30 PERMITTED SIZES, CONFIGURATIONS  
INTUMESCENT SEAL DETAILS, TIMBER & MDF FRAME SPECIFICATION**

**LATCHED SINGLE ACTION DOUBLE & OVERPANEL (LSADD+OP)**

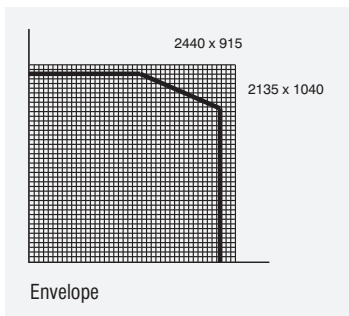

+Overpanel up to 1500 Max

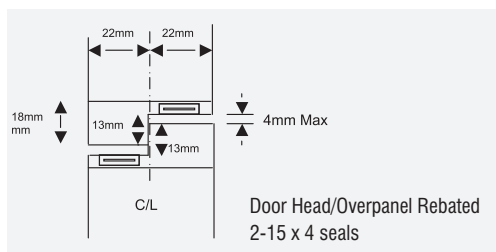
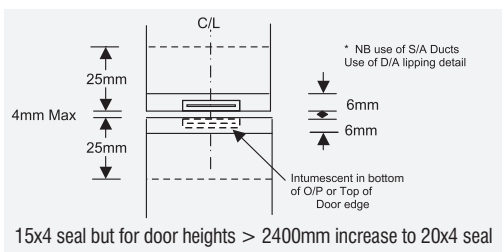
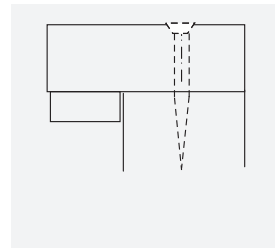
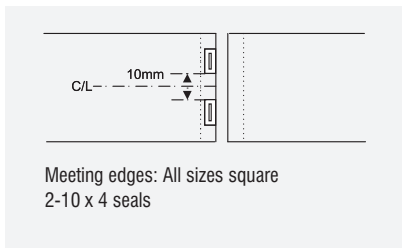
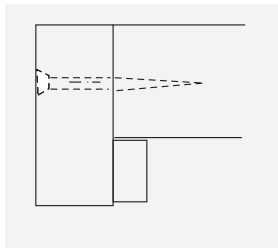
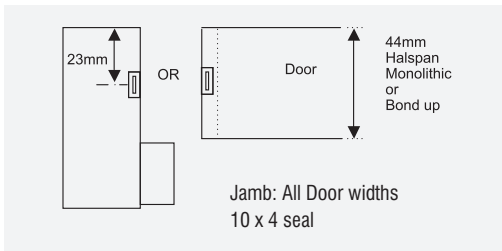

Approved Intumescents

- PVC Encapsulated Palusol (Lorient, Mann McGowan)
- Therm-A-Seal PVC Encapsulated graphite (Intumescent Seals Ltd)
- Reddiplex Group Pyroplex
- Halspan Intumescent Seals (SLS Range)

● **Smoke Control**

To achieve competent smoke control, the intumescent seals used in the jambs and head of fire doors should be replaced by a corresponding combined intumescent/smoke seal preferably fitted into the frame

Note: it may be necessary due to the required position of the intumescent seal to use additional smoke seals to maintain continuous protection past the hinge blades, lock strikes and top pivot assemblies - refer to seal manufacturer

OPTIMA TIMBER FRAMES

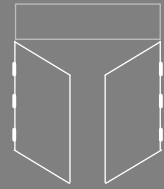

**HALSPAN FD30 PERMITTED SIZES, CONFIGURATIONS  
INTUMESCENT SEAL DETAILS, TIMBER & MDF FRAME SPECIFICATION  
UNLATCHED SINGLE ACTION DOUBLE & OVERPANEL (ULSADD+OP)**

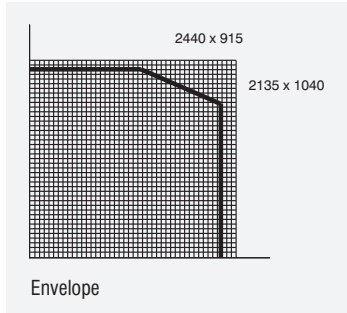

+Overpanel up to 1500 Max

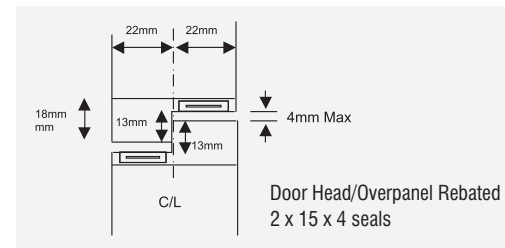
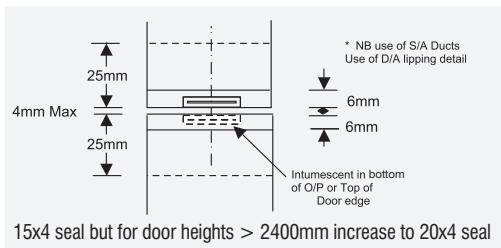
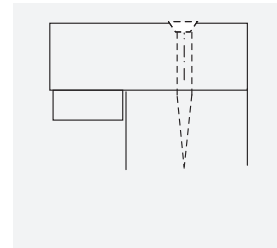
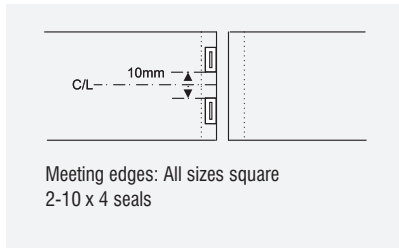
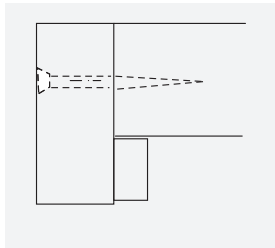
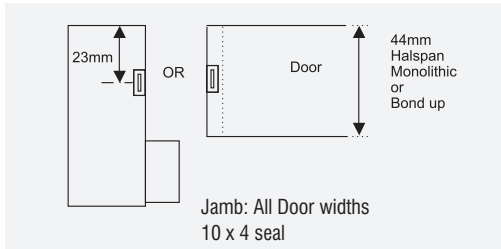

Approved Intumescents

- PVC Encapsulated Palusol (Lorient, Mann McGowan)
- Therm-A-Seal PVC Encapsulated graphite (Intumescent Seals Ltd)
- Reddiplex Group Pyroplex
- Halspan Intumescent Seals (SLS Range)

● **Smoke Control**

To achieve competent smoke control, the intumescent seals used in the jambs and head of fire doors should be replaced by a corresponding combined intumescent/smoke seal preferably fitted into the frame

Note: it may be necessary due to the required position of the intumescent seal to use additional smoke seals to maintain continuous protection past the hinge blades, lock strikes and top pivot assemblies - refer to seal manufacturer

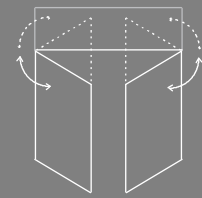

C2010

**HALSPAN FD30 PERMITTED SIZES, CONFIGURATIONS  
INTUMESCENT SEAL DETAILS, TIMBER & MDF FRAME SPECIFICATION  
DOUBLE ACTION DOUBLE DOORS & OVERPANEL - (DADD+OP)**

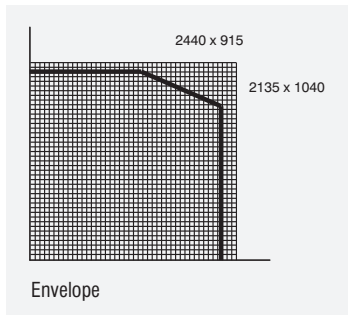

+Overpanel up to 1500 Max

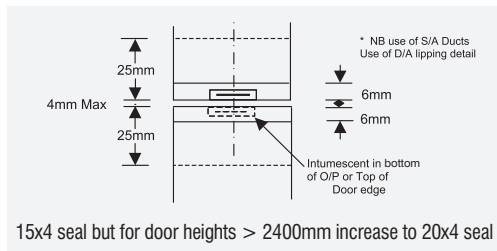
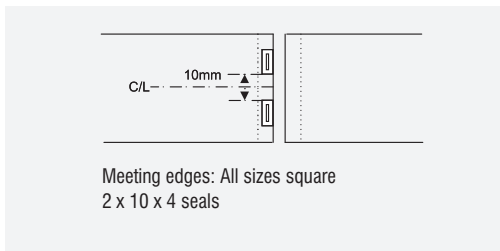
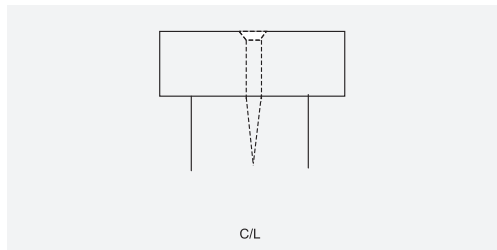
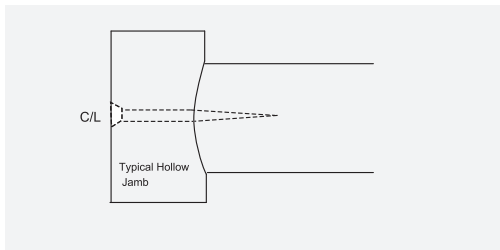
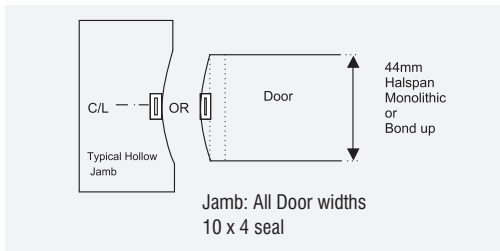

Approved Intumescents

- PVC Encapsulated Palusol (Lorient, Mann McGowan)
- Therm-A-Seal PVC Encapsulated graphite (Intumescent Seals Ltd)
- Reddiplex Group Pyroplex
- Halspan Intumescent Seals (SLS Range)

● **Smoke Control**

To achieve competent smoke control, the intumescent seals used in the jambs and head of fire doors should be replaced by a corresponding combined intumescent/smoke seal preferably fitted into the frame

Note: it may be necessary due to the required position of the intumescent seal to use additional smoke seals to maintain continuous protection past the hinge blades, lock strikes and top pivot assemblies - refer to seal manufacturer

OPTIMA TIMBER FRAMES



## HALSPAN FD30 FIRE DOORS IN ALUMINIUM FRAMES INTRODUCTION

Doors made from Halspan 44mm door blanks have been approved as fire doors conforming to BS476: Part 22:1987 for installation in aluminium framed FD30 doorsets.

### Fabrication

For general fabrication, door gaps and lipping details please refer to the relevant pages of this manual.

## ALUMINIUM DOOR FRAMES

### Material

Frames must be manufactured from extruding grade aluminium alloy 6063-16.

### Section

Minimum 100mm x 35mm (including integral architraves covering the partition or structural opening by 20mm) x 2mm thick. To include a 12mm deep stop.

### Frame Dimensions

Door frames must be of the wrap around type, enclosing the partition edge and the rear of the frame must be a contact fit with the structural opening.

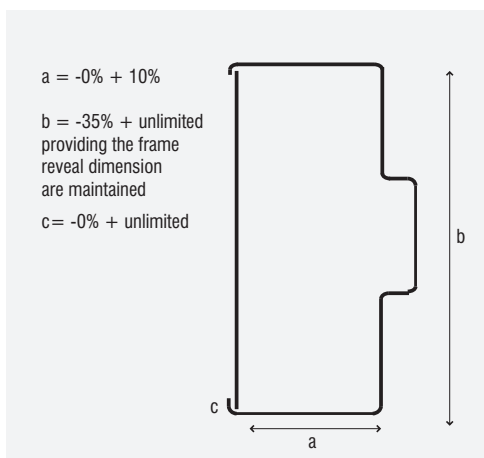

## INSTALLATION

### Structural openings

The following types of structural opening are approved for Halspan FD30 doors:

- Cast dense concrete
- Dense concrete blocks or brickwork
- Masonry
- Lightweight concrete
- Lightweight aerated concrete
- Timber stud partition
- Steel stud partition. (Partition apertures must be framed by steel studs, which have a minimum of 45 x 25mm softwood stiffeners to the vertical edges.)

### Gaps

Gaps between door frames and structural openings must be protected with proprietary materials that have been successfully tested for this application.

### Glazing

The details are contained within the glazing pages.

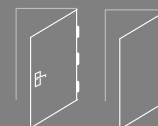

C2010

### HALSPAN FD30 PERMITTED SIZE CONFIGURATIONS OF ALUMINIUM FRAMES INTUMESCENT SEAL DETAILS

#### SINGLE DOORS

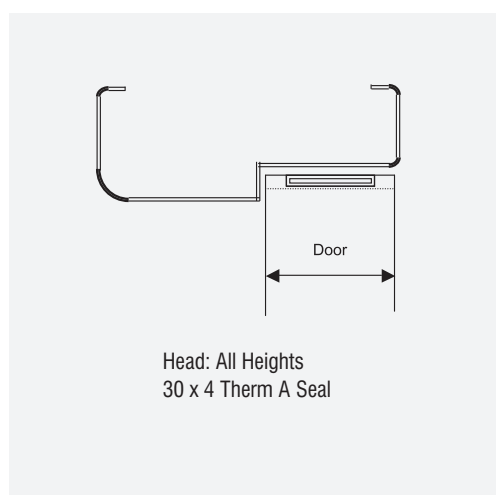
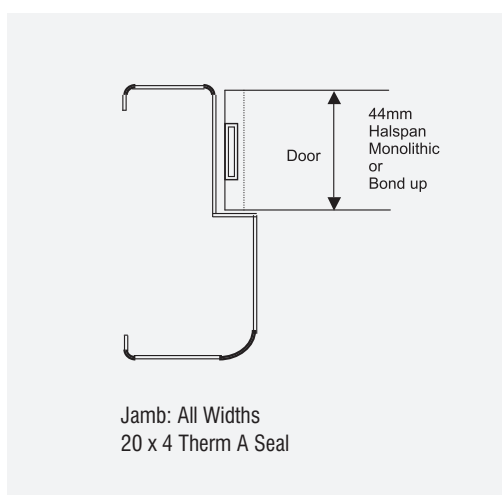
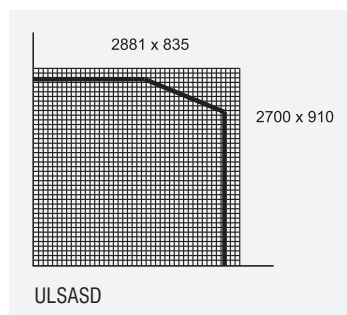
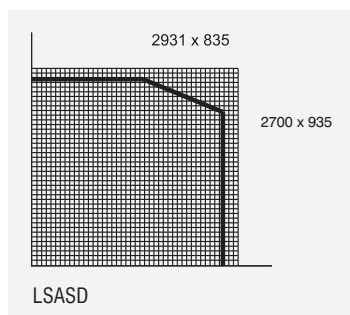

- For smoke control further provision should be made in the door edge.

**HALSPAN**<sup>®</sup>

C2010

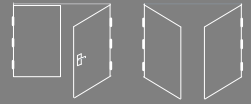

**OPTIMA ALUMINIUM FRAMES**

**HALSPAN FD30 PERMITTED SIZE CONFIGURATIONS OF ALUMINIUM FRAMES INTUMESCENT SEAL DETAILS**

**DOUBLE DOORS**

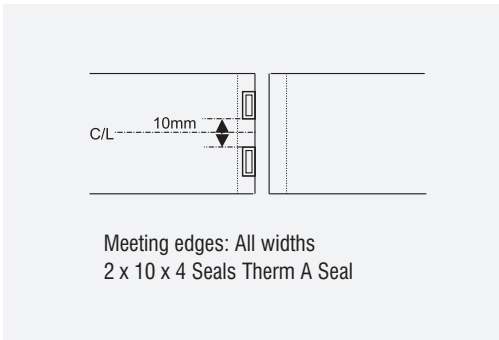
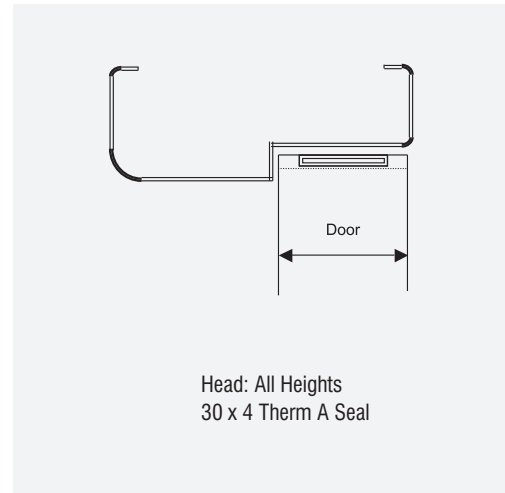
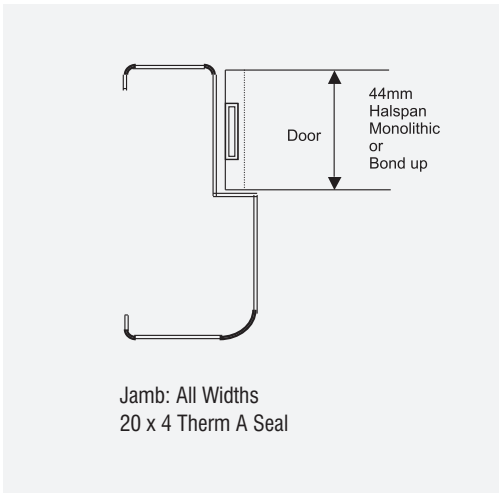
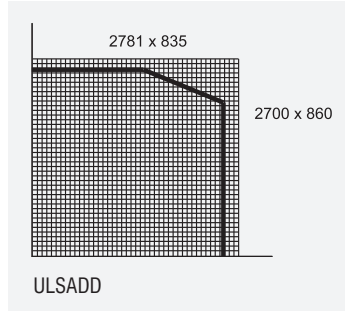
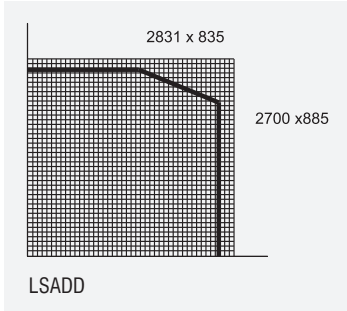

- For smoke control further provision should be made in the door edge.



Halspan Optima doors in full doorset mode (nominal 2100mm x 900mm, unglazed) have been tested in single action single and double action single mode and achieved **Severe Duty grading**.

## BS MECHANICAL TESTS

### Mechanical Tests: Procedure

The tests were conducted in accordance with the British Standard Draft for Development DD171: 1987: "Guide to specifying performance requirements for hinged or pivoted doors (including test methods)".

A brief description of the mechanical tests carried out is presented in Table 1. The British Draft Standard gradings are defined as follows:

#### LD-Light Duty

Low frequency of use by those with a high incentive to exercise care, e.g. by private house owners – small chance of accident occurring or of misuse.

#### MD-Medium Duty

Medium frequency of use primarily by those with some incentive to exercise care – some chance of accident occurring or of misuse.

#### HD-Heavy Duty

High frequency of use by public and others with little incentive to exercise care. Chance of accident occurring and of mis-use.

#### SD-Severe Duty

Subject to frequent violent usage.

**Table 1 Summary of Test Methods**

Test	Grade	Summary of Test Method	Measurement
Hard body impact	LD	50mm diameter solid steel ball impacting door at 15 points with 2Nm)	Deformation
	MD	3Nm)	
	HD	5Nm)	
	SD	8Nm) Impact Energy	
Operation	All	Horizontal push applied to door leaf	Force required to open and close door
Torsion	All	400N applied horizontally at mid height of lockside edge of open door with top lockside edge restrained	Deformation
Downward Deformation	All	500N applied vertically at mid height of lockside edge of open door	Damage Check
Closure against obstruction	All	Closing force of 200N applied to door with 10mm thick hardwood slip between bottom hinge side edge and frame	Damage Check
Slamming Shut	LD	10) Slams shut from a 60 degree	Damage Check
	MD	20) open position caused by	
	HD	100) the action of a falling	
	SD	150) 15kg mass	
Slamming Open	LD	10 slams from a 30 degree (5Nm)	Damage Check
	MD	Closed position with (25Nm)	
	HD	impact energy (50Nm)	
	SD	(50Nm)	
Abuse	All	750N direct pull on handle in Opening direction with door in position	Damage Check
Jarring	LD	50) impacts of 75N on the	Damage Check
	MD	100) unrestrained closing	
	HD	150) face at a 45 degree open	
	SD	200) position	
Heavy Body Impact		3 impacts on each face of the closed Door with impact energy of	Damage Check
	LD	20Nm	
	MD	40Nm	
	HD	100Nm	
	SD	150Nm	



## ACOUSTIC PERFORMANCE

Doorsets within buildings form part of their internal fabric and as such may often be required to offer noise reduction performance, or sound attenuation. The acoustic performance of a doorset design can be established in laboratory tests to BS EN ISO 140-3 1995 (formally BS2750pt 3 1980). Airborne sound transmission is determined from the difference in sound pressure levels measured across a test sample (doorset) installed between two reverberant rooms (SRL 2003). The 'transmitting room' and 'receiving' rooms are calibrated such that the sound signals are filtered into 1/3 octave bands, integrated and averaged. The difference in values between the two rooms will give an average reduction value of performance across the frequency range. The Sound Reduction Index (R) is also known by the American terminology Sound Transmission Class (STC) and is defined as the number of decibels by which sound energy randomly incident on the test sample, is reduced in transmitting through it. (SRL 2003).

These laboratory figures give an average value of sound attenuation over the 100Hz to 3150Hz frequency range, but cannot give a snapshot view of performance in the evaluation of the acoustic performance of products in buildings. So, to produce a value which more reflects human hearing and perception the figures are correlated to a standard reference curve with a single value output. The methodology for this process is defined in BS EN ISO 717-1 : 1997 (formally BS 5821 : 1984). The output is described as the Weighted Sound Reduction Index (Rw).

## LABORATORY RESULTS VERSUS SITE PERFORMANCE

As in fire situations, the tested door set up is rarely replicated on site. Therefore, if there is a measurement of sound reduction on site, the results will depend on a number of factors – volume and occupancy of transmitting room, volume and occupancy of receiving room, area of wall/partition, performance of wall/partition, accuracy of installation of doorset, floor and wall finishes etc... Inevitably, in practise, the potential sound reduction of a doorset is never achieved on site.

## HALSPAN AND ACOUSTIC PERFORMANCE

Halspan has been extensively tested using various perimeter sealing options in single and double door configurations and also including glazing. The laboratory testing methodology described has been employed.

Please refer to the Halspan Acoustic Manual for specifications and sealing options for the various configurations that have been approved.

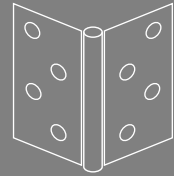

C2010

## IRONMONGERY

### HINGES

Careful selection of hinges is one more important part in ensuring that fire resistance will be maintained. Do not overlook the weight aspect, as hinges chosen **must be suitable for the weight of the door including ironmongery.**

#### Hinge Types

Fixed pin, washered butt ball bearing butt or journal supported lift off hinges. When using Halspan, hinges should conform to PREN1935 (BS7352:1990)

Hinges must be suitable for the weight of the door leaf plus its associated ironmongery.

#### Not suitable

Rising butt, invisible, non-cranked butts and spring hinges (single or double action) are not permitted, unless fire test/assessment evidence is available to justify their performance.

#### Hinge Materials

Brass (to BS2874); phosphor bronze; steel, stainless steel. (Aluminium, nylon or Mazac are not permitted.)

No combustible or thermally softening materials to be included.

#### Number of Hinges

3 No (1½ pairs) per leaf; if greater than 2300mm high, 4 No per leaf.

#### Positions

Set top of hinge 150mm - 200mm from top of door leaf. Bottom of bottom hinge 150mm - 200mm up from bottom of door leaf.

#### For 3 No hinges

Mid hinge may be either centrally in leaf height or, set 200mm below top hinge.

#### For 4 No hinges

Fit two hinges equally spaced between top and bottom hinges.

#### Fixings

Steel screws, as recommended by the hinge manufacturers, but in no case smaller than No 10 x 32mm long, and having thread for the full length with parallel shank. For satisfactory fixing, the use of Twinfast type screws is recommended. For severe duty use No 10 x 44mm long screws.

#### Hinge Leaf Sizes

These dimensions denote the amount by which hinges are let into the leaves: 3.5mm thick (max) x 90-120mm high x 30-35mm wide.

# IRONMONGERY

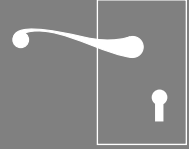

## LATCHES/LOCKS

When using Halspan, locks and latches should conform to PREN12209 (BS5872: 1980) and should comply with the following specifications.

### Mortice latches, tubular mortice latches.

#### Maximum dimensions

Forend + Strike 235mm high x 32mm wide x 6mm thick

Latch Body 165mm high x 100mm wide x 25mm thick

*Latches must have no essential part of their structure made from polymeric or other low melting point (<800°C) materials.*

The above does not exclude latches that have dimensions and/or specification not in accordance with those described above, provided they have been successfully fire resistance tested. Any items which do have applicable fire resistance test or assessment evidence can be used.

#### **Fitting**

Where latches are fitted, they should be centred at 1000mm ( $\pm$  100mm) from the bottom of the leaf.

Where fitting latches to Halspan doors, it is important that their size shape and position in the leaf does not compromise its integrity, either by weakening the leaf structure or by causing burn-through.

## Intumescent Seals

At meeting stiles of pairs or any lock fitted with a forend which exceeds 150mm in height the strike and forend must be protected with 1mm thick interdens, Halspan intumescent lock protection (ref: SLS-PAD) or or 2mm thick Thermastrip.

Over-morticing is to be avoided. Mortices should be as tight as possible to the latch.

Holes for spindles should be kept as small as is compatible with the operation of the ironmongery.



## DOOR CLOSERS

When using Halspan, door closers should be either floor springs, approved concealed closers or surface mounted closers and, for proven performance and mechanical durability, should conform to BS6459:Part 1. Other forms of door closers may be used, providing supporting fire test/assessment evidence is available to justify their use.

All fire rated door leaves to be fitted with a door closer must be specified with due consideration of the leaf width/weight.

### 1. Face-fixed Overhead Door Closers

Face-fixed overhead door closers and accessories (such as soffit brackets) that have been tested, assessed or otherwise approved for use on unlatched FD30 timber door leaves in timber frames may be used.

Any accessory which is located within the door reveal must have appropriate test or assessment evidence.

Closers used in tests were Dorma TS73, but other closers used must comply with the above specifications. 'Certifire' approved closers with the code ITT30 (or higher) as appropriate may also be used on these doorsets.

It is essential that the closers are of the correct power rating for the width and weight of the doorsets and are fitted accordingly to the manufacturers instructions. They must be capable of fully closing the door leaf and engaging the latch from any position.

### 2. Concealed Overhead Door Closers

The use of Dorma ITS96 concealed overhead closers are approved. These are side arm type closers with the closer morticed into the head of the leaf, and a single arm and roller acting in a slide channel morticed into the frame head.

The closer is installed in a 260mm long x 60mm deep mortice in the door head, with the slide channel in a 25mm wide x 19mm deep x 540mm long mortice in the frame head. The slide arm channel and the closer body must be installed with the intumescent gasket kit supplied with the closer.

We recommend Halspan be a minimum of 50mm thickness (or 54mm Optima) to accommodate the

closer. These closers have been tested by Dorma and, subject to the limitations given below, Dorma ITS96 concealed closers may be used on latched or unlatched single and double leaves without overpanels.

#### Limitations

- 1) Minimum stop depth of 25mm on frame head required.
- 2) Include intumescent gasket kit as tested and supplied by Dorma.
- 3) In doors with glass openings, when using the ITS96 closer, the top margin between door head and aperture must be 175mm minimum.
- 4) The top edge of the door must include a 20mm lipping to maintain 8mm of timber continuous under the arm recess.
- 5) An additional 10mm x 2mm strip of graphite intumescent must be included in the arm recess in the head of the door.

#### Mitron Concealed Door Closer

The Mitron C2300 series door closer is a single action reversible fully concealed door closer with hydraulic check action and rack & pinion mechanism. This model may also be mounted on the surface of the door with optional cover plates.

#### Sizes

C2303 Medium for doors up to 950mm wide. C2302 Light for non-fire rated doors up to 850mm wide.

Hold open device is supplied as standard. This must not be used on fire doors.

#### Intumescent

For all fire doors, these closers must be fitted with the optional adhesive Intumescent Pack. This is easily applied to the door closer before fitting.

#### Fixing

A minimum top rail depth of 120mm is required. Detailed fixing instructions are supplied with each closer.

#### NB

- **Concealed closers are not approved in overpanel configurations.**
- **Doorstops to head should be increased to 25mm in depth.**



## BOLTS

### Limitations

#### Face Fixed Door Bolts

Face fixed door bolts may be made from any non-combustible material and shall not incorporate any combustible components.

#### Edge Mounted flush bolts

The size of edge mounted flush bolts shall not exceed 200mm long x 34mm wide x 20mm deep.

#### Steel or Brass Faced Mounted Bolts

Where they are made of steel, stainless steel or brass, the length of face mounted bolts shall not exceed 400mm length, with no limit on width. They should be fixed with a minimum 60mm between bolt and door edge. The recess for flush bolts must not exceed 15mm depth.

Screws for fixing bolts must be at least 25mm long, threaded full length.

### Invalid Bolt Materials

Bolts made from materials with a melting point lower than 850°C are not acceptable.

### Intumescent Protection

#### Face Mounted Flush Bolts

Not required.

#### Edge Fixed Flush Bolts

Where the bolt causes interruption in the intumescent seals in the door meeting edge/stile, the recess for the bolt must be lined with minimum 1mm thickness of intumescent mastic or sheet material; plus intumescent seal maintained adjacent to the bolt, minimum 5mm width to at least one side of the flush bolt.

#### Seals Interruption

Additional protection for bolts causing interruption in the door or frame seal at the leaf head (e.g. edge fixed flush bolts) must be provided by manufacturer.

## FLOOR SPRINGS

Floor springs and accessories (straps and pivots) are necessary for single and double acting assemblies. They require the appropriate test or assessment evidence for use on timber door assemblies. Refer to lipping recommendations, contained in this manual.

The floor springs selected must also be matched against the weight of the door on which they are to be fitted.

### Intumescent Seals

Use the manufacturer's intumescent gasket set provided and follow the instructions.

- I) Continuation of at least 5mm width of the intumescent edge seals in leaf or frame head (as applicable) along both sides of the top strap/pivot.
- II) If intumescent edge seals are in the door frame, then 2mm thick intumescent sheet must also be included to the sides of the mortice, for top and bottom straps in the door.
- III) No removal of the timber or intumescent at the vertical leaf edge/stile must occur.

**\*Care must be taken when fitting bottom straps and top centres. Inaccurate morticing and incorrect adjustment of the spring and closing force of the unit will lead to problems in service.**

**Refer to hinge section for fixing recommendations.**

## NON ESSENTIAL IRONMONGERY

### Pull Handles

These may be surface-fixed to the door leaf provided that they are steel or aluminium, and that their length is limited to 1065mm between the extreme fixing points. No additional intumescent protection is required provided that the hole for the bolt through the leaf is tight, unless test evidence dictates otherwise.

### Push Plates/Kick Plates

Face-fixed ironmongery such as push plates and kick plates may be fitted to the doorsets provided that they are recessed by no more than 2mm. These items of ironmongery must not amount to more than 20% of the door leaf area.

### Door Selectors

These may be freely applied, provided that they are not invasive in the leaf edges or door frames. Those that are invasive will require fire resistance test/assessment evidence to support their use.

No additional intumescent protection is required unless test evidence dictates otherwise.

### Door Security Viewers

Door security viewers with brass or steel bodies of a diameter less than or equal to 25mm may be used provided that the through-hole is bored tight to the case of the viewer (maximum tolerance +1mm). Both glass and plastic lenses are acceptable. No additional intumescent protection is required unless specific test evidence in comparable doorsets dictates otherwise.

### Panic Ironmongery

Panic ironmongery may be fitted, provided that its installation does not require the removal of any timber from the leaf, stop, or frame reveal and it in no way interferes with the self-closing action of the door leaf.

### Cable-Way

Given the reported integrity performance of the doorset construction, with no burn through of the core material, we consider it acceptable to allow the provision for a concealed 'cable-way' for electro-magnetic closing/latching mechanisms (providing that they have suitable test evidence to support their use on this type of 30 minute doorset construction). The 'cable-way' may be concealed in one of the following ways.

- A 10mm (maximum) diameter hole centrally drilled in the core material extending straight across the width of the leaf (not diagonally).
- A central 10mm x 10mm groove rebated into the edges of the core with the base of the groove lined with 10mm wide x 2mm thick Interdens gasket. The lipping must be glued over the top of the wire-way.

### Letter Boxes/Plates

Letter Boxes/Plates are acceptable provided that they have direct test evidence to BS 476: Part22: 1987 that demonstrates their suitable integrity performance (minimum 30 minutes) when installed within a timber based doorset of comparable thickness. Margins to the leaf edges will remain as referenced for glazing. The position of the letter box/plate will be dictated by the pressure regime tested in the proving evidence.



### Air transfer Grilles

The tested specimens proved to have no adverse effects on the surrounding door leaf and as such grilles of the same type may be installed within the assessed door leaf construction, subject to the following provisos:

- The ventilation grille must be the same as that tested i.e. Lorient LV40, with the associated mild steel grille screw fixed to each face of the leaf;
- The ventilation grille must not be positioned closer than 100mm from any leaf edge;
- The ventilation grille must be positioned with its top edge below 1000mm from the bottom of the door leaf;
- Installation of the ventilation grille (including all relevant intumescent details) must be as tested;
- The air transfer grille must not be installed within the 'thinned' section of door leaf;

- The grille area must not exceed that tested i.e. 0.20m<sup>2</sup>, and no linear dimension (height or width) must exceed 600mm;
- Multiple grilles are acceptable with minimum separation as shown for the glazing.

Given that the air transfer grilles will require the removal of a section of door leaf, the area of the grille must be deducted from the maximum area of glazing that is currently assessed.

### Example

The maximum assessed amount of glass is currently 1.29m<sup>2</sup>.

If a 450mm x 450mm grille is to be used (0.20m<sup>2</sup>) then the maximum amount of glass that would be acceptable will be:

$$1.29\text{m}^2 - 0.20\text{m}^2 = 1.09\text{m}^2$$

## HALSPAN FD30 GLAZING

### INTRODUCTION

Halspan is capable of tolerating relatively large glazed apertures. Tests and approval cover a variety of aperture shapes.

#### Maximum area of glazing.

Aperture sizes up to a maximum combined area of **1.29m<sup>2</sup>/leaf**.

Examples of design styles, including square, rectangle, circular and multi-pane, will be found in this section.

### Construction

Cut aperture directly into Halspan, with beads fitted directly to the particle board.

### Lipping

Where necessary, fit lipping to edges of the cut-out prior to installing the glazing system. Fit 10mm thick hardwood lipping > 530kg m<sup>3</sup> density, at a moisture content 10±2%.

### Adhesives

Bond with Polyurethane (PU), PVAC or Urea Formaldehyde, Hot Melt.

### Beads

Glazing beads must be hardwood > 640 kg m<sup>3</sup> density at moisture content 10 + 2% and must be either pinned or screwed in position using steel fixings in accordance with the glazing system manufacturer's requirements in order to maintain the integrity of the fire door.

### Glass Shapes

Circular, triangular, square or rectangular shapes are acceptable provided that the bead, intumescent and fixing details are as proven acceptable in test by the intumescent /glazing manufacturers.

### Glass Types

1.	5mm	FIVESTAR	Vetrotech
2.	6mm	PYROSWISS	Vetrotech
3.	6mm	PYROSHIELD	Pilkington
4.	6mm	PYRAN S	Schott
5.	6mm	SUREGLAZE CLEAR max 0.41m <sup>2</sup>	Halspan
6.	6mm	SUREGLAZE WIRED	Halspan
7.	6mm	PYROCET (Securiglass Zeroplus Glazing Ltd)	
8.	6mm	INTERGLAZE E30	Halspan
9.	7mm	PYRODUR PLUS II	Pilkington
10.	7mm	PYROGUARD CLEAR max 0.9m <sup>2</sup>	CGI
11.	7mm	PYROGUARD WIRED	CGI
12.	7mm	SUREGLAZE INSUL	Halspan
13.	7mm	PYROBELITE	Glaverbel
14.	7.5mm	PYRODUR PLUS	Pilkington
15.	10mm	PYRODUR	Pikington
16.	12mm	PYROBELITE	Glaverbel
17.	13mm	PYRODUR	Pilkington
18.	15mm	PYROSTOP	Pilkington
19.	16mm	PYROBEL	Glaverbel

Alternative glasses may be substituted provided they demonstrate adequate performance, in the required pane size, when tested in timber doorsets of comparable construction.

### Design

The maximum areas apply to each door leaf and are applicable for all door configurations offered under the Halspan FD30 specification.

### Circular/Curvilinear glazing

Follow the preceding glazing specifications, with a maximum aperture dimension of 500mm diameter for all leaf sizes and configurations.



Use hardwood bead of  $>650\text{kgm}^3$  density at moisture content  $10 \pm 2\%$ , 15mm deep and a  $25^\circ$  chamfer with bolection moulding not less than 4mm deep.

#### Semi-Circular Glazing

Includes mixed apertures, e.g. D-ended and full semi-circles. Installation as full circles, with restriction to 250mm maximum radius for the curves.

#### Ladder Glazing

This effect is created by applying a single cut-out to one pane of glass. Full details with diagrams are provided in this section.

#### Multi-pane Glazing

Halspan tests permit the use of horizontal and vertical hardwood bars or astragals to sub-divide an aperture. Full details with diagrams are provided in this section.

#### **CAUTION**

All glass types must be fitted strictly in accordance with the manufacturers' tested details and installation requirements.

#### Not Permitted

Glasses proven only by tests in screens are not acceptable.

#### **Safety Glass**

All safety glass fitted to Halspan Doors should have been tested by manufacturers to BS 6206: 1981.

#### **Non-Safety Glass**

Firelite Ceramic Glass, manufactured by Southern Ceramics, is not a safety glass. Its use is restricted to apertures defined as 'small' (Part N of Schedule 1 to the Building Regulations 1991).

Competence of use, of non-safety glass, in fire doors is maintained by application of the following restrictions to all door configurations – sight size not to exceed 250mm wide and an area not exceeding  $0.5\text{m}^2$  maximum.

#### **Note**

*Alternative glazing products are acceptable, provided that they can demonstrate adequate performance in the required pane size and when tested in doorsets of comparable construction.*

HALSPAN FD30

FD30 GLAZING DESIGN OPPORTUNITIES – REFER TO MAXIMUM PERMITTED AREAS

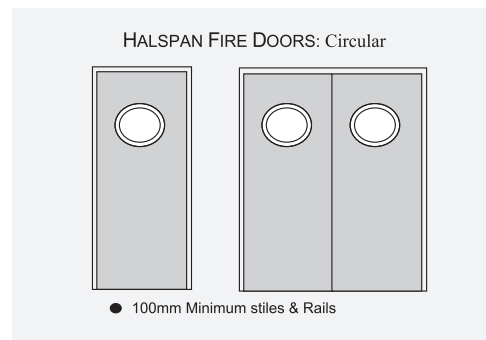
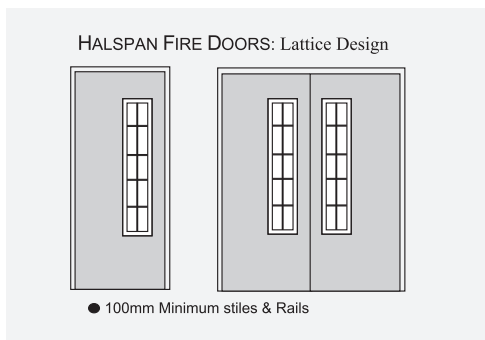
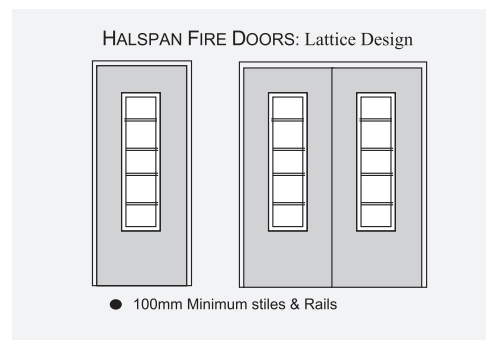
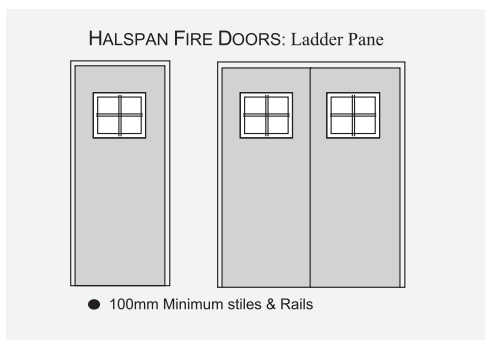
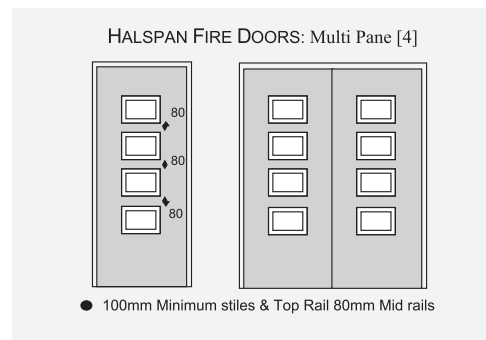
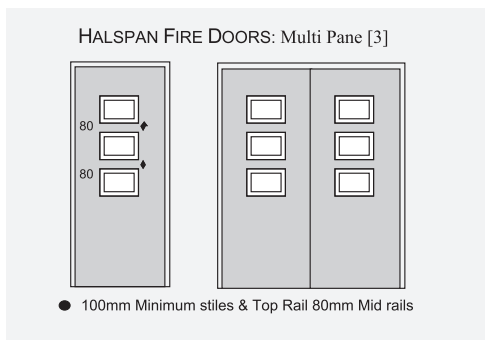
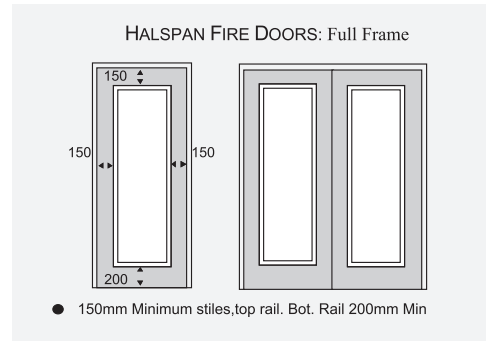
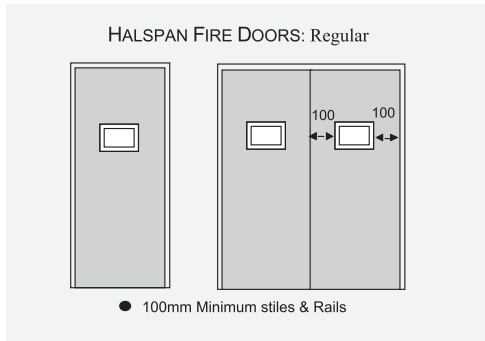

**HALSPAN FD30**

**FD30 GLAZING DESIGN OPPORTUNITIES – REFER TO MAXIMUM PERMITTED AREAS**

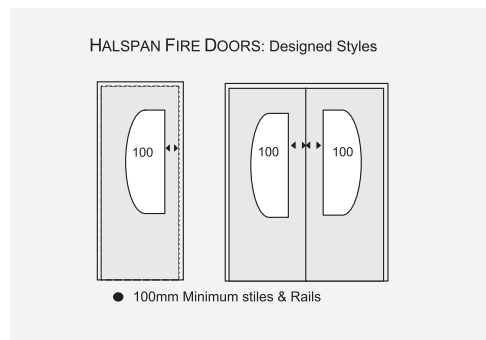
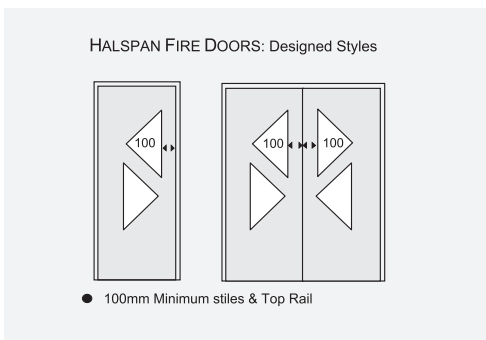
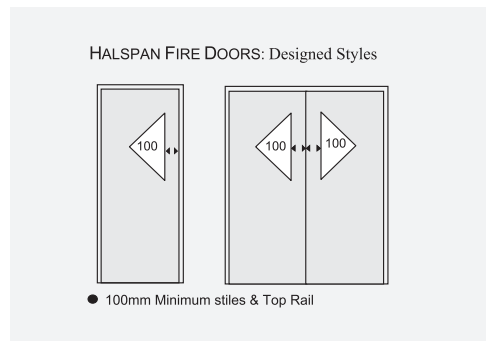
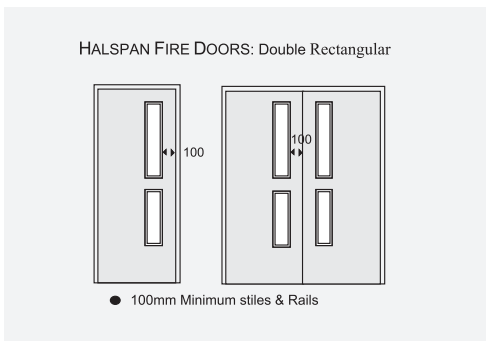
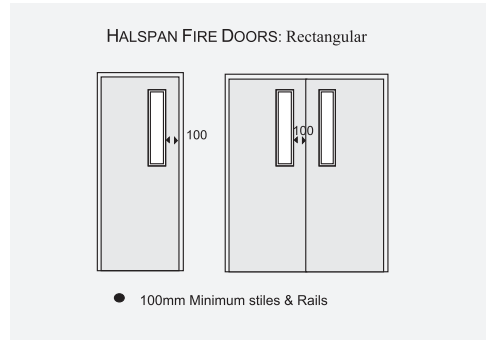
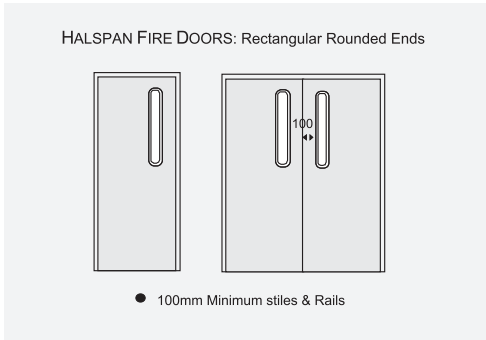

Selection of approved intumescent & glazing systems  
**GUIDE TO BEADING DETAIL FOR GLAZING IN HALSPAN FD30**

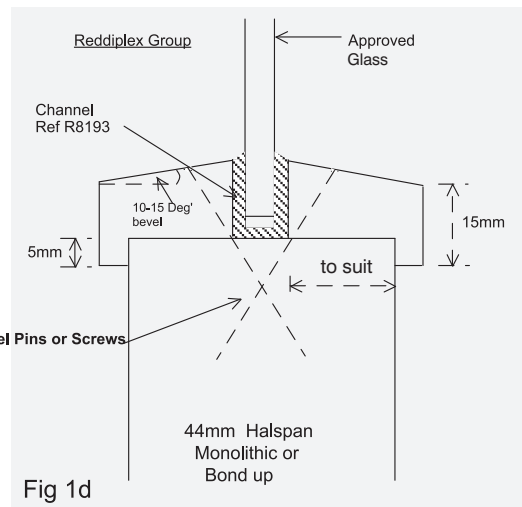
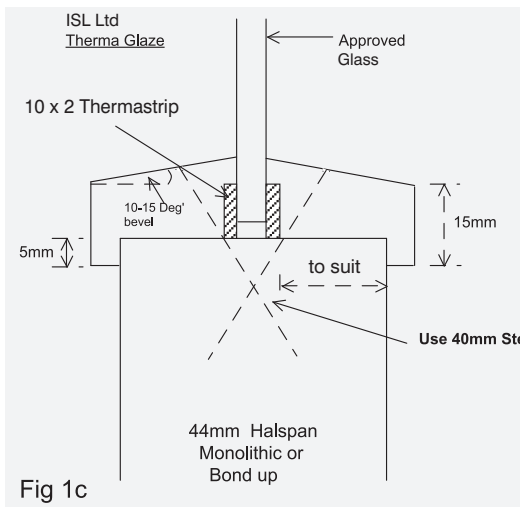
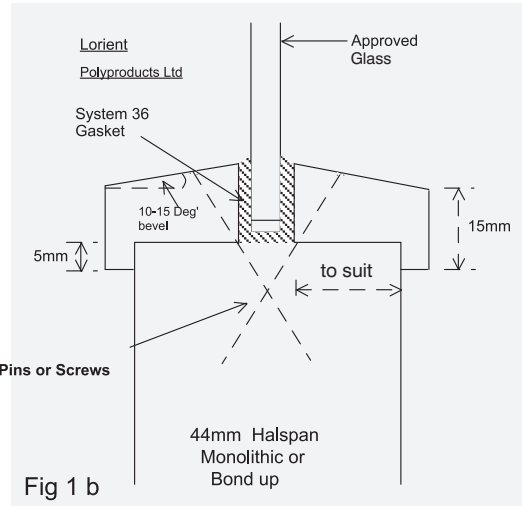
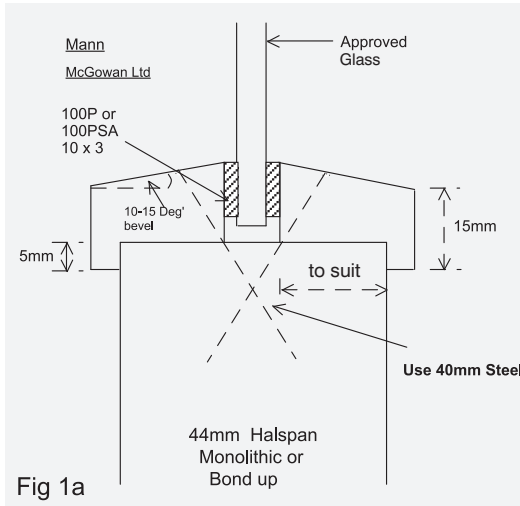



**Selection of approved intumescent & glazing systems**  
**GUIDE TO BEADING DETAIL FOR GLAZING IN HALSPAN FD30**

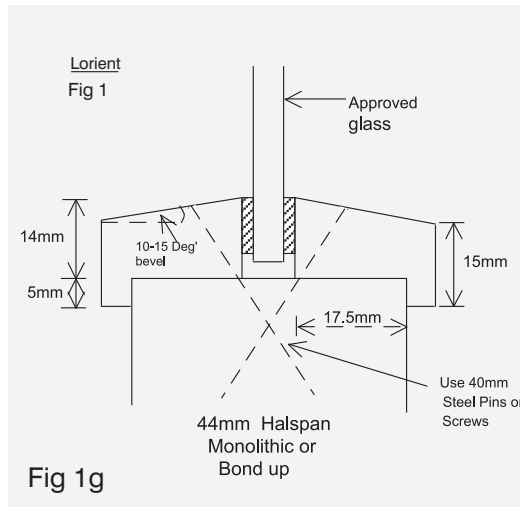
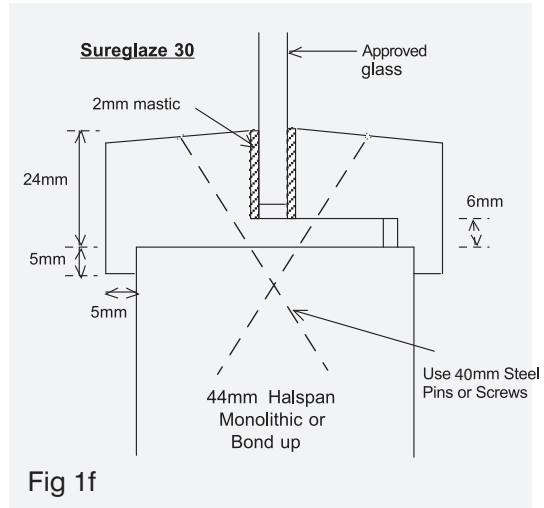
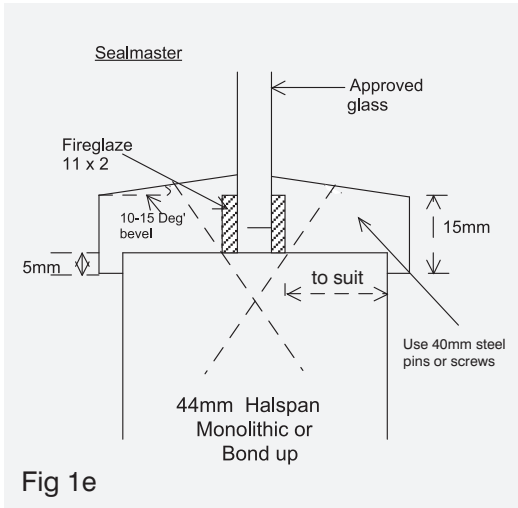

Selection of approved intumescent & glazing systems  
**GUIDE TO BEADING DETAIL FOR GLAZING IN HALSPAN FD30**

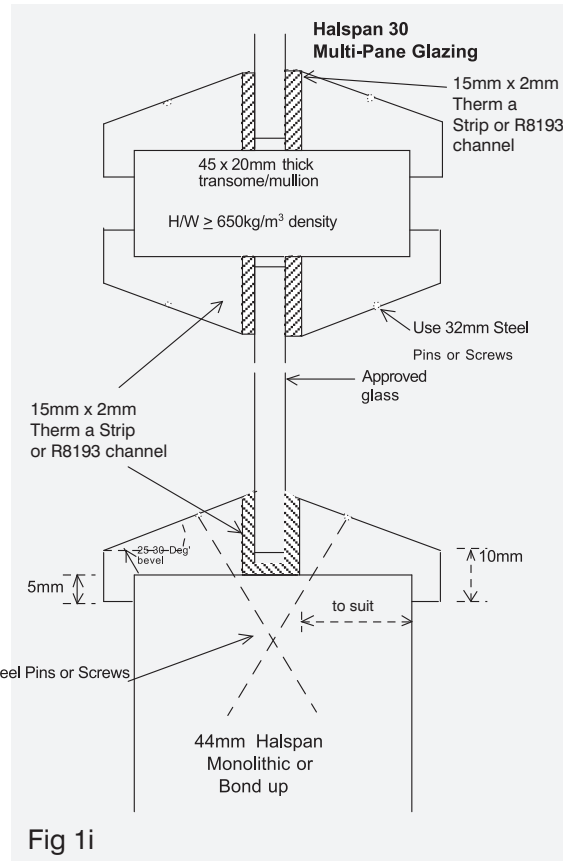
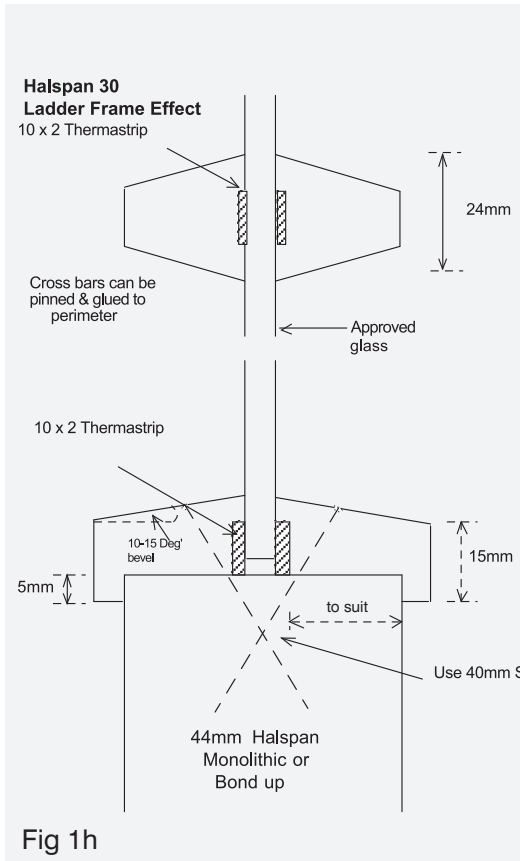

**Selection of approved intumescent & glazing systems**  
**GUIDE TO BEADING DETAIL FOR GLAZING IN HALSPAN FD30**

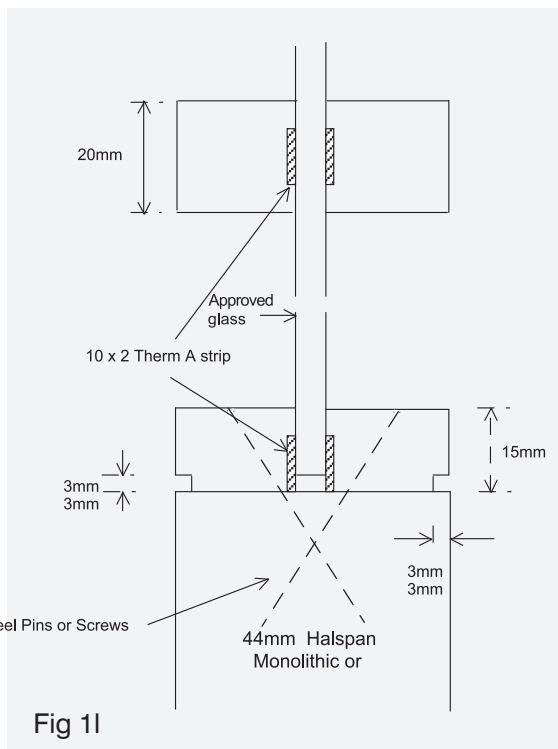
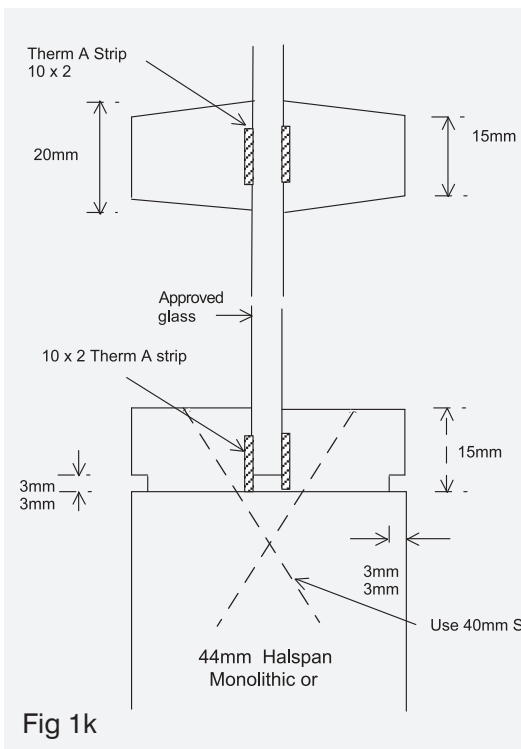
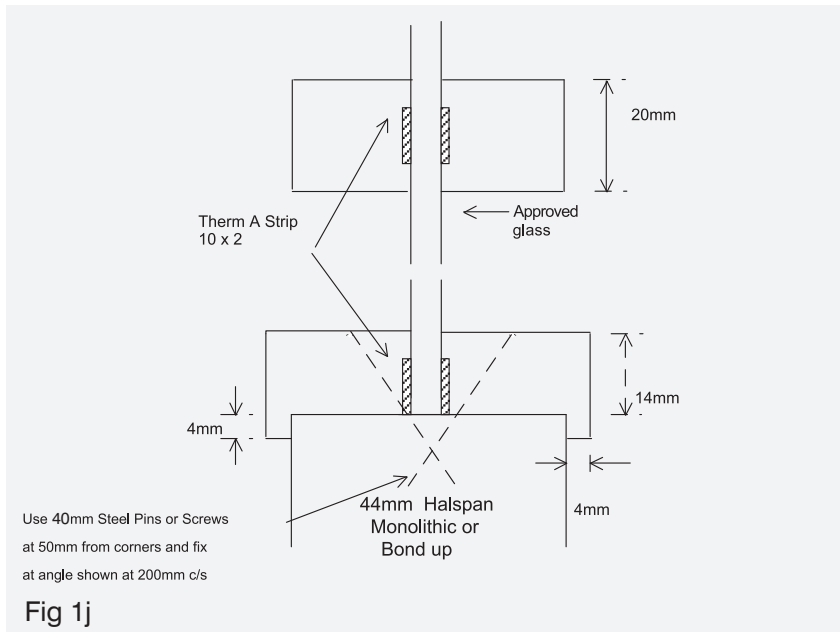

## Selection of approved intumescent &amp; glazing systems

## GUIDE TO BEADING DETAIL FOR GLAZING IN HALSPAN FD30

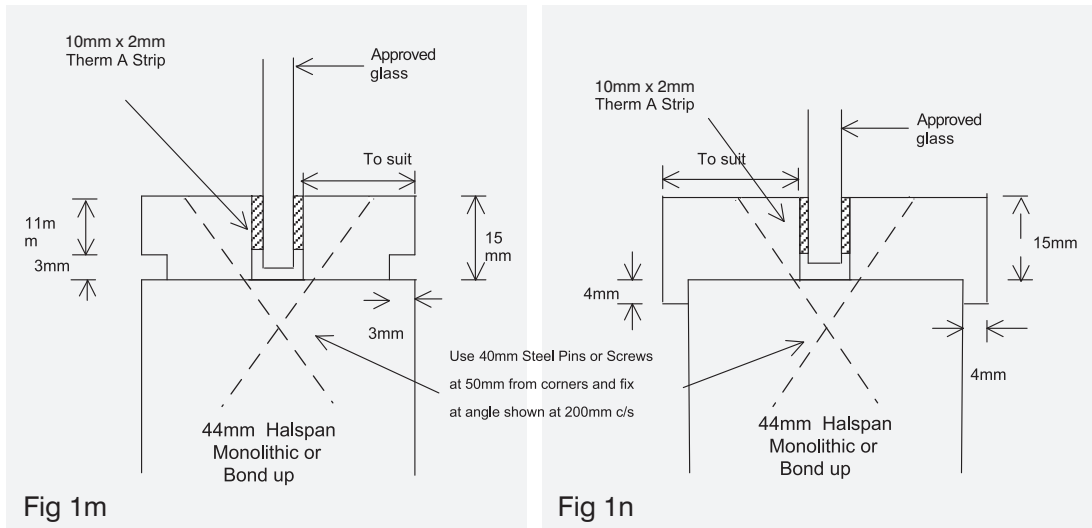

**SAFETY DATA****HANDLING AND STORAGE**

When handling with mechanised handling equipment, such as fork trucks and pallet trucks, care should be taken to observe the weight restrictions of the equipment and safe working practices.

When manually handling, care should be taken to avoid the product sliding through the hands, wearing gloves if frequently handling boards, especially re-cut material.

It is recommended that Halspan is stored in a dry controlled area similar in ambient condition to that intended for further production. Areas for storing the product should be dry and adequately ventilated, making sure the material is not subjected to excesses of humidity and temperature.

**In storage, care should be taken to stack material safely. Store flat and level on at least three equal spaced, equal height bearers.**

**TRANSPORT CONSIDERATIONS**

Ensure that material is adequately packed and properly secured on the vehicle to prevent any movement. Goods should be conveyed in such a manner as to avoid movement and slipping.

Particular care should be taken with laminated products, as the possibility of movement may be increased.

**HEALTH HAZARDS**

This product is bonded using urea formaldehyde resins and in its recently pressed state, or when being cut or worked, may possibly out-gas formaldehyde. The product is manufactured to the emission class E1 of the EU Standard.

Care should be taken to ensure adequate ventilation and control of the environment and to ensure prevention of exposure for persons likely to be particularly sensitive to the effects of formaldehyde, i.e. Asthma sufferers or those likely to contract skin rashes.

When processed, this product produces wood dust which can act as a skin or respiratory irritant. Adequate ventilation and dust and waste extraction should be provided to ensure that the work place complies with COSHH Regulations 1988 and Guidance Note EH40/89.

Adequate control of exposure by employees to formaldehyde and wood dusts will automatically provide control against other aldehydes and amminiacal compounds, which can be produced when machining particle board, especially if blunt tools are used.



C2010

### FIRE AND EXPLOSION

There is no risk of explosion with this product, but users should be aware that airborne wood dust produced during processing could present a fire hazard. Do not smoke.

Ensuring efficient and continuous dust extraction during processing.

The product burns in a similar manner to natural timber. Normal fire fighting procedures should be observed.

### FIRST AID

#### Inhalation of wood dust

- Remove person to fresh air. Clean nasal passages.

#### Wood dust in eyes

- Flush eyes with tepid water for 15 minutes.

#### Affected by formaldehyde

- Remove person to fresh air.

Drink copious volumes of fluid.

- If no recovery is made, immediate medical advice should be sought.

### PERSONAL PROTECTION

An ori-nasal mask to BS6016 and eye shield to BS2092 are recommended.

### IMPORTANT..HANDLING AND STORAGE

On receipt of materials from supplier/distributor

- Store Halspan door blanks horizontally on 3 or more equally spaced bearers. For multiple pack storage ensure that bearers are aligned. KEEP HALSPAN OFF THE FLOOR/GROUND
- Storage conditions prior to fabrication should be as close to the environmental conditions in the workshop as possible. Ideally these should be within the following parameters— 40% to 65% RH and 13°C to 21°C. Halspan should be allowed to condition for 3-4 days prior to processing.
- Halspan should not be exposed to external conditions such as rain, excessive moisture or intense sunlight. The storage area should be well ventilated.
- Avoid Halspan coming into contact with corrosive or staining materials.

# SAFETY DATA

## HALSPAN INSTALLATION GUIDE FIRE DOOR SITE FIXING INSTRUCTIONS

### 1. Surrounding Structure

#### Frame, support wall construction

The frames must be fixed back to stud partitions, blockwork, brickwork or concrete walls, at centres not exceeding 600mm.

Timber 'sub-frames' may be incorporated as a solid packer between the opening in the supporting constructions and the rear face of the frame member of the doorset. The sub-frame must cover the full surface of the rear of frame member, and be continuous for the full doorset height/width. The timber shall be of the same density and structural quality as that specified for the frame itself.

The gap between sub-frame/finished opening plus frame, not to exceed 10mm, should be filled with non-combustible material and capped off with intumescent mastic or the inclusion of an intumescent strip on the reverse of the frame.

### 2. Timber Frames

Frames and stops can be softwood or hardwood for FD30. See the relevant section in this Technical Support Manual for the specification.

The rear of the frame has to be protected. Where sub-frames/extension linings are used, the joint between the main-frame and the sub-frame must not intrude into the plane of the doorset height/width.

Where an integral architrave is used, the face of the door must not protrude beyond the face of the wall. Usually the rear of the frame is protected by the adjacent wall, without excessive gaps, and the frame does not project out from the wall. If not, special assessment will need to be sought.

#### **Stops**

Stops to be minimum 12mm wide, machined from solid or planted, pinned only, using 40mm steel pins.

### **Head/Jamb Joint**

Mortice and tenon or half-lapped joint, head twice screwed to jambs.

### **Architraves**

Architraves are optional and have no performance requirements.

### 3. Hanging Leaves

#### **Gaps**

Doors should be hung to give an equal gap across the head and down both jambs, the gap not to exceed 4mm.

The gap between the door and the frame should not exceed 4mm, the gap at the meeting stile should not exceed 4mm and the doors should not be proud of the frame reveal by more than 1mm.

Smoke seals which require a larger gap should remain within tested tolerances.

### 5. Glazing

On-site cutting of apertures is permissible with Halspan.

For full specification and installation instructions refer to the relevant section in this Technical Support Manual.

### 6. Ironmongery

Large lock forends and bolts require to be bedded on low pressure intumescent.

Door closers should be supplied with intumescent gaskets, wherever applicable. See Halspan Ironmongery section for specification and installation instructions.

Take care with ironmongery as certain items and their fixings may not be compatible with Halspan or other timber cored door constructions.



### 7. Pre-Installation Handling & Storage

If storing finished doors, doorsets and door kits, they should be protected from rain and sun, preferably in a ventilated building.

Fire doors are for internal installation and should also be protected from exposure to excessive moisture and splashing by corrosive or staining materials.

Store horizontally on 3 or more equally spaced bearers, away from floor or ground. Keep in wrappings as long as possible. Site environmental conditions should be within the following parameters: 40% to 60% RH and 13°C to 21°C.

#### Protect glazed doors

Use spacers between stored doors to prevent glazing beads from damage.

#### Unlaquered doors

Should have a coat of seal applied as soon as possible.

#### Laminate faced doors

Refer to manufacturer's guide on care and maintenance.

#### Protect facings

Door assembly timber components that are to receive a clear finish, or veneered surfaces, should not be exposed to strong lights, daylight or uneven light during storage as this can cause differential fading.

### Cleaning veneered doors

Clean veneered doors and panels by wiping with a damp cloth. Do not use abrasive or chemical cleaners. If necessary, use a mild detergent solution.

### Smoke and heat activated seals

Heat activated seals and smoke seals can easily be damaged. When supplied separately, for fixing after installation of the door assembly, they should be kept wrapped in a dry, ventilated environment and be clearly identified.

### 8. Metal Frames

Enquiries regarding aluminium frames may be addressed to Halspan Technical Support by fax or Email at the contact numbers noted in this document.

### Fixing & sealing to Structural openings

Guidance for fixing doorsets, and methods of providing an adequate fire resistant seal to the structural opening, is documented in BS8214: 1990 Code of practice for "Fire door assemblies with non-metallic leaves". This should be referred to where necessary.

### On-site Instructions

These on-site instructions refer only to fire doors manufactured with Halspan high performance door blanks. Otherwise, general application must comply with test requirements of individual suppliers.

**HALSPAN**<sup>®</sup>

INSTALLATION





# NOTES

## Technical Support Manual

Halspan Optima



[www.halspan.com](http://www.halspan.com)

Halspan™ is the registered trademark of Halspan Ltd.