

ETA-Danmark A/S
Kollegievej 6
DK-2920 Charlottenlund
Tel. +45 72 24 59 00
Fax +45 72 24 59 04
Internet www.etadanmark.dk



Authorised and notified according to Article 10 of the Council Directive 89/106/EEC of 21 December 1988 on the approximation of laws, regulations and administrative provisions of Member States relating to construction products

MEMBER OF EOTA

European Technical Approval ETA-12/0114

This ETA replaces the previous ETA with the same number and validity from 2012-07-17 to 2017-07-17

Trade name:	SPAX self-tapping screws
Holder of approval:	SPAX International GmbH & Co. KG Kölner Strasse 71-77 DE-58256 Ennepetal Tel. +49 23 33799-0 Fax + 49 23 33799-199 Internet www.spax.com
Generic type and use of construction product:	Self-tapping screws for use in timber structures
Valid from: to:	2012-09-05 2017-07-17
Manufacturing plant:	SPAX International GmbH & Co. KG Kölner Strasse 71-77 DE-58256 Ennepetal

This European Technical Approval contains: 84 pages including 6 annexes which form an integral part of the document



European Organisation for Technical Approvals

Europæisk Organisation for Tekniske Godkendelser

I LEGAL BASIS AND GENERAL CONDITIONS

1 This European Technical Approval is issued by ETA-Danmark A/S in accordance with:

- Council Directive 89/106/EEC of 21 December 1988 on the approximation of laws, regulations and administrative provisions of Member States relating to construction products¹⁾, as amended by Council Directive 93/68/EEC of 22 July 1993²⁾.
- Bekendtgørelse 559 af 27-06-1994 (afløser bekendtgørelse 480 af 25-06-1991) om ikrafttræden af EF direktiv af 21. december 1988 om indbyrdes tilnærmelse af medlemsstaternes love og administrative bestemmelser om byggevarer.
- Common Procedural Rules for Requesting, Preparing and the Granting of European Technical Approvals set out in the Annex to Commission Decision 94/23/EC³⁾.

2 ETA-Danmark A/S is authorized to check whether the provisions of this European Technical Approval are met. Checking may take place in the manufacturing plant. Nevertheless, the responsibility for the conformity of the products to the European Technical Approval and for their fitness for the intended use remains with the holder of the European Technical Approval.

3 This European Technical Approval is not to be transferred to manufacturers or agents of manufacturers other than those indicated on page 1, or manufacturing plants other than those indicated on page 1 of this European Technical Approval.

4 This European Technical Approval may be withdrawn by ETA-Danmark A/S pursuant to Article 5(1) of Council Directive 89/106/EEC.

- 1) Official Journal of the European Communities N° L40, 11 Feb 1989, p 12.
- 2) Official Journal of the European Communities N° L220, 30 Aug 1993, p 1.
- 3) Official Journal of the European Communities N° L 17, 20 Jan 1994, p 34.

5 Reproduction of this European Technical Approval including transmission by electronic means shall be in full. However, partial reproduction can be made with the written consent of ETA-Danmark A/S. In this case partial reproduction has to be designated as such. Texts and drawings of advertising brochures shall not contradict or misuse the European Technical Approval.

6 This European Technical Approval is issued by ETA-Danmark A/S in English. This version corresponds fully to the version circulated within EOTA. Translations into other languages have to be designated as such.

II SPECIAL CONDITIONS OF THE EUROPEAN TECHNICAL APPROVAL

1 Definition of product and intended use

Definition of the product

SPAX screws are self-tapping screws to be used in timber structures. They shall be threaded over a part or over the full length. SPAX threaded rods shall be threaded over the full length. The screws shall be produced from carbon steel wire for nominal diameters of 2,5 mm to 12,0 mm and from stainless steel wire for nominal diameters of 3,0 mm to 12,0 mm. SPAX threaded rods shall be produced from carbon steel wire or from stainless steel wire for a nominal diameter of 16,0 mm. Where corrosion protection is required, the material or coating shall be declared in accordance with the relevant specification given in Annex A of EN 14592.

Geometry and Material

The nominal diameter (outer thread diameter), d , of SPAX screws shall not be less than 2,5 mm and shall not be greater than 12,0 mm. The nominal diameter of SPAX threaded rods is 16 mm. The overall length of the screws, ℓ , shall not be less than 12 mm and shall not be greater than 800 mm. The overall length of the threaded rods, ℓ , shall not be greater than 3000 mm. Other dimensions are given in Annex A.

The ratio of inner thread diameter to outer thread diameter d_i/d ranges from 0,58 to 0,68.

The screws are threaded over a minimum length ℓ_g of $4 \cdot d$ (i.e. $\ell_g \geq 4 \cdot d$).

The lead p (distance between two adjacent thread flanks) ranges from $0,49 \cdot d$ to $0,61 \cdot d$.

No breaking shall be observed at a bend angle, α , of less than $(45/d^{0,7} + 20)$ degrees.

Intended use

The screws and threaded rods are used for connections in load bearing timber structures between members of solid timber, glued laminated timber, cross-laminated timber, and laminated veneer lumber, similar glued members, wood-based panels or steel. SPAX screws with a thread over the full length and SPAX threaded rods are also used as tensile or compressive reinforcement perpendicular to the grain or as shear reinforcement.

Furthermore SPAX screws with diameters between 6 mm and 12 mm may also be used for the fixing of Thermal insulation material on rafters.

Steel plates and wood-based panels except solid wood panels, laminated veneer lumber and cross laminated timber shall only be located on the side of the screw head. The following wood-based panels may be used:

- Plywood according to EN 636 or European Technical Approval or national provisions that apply at the installation site
- Particleboard according to EN 312 or European Technical Approval or national provisions that apply at the installation site
- Oriented Strand Board according to EN 300 or European Technical Approval or national provisions that apply at the installation site
- Fibreboard according to EN 622-2 and 622-3 or European Technical Approval (minimum density 650 kg/m³) or national provisions that apply at the installation site
- Cement bonded particleboard according to EN 634 or European Technical Approval or national provisions that apply at the installation site
- Solid wood panels according to EN 13353 and EN 13986 or European Technical Approval or national provisions that apply at the installation site
- Cross laminated timber according to European Technical Approval
- Laminated Veneer Lumber according to EN 14374 or European Technical Approval
- Engineered wood products according to European Technical Approval if the ETA of the product includes provisions for the use of self-tapping screws, the provisions of the ETA of the engineered wood product apply

The screws shall be driven into softwood without predrilling or after pre-drilling with a diameter not larger than the inner thread diameter for the length of the threaded part and with a maximum of the smooth shank diameter for the length of the smooth shank. The threaded rods shall be driven into softwood after pre-drilling with the following diameters:

Threaded rod 16 mm Pre-drilling diameter 13 mm

Threaded rod shall only be driven into pre-drilled holes.

The screws or threaded rods are intended to be used in timber connections for which requirements for mechanical resistance and stability and safety in use in the sense of the Essential Requirements 1 and 4 of Council Directive 89/106/EEC shall be fulfilled.

The design of the connections shall be based on the characteristic load-carrying capacities of the screws. The design capacities shall be derived from the characteristic capacities in accordance with Eurocode 5 or an appropriate national code.

The screws or threaded rods are intended for use for connections subject to static or quasi static loading.

The scope of the screws regarding resistance to corrosion shall be defined according to national provisions that apply at the installation site considering environmental conditions. Section 2.7 of this ETA contains the corrosion protection for SPAX screws made from carbon steel and the material number of the stainless steel.

Assumed working life

The assumed intended working life of the screws for the intended use is 50 years, provided that they are subject to appropriate use and maintenance.

The information on the working life should not be regarded as a guarantee provided by the manufacturer or the approval body issuing the ETA. An “assumed intended working life” means that it is expected that, when this working life has elapsed, the real working life may be, in normal use conditions, considerably longer without major degradation affecting the essential requirements.

2 Characteristics of product and assessment

Characteristic		Assessment of characteristic	
2.1 Mechanical resistance and stability*)			
2.1.1	Tensile strength Screws made of carbon steel	Characteristic value $f_{\text{tens,k}}$:	
		d = 2,5 mm:	2,0 kN
		d = 3,0 mm:	2,8 kN
		d = 3,5 mm:	3,8 kN
		d = 4,0 mm:	5,0 kN
		d = 4,5 mm:	6,4 kN
		d = 5,0 mm:	7,9 kN
		d = 6,0 mm:	11 kN
		d = 7,0 mm:	13 kN
		d = 8,0 mm:	17 kN
		d = 10,0 mm:	28 kN
		d = 12,0 mm:	38 kN
	Threaded rods made of carbon steel or stainless steel	d = 16,0 mm:	63 kN
	Screws made of stainless steel	d = 3,0 mm:	2,1 kN
		d = 3,5 mm:	2,9 kN
		d = 4,0 mm:	3,8 kN
		d = 4,5 mm:	4,2 kN
		d = 5,0 mm:	4,9 kN
		d = 6,0 mm:	7,1 kN
		d = 7,0 mm:	10 kN
		d = 8,0 mm:	13 kN
		d = 10,0 mm:	20 kN
		d = 12,0 mm:	28 kN
2.1.2	Insertion moment	Ratio of the characteristic torsional strength to the mean insertion moment: $f_{\text{tor,k}} / R_{\text{tor,mean}} \geq 1,5$	
2.1.3	Torsional strength Screws made of carbon steel	Characteristic value $f_{\text{tor,k}}$:	
		d = 2,5 mm:	0,7 Nm
		d = 3,0 mm:	1,4 Nm
		d = 3,5 mm:	2,0 Nm
		d = 4,0 mm:	3,0 Nm
		d = 4,5 mm:	4,0 Nm
		d = 5,0 mm:	6,0 Nm
		d = 6,0 mm:	10,5 Nm
		d = 7,0 mm:	14,2 Nm
		d = 8,0 mm:	21 Nm
		d = 10,0 mm:	40 Nm
		d = 12,0 mm:	70 Nm
	Screws made of stainless steel	d = 3,0 mm:	1,0 Nm
		d = 3,5 mm:	1,7 Nm
		d = 4,0 mm:	2,4 Nm
		d = 4,5 mm:	3,2 Nm
		d = 5,0 mm:	4,6 Nm
		d = 6,0 mm:	7,0 Nm
		d = 7,0 mm:	8,7 Nm
		d = 8,0 mm:	17 Nm
		d = 10 mm:	28 Nm
		d = 12 mm:	54 Nm

Characteristic		Assessment of characteristic
2.2 Safety in case of fire		
2.2.1	Reaction to fire	The screws are made from steel classified as Euroclass A1 in accordance with EN 1350-1 and EC decision 96/603/EC, amended by EC Decision 2000/605/EC
2.3 Hygiene, health and the environment		
2.3.1	Influence on air quality	No dangerous materials **)
2.4 Safety in use		Not relevant
2.5 Protection against noise		Not relevant
2.6 Energy economy and heat retention		Not relevant
2.7 Related aspects of serviceability		
2.7.1	Durability	The screws have been assessed as having satisfactory durability and serviceability when used in timber structures using the timber species described in Eurocode 5 and subject to the conditions defined by service classes 1, 2 and 3
2.7.2	Serviceability	
2.7.3	Identification	See Annex A

*) See page 4 of this ETA

**) In accordance with <http://europa.eu.int-/comm/enterprise/construction/internal/dangsub/dangmain.htm> In addition to the specific clauses relating to dangerous substances contained in this European Technical Approval, there may be other requirements applicable to the products falling within its scope (e.g. transposed European legislation and national laws, regulations and administrative provisions). In order to meet the provisions of the EU Construction Products Directive, these requirements need also to be complied with, when and where they apply.

2.1 Mechanical resistance and stability

The load-carrying capacities for SPAX screws are applicable to the wood-based materials mentioned in paragraph 1 even though the term timber has been used in the following.

The characteristic lateral load-carrying capacities and the characteristic axial withdrawal capacities of SPAX screws or threaded rods should be used for designs in accordance with Eurocode 5 or an appropriate national code.

Point side penetration length must be $\ell_{ef} \geq 4 \cdot d$, where d is the outer thread diameter of the screw or threaded rod. For the fixing of rafters, point side penetration must be at least 40 mm, $\ell_{ef} \geq 40$ mm.

The mathematical penetration length of the threaded rods shall be limited to 1000 mm even if the actual penetration length is longer.

European Technical Approvals for structural members or wood-based panels must be considered where applicable.

Lateral load-carrying capacity

The characteristic lateral load-carrying capacity of SPAX screws or threaded rods shall be calculated according to EN 1995-1-1:2008 (Eurocode 5) using the outer thread diameter d as the nominal diameter of the screw. The contribution from the rope effect may be considered.

The characteristic yield moment shall be calculated from:

SPAX screws for $2,5 \text{ mm} \leq d \leq 12,0 \text{ mm}$ made of carbon steel:

$$M_{y,k} = 0,15 \cdot 600 \cdot d^{2,6} \quad [\text{Nmm}]$$

SPAX threaded rods:

$$M_{y,k} = 140000 \quad [\text{Nmm}]$$

SPAX screws for $3,0 \text{ mm} \leq d \leq 12,0 \text{ mm}$ made of stainless steel:

$$M_{y,k} = 0,15 \cdot 400 \cdot d^{2,6} \quad [\text{Nmm}]$$

where

d outer thread diameter [mm]
(d_1 in the drawings in the annex)

The embedding strength for screws arranged parallel to the plane of cross laminated timber, independent of the angle between screw axis and grain direction, $0^\circ \leq \alpha \leq 90^\circ$, shall be calculated from:

$$f_{h,k} = 20 \cdot d^{-0,5} \quad [\text{N/mm}^2]$$

unless otherwise specified in the technical specification (ETA or hEN) for the cross laminated timber.

Where

d outer thread diameter [mm]
(d_1 in the drawings in the annex)

The embedding strength for screws or threaded rods in the wide face of cross laminated timber should be assumed as for solid timber based on the characteristic density of the outer layer. If relevant, the angle between force and grain direction of the outer layer should be taken into account.

The direction of the lateral force shall be perpendicular to the screw axis and parallel to the wide face of the cross laminated timber.

For angles $45^\circ \leq \alpha < 90^\circ$ between force and grain direction of the outer layer the characteristic load-carrying capacity may be assumed as 2/3 of the corresponding value for $\alpha = 90^\circ$, if only the penetration depth perpendicular to the wide face is taken into account.

Axial withdrawal capacity

The characteristic axial withdrawal capacity of SPAX screws or threaded rods at an angle of $15^\circ \leq \alpha \leq 90^\circ$ to the grain in solid timber (softwood), glued laminated timber and cross-laminated timber members or at an angle of $30^\circ \leq \alpha \leq 90^\circ$ to the grain in laminated veneer lumber members shall be calculated according to EN 1995-1-1:2008 from:

$$F_{ax,\alpha,Rk} = \frac{n_{ef} \cdot f_{ax,k} \cdot d \cdot \ell_{ef}}{1,2 \cdot \cos^2 \alpha + \sin^2 \alpha} \cdot \left(\frac{\rho_k}{350} \right)^{0,8} \quad [\text{N}]$$

Where

$F_{ax,\alpha,Rk}$ characteristic withdrawal capacity of the screw at an angle α to the grain [N]

n_{ef} effective number of screws according to EN 1995-1-1:2008

$f_{ax,k}$ Characteristic withdrawal parameter
 $2,5 \text{ mm} \leq d \leq 5,0 \text{ mm}$: $f_{ax,k} = 14,0 \text{ N/mm}^2$
 $6,0 \text{ mm} \leq d \leq 8,0 \text{ mm}$: $f_{ax,k} = 12,0 \text{ N/mm}^2$
 $d = 10,0 \text{ mm}$: $f_{ax,k} = 11,5 \text{ N/mm}^2$
 $d = 12,0 \text{ mm}$: $f_{ax,k} = 11,0 \text{ N/mm}^2$
 $d = 16,0 \text{ mm}$: $f_{ax,k} = 10,0 \text{ N/mm}^2$

d outer thread diameter [mm]
(d_1 in the drawings in the annex)

ℓ_{ef} Penetration length of the threaded part according to EN 1995-1-1:2008 [mm]

α Angle between grain and screw axis ($\alpha \geq 15^\circ$)

ρ_k Characteristic density [kg/m^3]

For screws penetrating more than one layer of cross laminated timber, the different layers may be taken into account proportionally.

The axial withdrawal capacity is limited by the head pull-through capacity and the tensile or compressive capacity of the screw or threaded rod.

Head pull-through capacity

The characteristic head pull-through capacity of SPAX screws or threaded rods shall be calculated according to EN 1995-1-1:2008 from:

$$F_{ax,\alpha,Rk} = n_{ef} \cdot f_{head,k} \cdot d_h^2 \cdot \left(\frac{\rho_k}{350} \right)^{0,8} \quad [N]$$

where:

$F_{ax,\alpha,Rk}$	Characteristic head pull-through capacity of the connection at an angle $\alpha \geq 30^\circ$ to the grain [N]
n_{ef}	Effective number of screws according to EN 1995-1-1:2008
$f_{head,k}$	Characteristic head pull-through parameter [N/mm ²]
d_h	Diameter of the screw head or the washer [mm]. Outer diameter of heads or washers $d_h > 32$ mm shall only be considered with a nominal diameter of 32 mm. (d_k in the drawings in the annex)
ρ_k	Characteristic density [kg/m ³], for wood-based panels $\rho_k = 380$ kg/m ³

Characteristic head pull-through parameter for SPAX screws with countersunk or hexagon head without flange in connections with timber and in connections with wood-based panels with thicknesses above 20 mm:

$$d_h \leq 16 \text{ mm: } f_{head,k} = 27,0 - d_h \text{ [N/mm}^2\text{]}$$

$$16 \text{ mm} < d_h \leq 32 \text{ mm: } f_{head,k} = 11,0 - 0,2 \cdot (d_h - 16) \text{ [N/mm}^2\text{]}$$

Characteristic head pull-through parameter for SPAX screws with washer head, pan head, hexagon head with flange or countersunk head with washer in connections with timber and in connections with wood-based panels with thicknesses above 20 mm:

$$d_h \leq 16 \text{ mm: } f_{head,k} = 29,0 - d_h \text{ [N/mm}^2\text{]}$$

$$16 \text{ mm} < d_h \leq 22 \text{ mm: } f_{head,k} = 13,0 \text{ [N/mm}^2\text{]}$$

$$22 \text{ mm} < d_h \leq 32 \text{ mm: } f_{head,k} = 16,0 - 0,5 \cdot (d_h - 16) \text{ [N/mm}^2\text{]}$$

Characteristic head pull-through parameter for screws in connections with wood-based panels with thicknesses between 12 mm and 20 mm:

$$f_{head,k} = 8 \text{ N/mm}^2$$

Screws in connections with wood-based panels with a thickness below 12 mm (minimum thickness of the wood based panels of $1,2 \cdot d$ with d as outer thread diameter):

$$f_{head,k} = 8 \text{ N/mm}^2$$

limited to $F_{ax,Rk} = 400 \text{ N}$

For SPAX screws or threaded rods, the withdrawal capacity of the thread in the member with the screw head may be taken into account instead of the head pull-through capacity.

The head diameter d_h shall be greater than $1,8 \cdot d_s$, where d_s is the smooth shank or the wire diameter. Otherwise the characteristic head pull-through capacity $F_{ax,\alpha,Rk} = 0$.

The minimum thickness of wood-based panels according to the clause 2.1 must be observed.

In steel-to-timber connections the head pull-through capacity is not governing.

Tensile capacity

The characteristic tensile strength $f_{tens,k}$ of SPAX screws made of carbon steel or threaded rods made of carbon steel or stainless steel is:

$d = 2,5 \text{ mm:}$	2,0 kN
$d = 3,0 \text{ mm:}$	2,8 kN
$d = 3,5 \text{ mm:}$	3,8 kN
$d = 4,0 \text{ mm:}$	5,0 kN
$d = 4,5 \text{ mm:}$	6,4 kN
$d = 5,0 \text{ mm:}$	7,9 kN
$d = 6,0 \text{ mm:}$	11 kN
$d = 7,0 \text{ mm:}$	13 kN
$d = 8,0 \text{ mm:}$	17 kN
$d = 10,0 \text{ mm:}$	28 kN
$d = 12,0 \text{ mm:}$	38 kN

Threaded rods $d = 16 \text{ mm:}$ 63 kN

The characteristic tensile strength $f_{tens,k}$ of SPAX screws made of stainless steel is:

$d = 3,0 \text{ mm:}$	2,1 kN
$d = 3,5 \text{ mm:}$	2,9 kN
$d = 4,0 \text{ mm:}$	3,8 kN
$d = 4,5 \text{ mm:}$	4,2 kN
$d = 5,0 \text{ mm:}$	4,9 kN
$d = 6,0 \text{ mm:}$	7,1 kN
$d = 7,0 \text{ mm:}$	10 kN
$d = 8,0 \text{ mm:}$	13 kN
$d = 10,0 \text{ mm:}$	20 kN
$d = 12,0 \text{ mm:}$	28 kN

For screws or threaded rods used in combination with steel plates, the tear-off capacity of the screw head including a washer shall be greater than the tensile capacity of the screw.

Combined laterally and axially loaded screws or threaded rods

For connections subjected to a combination of axial and lateral load, the following expression should be satisfied:

$$\left(\frac{F_{ax,Ed}}{F_{ax,Rd}}\right)^2 + \left(\frac{F_{la,Ed}}{F_{la,Rd}}\right)^2 \leq 1$$

where

- $F_{ax,Ed}$ axial design load of the screw or threaded rod
 $F_{la,Ed}$ lateral design load of the screw or threaded rod
 $F_{ax,Rd}$ design load-carrying capacity of an axially loaded screw or threaded rod
 $F_{la,Rd}$ design load-carrying capacity of a laterally loaded screw or threaded rod

Mechanically jointed beams

See annex B

Compressive capacity

The characteristic compressive capacity $F_{ax,Rk}$ of SPAX screws or threaded rods with full thread along the length embedded in timber shall be calculated from:

$$F_{ax,Rk} = \min \left\{ f_{ax,k} \cdot d \cdot \ell_{ef} ; \kappa_c \cdot N_{pl,k} \right\} \quad [N]$$

where

$$\kappa_c = \begin{cases} 1 & \text{for } \bar{\lambda}_k \leq 0,2 \\ \frac{1}{k + \sqrt{k^2 - \bar{\lambda}_k^2}} & \text{for } \bar{\lambda}_k > 0,2 \end{cases}$$

$$k = 0,5 \cdot \left[1 + 0,49 \cdot (\bar{\lambda}_k - 0,2) + \bar{\lambda}_k^2 \right]$$

The relative slenderness ratio shall be calculated from:

$$\bar{\lambda}_k = \sqrt{\frac{N_{pl,k}}{N_{ki,k}}}$$

Where

$$N_{pl,k} = \pi \cdot \frac{d_1^2}{4} \cdot f_{y,k} \quad [N]$$

is the characteristic value for the axial capacity in case of plastic analysis referred to the inner thread cross section.

Characteristic yield strength:

$$f_{y,k} = 1000 \text{ [N/mm}^2\text{]} \\ \text{for SPAX screws made of carbon steel}$$

$$f_{y,k} = 500 \text{ [N/mm}^2\text{]} \\ \text{for SPAX threaded rods and SPAX screws made of stainless steel}$$

Characteristic ideal elastic buckling load:

$$N_{ki,k} = \sqrt{c_h \cdot E_S \cdot I_S} \quad [N]$$

Elastic foundation of the screw:

$$c_h = (0,19 + 0,012 \cdot d) \cdot \rho_k \cdot \left(\frac{90^\circ + \alpha}{180^\circ} \right) \quad [\text{N/mm}^2]$$

for screws in cross-laminated timber, the most unfavourable combination of α and ρ_k governs;

Modulus of elasticity:

$$E_s = 210000 \quad [\text{N/mm}^2]$$

$$\rho_k = \text{characteristic density} \quad [\text{kg/m}^3]$$

Second moment of area:

$$I_s = \frac{\pi}{64} \cdot d_1^4 \quad [\text{mm}^4]$$

$$d_1 = \text{inner thread diameter} \quad [\text{mm}]$$

(d_2 in the drawings in the annex)

α = angle between screw axis and grain direction

Note: When determining design values of the compressive capacity it should be considered that $f_{ax,d}$ is to be calculated using k_{mod} and γ_M for timber according to EN 1995 while $N_{pl,d}$ is calculated using $\gamma_{M,0}$ for steel according to EN 1993.

Compression reinforcement

See annex C

Tensile reinforcement

See annex D

Shear reinforcement

See annex E

Thermal insulation material on top of rafters

See annex F

2.7 Related aspects of serviceability

2.7.1 Corrosion protection in service class 1, 2 and 3.

The SPAX screws and threaded rods are produced from carbon wire. They are brass-plated, nickel-plated bronze finished or electrogalvanised and e.g. yellow or blue chromated with thicknesses of the zinc coating from 4 – 16 μm or have a zinc flake coating with thicknesses from 10 – 20 μm .

Steel no. 1.4016, 1.4401, 1.4567, 1.4578, 1.4529 and 1.4539 is used for screws made from stainless steel.

3 Attestation of Conformity and CE marking

3.1 Attestation of Conformity system

The system of attestation of conformity is 2+ described in Council Directive 89/106/EEC (Construction Products Directive) Annex III.

a) Tasks for the manufacturer:

- (1) Factory production control,
- (2) Initial type testing of the product,

b) Tasks for the notified body:

- (1) Initial inspection of the factory and the factory production control,
- (2) Continuous surveillance

3.2 Responsibilities

3.2.1 Tasks of the manufacturer

3.2.1.1 Factory production control

The manufacturer has a factory production control system in the plant and exercises permanent internal control of production. All the elements, requirements and provisions adopted by the manufacturer are documented in a systematic manner in the form of written policies and procedures. This production control system ensures that the product is in conformity with the European Technical Approval.

The manufacturer shall only use raw materials supplied with the relevant inspection documents as laid down in the control plan⁴. The incoming raw materials shall be subject to controls and tests by the manufacturer before acceptance. Check of raw materials, such as metal wire, shall include control of the inspection documents presented by suppliers (comparison with nominal values) by verifying dimension and determining material properties.

The manufactured components shall be subject to the following checks:

- Raw material specification;
- Dimension of the screws or threaded rods;
- Characteristic tensile strength $f_{\text{tens},k}$;
- Characteristic torsional strength $f_{\text{tor},k}$;

- Characteristic insertion moment $R_{\text{tor},k}$;
- Durability;
- Marking.

The control plan, which is part of the technical documentation of this European Technical Approval, includes details of the extent, nature and frequency of testing and controls to be performed within the factory production control and has been agreed between the approval holder and ETA Danmark.

The results of factory production control are recorded and evaluated. The records include at least the following information:

- Designation of the product, basic material and components;
- Type of control or testing;
- Date of manufacture of the product and date of testing of the product or basic material and components;
- Result of control and testing and, if appropriate, comparison with requirements;
- Signature of person responsible for factory production control.

The records shall be presented to ETA Danmark on request.

3.2.1.1 Initial type testing of the product

For initial type-testing the results of the tests performed as part of the assessment for the European Technical Approval shall be used unless there are changes in the production line or plant. In such cases the necessary initial type testing has to be agreed between ETA Danmark and the notified body.

The initial type testing shall be subject to the following checks:

- Raw material specification;
- Dimension of the screws or threaded rods;
- Characteristic yield moment $M_{y,k}$;
- Characteristic withdrawal parameter $f_{\text{ax},k}$;
- Characteristic head pull-through parameter $f_{\text{head},k}$;
- Characteristic tensile strength $f_{\text{tens},k}$;
- Characteristic yield strength if relevant;
- Characteristic torsional strength $f_{\text{tor},k}$;
- Characteristic insertion moment $R_{\text{tor},k}$;
- Durability.

3.2.2. Tasks of notified bodies

3.2.2.1 Initial inspection of the factory and the factory production control

⁴ The control plan has been deposited at ETA-Danmark and is only made available to the approved bodies involved in the conformity attestation procedure.

The approved body should ascertain that, in accordance with the control plan, the factory, in particular the staff and equipment, and the factory production control, are suitable to ensure a continuous and orderly manufacturing of the screws with the specifications given in part 2.

3.2.2.2 Continuous surveillance

The approved body shall visit the factory at least once a year for routine inspections. It shall be verified that the system of factory production control and the specified manufacturing processes are maintained, taking account of the control plan.

The results of product certification and continuous surveillance shall be made available on demand by the certification body to ETA Danmark. Where the provisions of the European Technical Approval and the control plan are no longer fulfilled, the certificate of conformity shall be withdrawn by the approved body.

3.3 CE marking

The CE marking shall be affixed on each packaging of screws. The initials "CE" shall be followed by the identification number of the notified body and shall be accompanied by the following information:

- Name or identifying mark of the manufacturer
- The last two digits of the year in which the marking was affixed
- Number of the European Technical Approval
- Name of product
- Outer thread diameter and length of the self-tapping screws
- Type and mean thickness of the corrosion protection, if relevant
- Stainless steel including the material number, if relevant
- Number of the EC Certificate of Conformity

4 Assumptions under which the fitness of the product for the intended use was favourably assessed

4.1 Manufacturing

The screws or threaded rods are manufactured in accordance with the provisions of the European Technical Approval using the automated manufacturing process as identified during the inspection of the plant by the approval body issuing the ETA and the approved body and laid down in the technical documentation.

4.2 Installation

4.2.1 The installation shall be carried out in accordance with Eurocode 5 or an appropriate national code unless otherwise is defined in the following. Instructions from SPAX International GmbH & Co. KG should be considered for installation.

4.2.2 The screws or threaded rods are used for connections in load bearing timber structures between members of solid timber (softwood), glued laminated timber, cross-laminated timber (minimum diameter $d = 6,0$ mm), and laminated veneer lumber, similar glued members, wood-based panels or steel members. To connect cross-laminated timber the inner thread diameter d_1 of the screws shall be greater than the maximal width of the gaps in the layer.

The screws or threaded rods may be used for connections in load bearing timber structures with structural members according to an associated European Technical Approval, if according to the associated European Technical Approval of the structural member a connection in load bearing timber structures with screws according to a European Technical Approval is allowed.

SPAX fully threaded screws or threaded rods are also used as tensile or compressive reinforcement perpendicular to the grain or as shear reinforcement.

Furthermore the screws with diameters between 6 mm and 12 mm may also be used for the fixing of insulation on top of rafters.

A minimum of two screws or threaded rods should be used for connections in load bearing timber structures.

The minimum penetration depth in structural members made of solid, glued or cross-laminated timber is $4 \cdot d$.

Wood-based panels and steel plates should only be arranged on the side of the screw head. The minimum thickness of wood-based panels should be $1,2 \cdot d$. Furthermore the minimum thickness for following wood-based panels should be:

- Plywood, Fibreboards: 6 mm
- Particleboards, OSB, Cement Particleboards: 8 mm

- Solid wood panels: 12 mm

For structural members according to European Technical Approvals the terms of the European Technical Approvals must be considered.

If screws with an outer thread diameter $d \geq 8$ mm are used in load bearing timber structures, the structural solid or glued laminated timber, laminated veneer lumber and similar glued members must be from spruce, pine or fir. This does not apply for screws or threaded rods in pre-drilled holes.

The minimum angle between the screw axis and the grain direction is $\alpha = 15^\circ$.

4.2.3 The screws shall be driven into softwood without predrilling or after pre-drilling with a diameter not larger than the inner thread diameter for the length of the threaded part and with a maximum of the smooth shank diameter for the length of the smooth shank. The threaded rods shall be driven into softwood after pre-drilling with the following diameters:

Threaded rod 16 mm Pre-drilling diameter 13 mm

Threaded rod shall only be driven into pre-drilled holes

The hole diameter in steel members must be predrilled with a suitable diameter.

Only the equipment prescribed by SPAX GmbH & Co. KG shall be used for driving the screws.

In connections with screws with countersunk head according to Annex A the head must be flush with the surface of the connected structural member. A deeper countersink is not allowed.

4.2.4 Unless otherwise specified, minimum thickness for non-predrilled structural members is $t = 24$ mm for screws with outer thread diameter $d < 8$ mm, $t = 30$ mm for screws with outer thread diameter $d = 8$ mm, $t = 40$ mm for screws with outer thread diameter $d = 10$ mm and $t = 80$ mm for screws with outer thread diameter $d = 12$ mm.

For structural timber members, minimum spacing and distances for screws in predrilled holes are given in EN 1995-1-1:2008 (Eurocode 5) clause 8.3.1.2 and table 8.2 as for nails in predrilled holes. These minimum spacing and distances also apply for SPAX screws with CUT or 4CUT drill tip in non-predrilled holes. Here, the outer thread diameter d must be considered. For SPAX screws with CUT or 4CUT drill tip in non-predrilled holes the following conditions shall be fulfilled:

- $a_1 \geq 5 \cdot d$
- $a_{3,c} \geq 12 \cdot d$
- $a_{3,t} \geq 12 \cdot d$
- minimum cross-section $\geq 40 d^2$

- screws with CUT drill tip:

$t_{\min} = \max \{5 \cdot d; 20 \text{ mm}\}$	for $d \leq 6 \text{ mm}$
$t_{\min} = 7 \cdot d$	for $d \geq 8 \text{ mm}$
- screws with 4CUT drill tip:

$t_{\min} = \max \{6 \cdot d; 20 \text{ mm}\}$	for $d \leq 6 \text{ mm}$
$t_{\min} = 7 \cdot d$	for $d \geq 8 \text{ mm}$

For SPAX screws not fulfilling the above conditions or for screws in laminated veneer lumber, minimum spacing and distances are given in EN 1995-1-1:2008 clause 8.3.1.2 and Table 8.2 as for nails in non-predrilled holes.

Alternatively, minimum distances and spacing for exclusively axially loaded SPAX screws with CUT or 4CUT drill tip or with $d \leq 8 \text{ mm}$ in non-predrilled holes in members of solid timber, glued laminated timber or similar glued products with a minimum thickness $t = 12 \cdot d$ may be taken as:

Spacing a_1 parallel to the grain	$a_1 = 5 \cdot d$
Spacing a_2 perpendicular to the grain	$a_2 = 5 \cdot d$
Distance $a_{3,c}$ from centre of the screw-part in timber to the end grain	$a_{3,c} = 5 \cdot d$
Distance $a_{4,c}$ from centre of the screw-part in timber to the edge	$a_{4,c} = 4 \cdot d$
Distance $a_{4,c}$ from centre of the screw-part in timber to the edge for screws with CUT or 4CUT drill tip only	$a_{4,c} = 3 \cdot d$

Spacing a_2 perpendicular to the grain may be reduced from $5 \cdot d$ to $2,5 \cdot d$, if the condition $a_1 \cdot a_2 \geq 25 \cdot d^2$ is fulfilled.

Alternatively, minimum distances and spacing for exclusively axially loaded SPAX screws in laminated veneer members with a minimum thickness $t = 6 \cdot d$ may be taken as:

Spacing a_1 parallel to the grain	$a_1 = 5 \cdot d$
Spacing a_2 perpendicular to the grain	$a_2 = 5 \cdot d$
Distance $a_{3,c}$ from centre of the screw-part in timber to the end grain	$a_{3,c} = 5 \cdot d$
Distance $a_{4,c}$ from centre of the screw-part in timber to the edge	$a_{4,c} = 3 \cdot d$

Spacing a_2 perpendicular to the grain may be reduced from $5 \cdot d$ to $2,5 \cdot d$, if the condition $a_1 \cdot a_2 \geq 25 \cdot d^2$ is fulfilled.

For Douglas fir members minimum spacing and distances parallel to the grain shall be increased by 50%.

Minimum distances from loaded or unloaded ends must be $15 \cdot d$ for screws in non-predrilled holes with outer thread diameter $d \geq 8 \text{ mm}$ and timber thickness $t < 5 \cdot d$.

Minimum distances from the unloaded edge perpendicular to the grain may be reduced to $3 \cdot d$ also for timber thickness $t < 5 \cdot d$, if the spacing parallel to the grain and the end distance is at least $25 \cdot d$.

Unless specified otherwise in the technical specification (ETA or hEN) of cross laminated timber, minimum distances and spacing for screws in the wide face of cross laminated timber members with a minimum thickness $t = 10 \cdot d$ may be taken as (see Annex B):

Spacing a_1 parallel to the grain	$a_1 = 4 \cdot d$
Spacing a_2 perpendicular to the grain	$a_2 = 2,5 \cdot d$
Distance $a_{3,c}$ from centre of the screw-part in timber to the unloaded end grain	$a_{3,c} = 6 \cdot d$
Distance $a_{3,t}$ from centre of the screw-part in timber to the loaded end grain	$a_{3,t} = 6 \cdot d$
Distance $a_{4,c}$ from centre of the screw-part in timber to the unloaded edge	$a_{4,c} = 2,5 \cdot d$
Distance $a_{4,t}$ from centre of the screw-part in timber to the loaded edge	$a_{4,t} = 6 \cdot d$

Unless specified otherwise in the technical specification (ETA or hEN) of cross laminated timber, minimum distances and spacing for screws in the edge surface of cross laminated timber members with a minimum thickness $t = 10 \cdot d$ and a minimum penetration depth perpendicular to the edge surface of $10 \cdot d$ may be taken as (see Annex B):

Spacing a_1 parallel to the CLT plane	$a_1 = 10 \cdot d$
Spacing a_2 perpendicular to the CLT plane	$a_2 = 4 \cdot d$
Distance $a_{3,c}$ from centre of the screw-part in timber to the unloaded end	$a_{3,c} = 7 \cdot d$
Distance $a_{3,t}$ from centre of the screw-part in timber to the loaded end	$a_{3,t} = 12 \cdot d$
Distance $a_{4,c}$ from centre of the screw-part in timber to the unloaded edge	$a_{4,c} = 3 \cdot d$
Distance $a_{4,t}$ from centre of the screw-part in timber to the loaded edge	$a_{4,t} = 6 \cdot d$

For a crossed screw couple the minimum spacing between the crossing screws is $1,5 \cdot d$.

Minimum distances and spacing for SPAX screws in mechanically jointed beams are given in Annex B.

4.3 Maintenance and repair

Maintenance is not required during the assumed intended working life. Should repair prove necessary, it is normal to replace the screw.

Thomas Bruun
Manager, ETA-Danmark

Annex A
Drawings, designation and material specification of SPAX screws

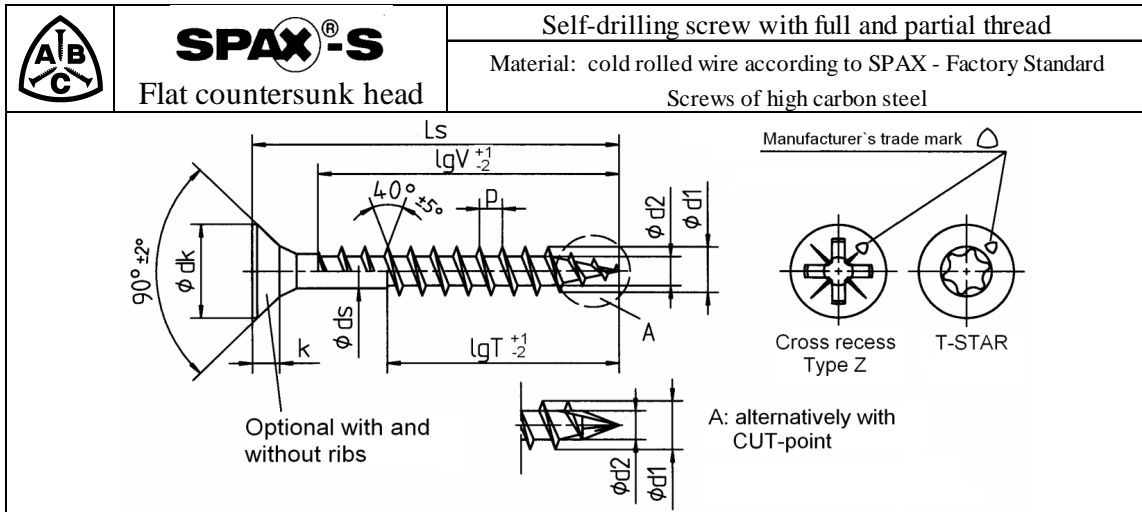

Nominal diameter	2,5	3,0	3,5	4,0	4,5	5,0	6,0									
d1 thread size	2,5	3,0	3,5	4,0	4,5	5,0	6,0									
permissible tolerance	±0,15															
dk head diameter	5,1	6,0	7,0	8,0	8,8	9,7	11,6									
permissible tolerance	-0,40						-0,43									
d2 core diameter	1,7	2,0	2,2	2,5	2,8	3,1	3,8									
permissible tolerance	-0,25					-0,30										
ds shank diameter	1,8	2,15	2,45	2,85	3,20	3,55	4,30									
permissible tolerance	±0,10															
k head height max.	1,6	1,8	2,1	2,4	2,7	2,9	3,4									
p thread pitch	1,3	1,5	1,8	2,0	2,2	2,5	3,0									
permissible tolerance	±0,1 x p															
T-STAR size	T8	T10	T15	T20		T25	T30									
Cross recess size Type Z	1		2				3									
Ls	Standard thread lengths (full thread = lgV / partial thread = lgT)															
Nom.dim.	min	max	lgV	lgT	lgV	lgT	lgV	lgT	lgV	lgT	lgV	lgT	lgV	lgT	lgV	lgT
12	12,0	13,5	10,0													
15	14,0	15,5	12,0		12,5											
16	16,0	17,5	14,0		14,0											
20	18,5	20,5	17,0	12,0	17,0		16,0		16,0							
25	23,5	25,5	22,0	18,0	21,0	18,0	21,0	18,0	21,0		20,0		20,0			
30	28,5	30,5	27,0	18,0	26,0	18,0	25,0	18,0	25,0	18,0	25,0		25,0		24,0	
35	33,5	36,0		22,0	31,0	23,0	30,0	23,0	30,0	23,0	30,0	25,0	30,0	25,0	29,0	24,0
40	38,5	41,0		22,0	36,0	23,0	35,0	23,0	35,0	23,0	34,0	25,0	35,0	27,0	34,0	24,0
45	43,5	46,0		28,0		28,0	40,0	30,0	40,0	30,0	39,0	30,0	39,0	30,0	38,0	29,0
50	48,5	51,0				28,0	40,0	32,0	45,0	32,0	44,0	32,0	44,0	32,0	43,0	32,0
55	53,5	56,0				36,0		35,0	50,0	35,0	49,0	37,0	49,0	37,0	48,0	37,0
60	58,5	61,0						35,0	50,0	35,0	54,0	37,0	54,0	37,0	53,0	37,0
65	63,5	66,0						40,0		37,5	59,0	42,0	59,0	41,0	58,0	41,0
70	68,5	71,0								37,5	59,0	42,0	61,0	41,0	61,0	41,0
75	73,5	76,0								37,5		42,0	61,0	41,0	61,0	41,0
80	78,5	81,0								37,5		47,0	61,0	46,0	61,0	46,0
90	88,5	91,5										47,0		61,0		61,0
100	98,5	101,5												61,0		61,0
110	108,5	111,5												69,0		68,0
120	118,5	121,5												69,0		68,0
130	128,0	132,0														68,0
140	138,0	142,0														68,0
150	148,0	152,0														68,0
160	158,0	162,0														68,0

Screws of Ø6,0mm with partial thread additionally in length of 180 to 300mm, in steps of 20mm, LgT= 68,0 mm

Other thread lengths in the range ≥4xd1 to max. standard length permitted.

Intermediate lengths on Ls possible

	SPAX®-S Flat countersunk head	Self-drilling screw with full and partial thread Material: cold rolled wire according to SPAX - Factory Standard Screws of high carbon steel

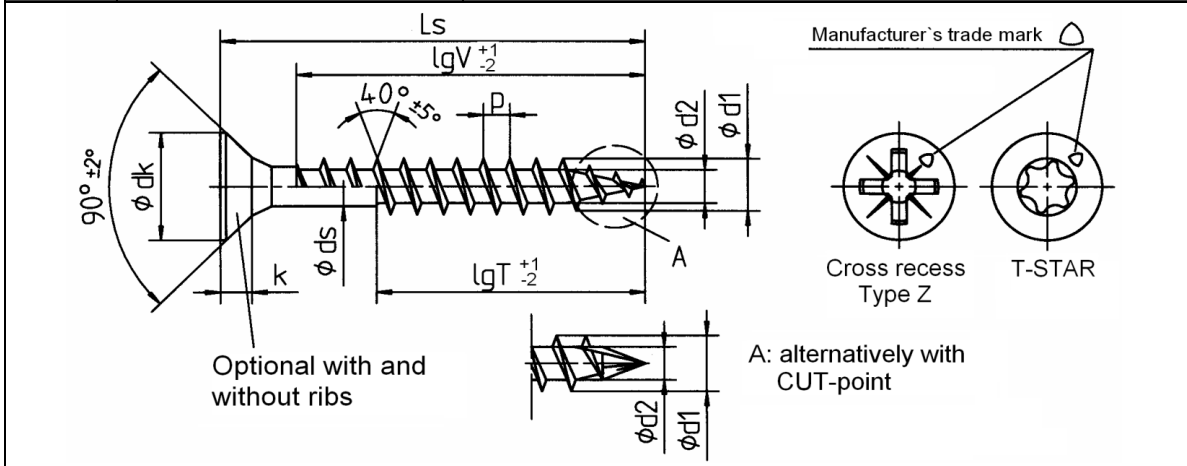

Nominal diameter	7,0						
d1	thread size	7,0					
	permissible tolerance	±0,20					
dk	head diameter	13,1					
	permissible tolerance	-0,60					
d2	core diameter	4,5					
	permissible tolerance	-0,30					
ds	shank diameter	4,90					
	permissible tolerance	±0,10					
k	head height max.	3,8					
p	thread pitch	3,5					
	permissible tolerance	±0,1 x p					
T-STAR	size	T30					
Cross recess size	Type Z	3					

Ls			Standard thread lengths (full thread = lgV / partial thread = lgT)					
Nom.dim.	min	max	lgV	lgT				
40	38,5	41,0	33,0					
45	43,5	46,0	38,0					
50	48,5	51,0	43,0	33,0				
55	53,5	56,0	48,0	33,0				
60	58,5	61,0	53,0	38,0				
65	63,5	66,0	58,0	38,0				
70	68,5	71,0	61,0	43,0				
75	73,5	76,0	68,0	43,0				
80	78,5	81,0	68,0	48,0				
90	88,5	91,5	68,0	53,0				
100	98,5	101,5	68,0	58,0				
110	108,5	111,5	68,0					
120	118,5	121,5	68,0					
130	128,0	132,0	68,0					
140	138,0	142,0	68,0					
150	148,0	152,0	68,0					
160	158,0	162,0	68,0					
180	178,0	182,0	68,0					
200	198,0	202,0	68,0					
<i>bis</i>								
400	397,0	402,0	68,0					

Lengths over 200mm to 400mm in steps of 20mm
 Intermediate lengths on Ls possible

Other thread lengths in the range ≥4xd1 to max. standard length permitted.

	SPAX®-S Washer head	Self-drilling screw with full and partial thread Material: cold rolled wire according to SPAX - Factory Standard Screws of high carbon steel
---	-------------------------------	--

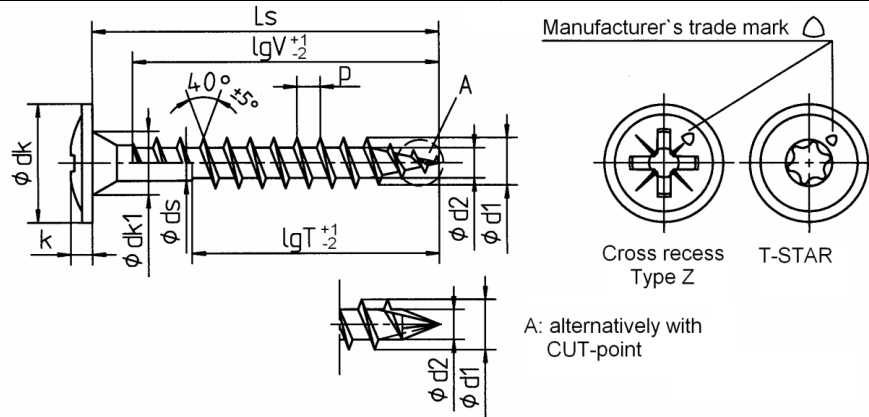



Nominal diameter		3,0	3,5	4,0	4,5	5,0	6,0
d1	thread size	3,0	3,5	4,0	4,5	5,0	6,0
	permissible tolerance	±0,15					
dk	head diameter	7,9	8,6	9,6	10,6	11,6	13,6
	permissible tolerance	-0,40	-0,50		-0,60		
dk1	contersink diameter	4,9	4,9	5,0	5,4	5,9	6,9
	permissible tolerance	+0,20					
d2	core diameter	2,0	2,2	2,5	2,8	3,1	3,8
	permissible tolerance	-0,25				-0,30	
ds	shank diameter	2,15	2,45	2,85	3,20	3,55	4,30
	permissible tolerance	±0,10					
k	head height max.	1,5	1,8	1,9	2,0	2,2	2,4
p	thread pitch	1,5	1,8	2,0	2,2	2,5	3,0
	permissible tolerance	±0,1 x p					
T- STAR	size	T10	T15	T20		T25	T30
Cross recess	size Type Z	2					

Ls			Standard thread lengths (full thread = lgV / partial thread = lgT)													
			Nom.dim.	min	max	lgV	lgT	lgV	lgT	lgV	lgT	lgV	lgT	lgV	lgT	lgV
15	14,0	15,5	13,0													
16	16,0	17,5	15,0		15,0											
20	18,5	20,5	18,0	12,5	18,0			18,0								
25	23,5	25,5	23,0	18,0	23,0	18,0		23,0	17,0	22,5		22,0				
30	28,5	30,5	28,0	18,0	27,0	18,0		27,5	18,0	27,5		27,0		27,0		
35	33,5	36,0	33,0	23,0	32,0	23,0		32,5	23,0	32,5	25,0	32,0	25,0	32,0	32,0	24,0
40	38,5	41,0	36,0	23,0	37,0	23,0		37,5	23,0	37,0	25,0	37,0	27,0	37,0	37,0	24,0
45	43,5	46,0		28,0	40,0	30,0		42,5	30,0	42,0	30,0	41,0	30,0	41,0	30,0	29,0
50	48,5	51,0		28,0		32,0		47,5	32,5	47,0	32,5	46,0	32,0	46,0	32,0	32,0
55	53,5	56,0		36,0		35,0		50,0	35,0	52,0	37,0	51,0	37,0	51,0	37,0	37,0
60	58,5	61,0				35,0		50,0	35,0	57,0	37,0	56,0	37,0	56,0	37,0	37,0
65	63,5	66,0				40,0			37,5	59,0	42,0	61,0	41,0	61,0	41,0	41,0
70	68,5	71,0							37,5	59,0	42,0	61,0	41,0	61,0	41,0	41,0
75	73,5	76,0							37,5		42,0	61,0	41,0	61,0	41,0	41,0
80	78,5	81,0							37,5		47,0	61,0	46,0	61,0	46,0	46,0
90	88,5	91,5									47,0		61,0		61,0	61,0
100	98,5	101,5											61,0		61,0	61,0
110	108,5	111,5											69,0		68,0	68,0
120	118,5	121,5											69,0		68,0	68,0
130	128,0	132,0													68,0	68,0
140	138,0	142,0													68,0	68,0
150	148,0	152,0													68,0	68,0
160	158,0	162,0													68,0	68,0

Screws of Ø6,0mm with partial thread additionally in length of 180 to 300mm, in steps of 20mm, LgT= 68,0 mm

Other thread lengths in the range ≥4xd1 to max. standard length permitted.

Intermediate lengths on Ls possible

	 Washer head	Self-drilling screw with full and partial thread Material: cold rolled wire according to SPAX - Factory Standard Screws of high carbon steel
---	--	--

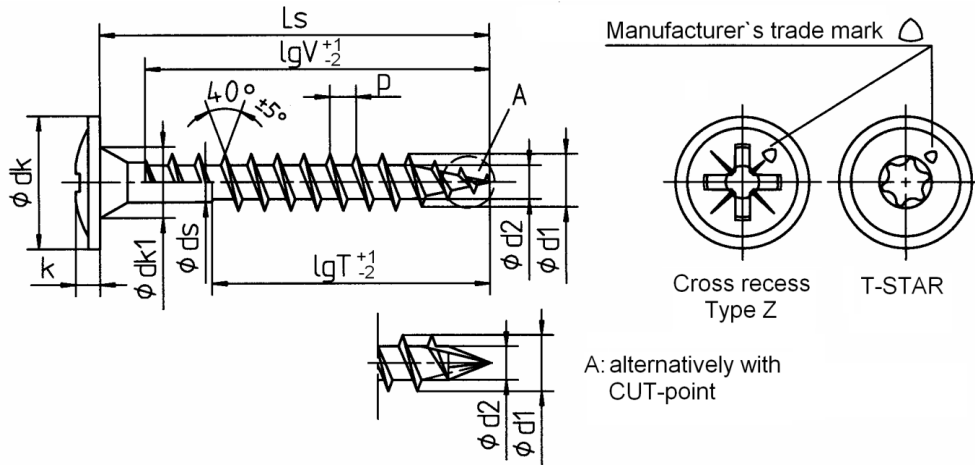



Norminal diameter	7,0								
d1	thread size	7,0							
	permissible tolerance	±0,20							
dk	head diameter	18,0							
	permissible tolerance	-0,60							
dk1	contersink diameter	7,8							
	permissible tolerance	-0,30							
d2	core diameter	4,5							
	permissible tolerance	-0,30							
ds	shank diameter	4,90							
	permissible tolerance	±0,1							
k	head height max.	3,7							
p	thread pitch	3,5							
	permissible tolerance	±0,1 x p							
T - STAR	size	T30							
Cross recess size Type Z		3							

Ls			Standard thread lengths (full thread = lgV / partial thread = lgT)																	
Nom.dim.	min	max	lgV	lgT																
50	48,5	51,0	46,0	33,0																
55	53,5	56,0	51,0	33,0																
60	58,5	61,0	56,0	38,0																
65	63,5	66,0	61,0	38,0																
70	68,5	71,0	61,0	43,0																
75	73,5	76,0	68,0	43,0																
80	78,5	81,0	68,0	48,0																
90	88,5	91,5	68,0	53,0																
100	98,5	101,5	68,0	58,0																
110	108,5	111,5		68,0																
120	118,5	121,5		68,0																
130	128,0	132,0		68,0																
140	138,0	142,0		68,0																
150	148,0	152,0		68,0																
160	158,0	162,0		68,0																
180	178,0	182,0		68,0																
200	198,0	202,0		68,0																
<i>to</i>																				
400	397,0	402,0		68,0																

Lengths over 200mm to 400mm in steps of 20mm
 Intermediate lengths on Ls possible

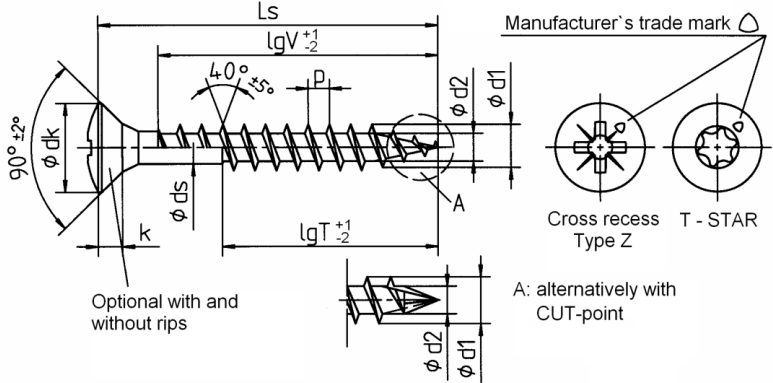
Other thread lengths in the range ≥4xd1 to max. standard length permitted.

 SPAX®-S Raised countersunk head		Self-drilling screw with full and partial thread														
		Material: cold rolled wire according to SPAX - Factory Standard Screws of high carbon steel														
																
Norminal diameter		2,5	3,0	3,5	4,0	4,5	5,0	6,0								
d1	thread size	2,5	3,0	3,5	4,0	4,5	5,0	6,0								
	permissible tolerance	±0,15														
dk	head diameter	5,1	6,0	7,0	8,0	8,8	9,7	11,6								
	permissible tolerance	-0,40														
d2	core diameter	1,7	2,0	2,2	2,5	2,8	3,1	3,8								
	permissible tolerance	-0,25						-0,30								
ds	shank diameter	1,8	2,15	2,45	2,85	3,20	3,55	4,30								
	permissible tolerance	±0,10														
k	head height max.	1,6	1,8	2,1	2,4	2,7	2,9	3,4								
p	thread pitch	1,3	1,5	1,8	2,0	2,2	2,5	3,0								
	permissible tolerance	±0,1 x p														
T - STAR size		T8 T10		T15 T20		T25		T30								
Cross recess size Type Z		1			2			3								
Ls		Standard thread lengths (full thread = lgV / partial thread = lgT)														
Nom.dim.	min	max	lgV	lgT	lgV	lgT	lgV	lgT	lgV	lgT	lgV	lgT	lgV	lgT	lgV	lgT
12	12,0	13,5	10,0													
15	14,0	15,5	12,0		12,5											
16	16,0	17,5	14,0		14,0											
20	18,5	20,5	17,0	12,0	17,0	12,5	16,0		16,0							
25	23,5	25,5	22,0	18,0	22,0	18,0	21,0	18,0	21,0		20,0		20,0			
30	28,5	30,5		18,0	26,0	18,0	25,0	18,0	25,0	18,0	25,0		25,0			24,0
35	33,5	36,0		22,0	31,0	23,0	30,0	23,0	30,0	22,5	30,0	25,0	30,0	25,0	29,0	
40	38,5	41,0		22,0	36,0	23,0	35,0	23,0	35,0	22,5	34,0	25,0	35,0	27,0	34,0	24,0
45	43,5	46,0		28,0		28,0	40,0	30,0	40,0	30,0	39,0	30,0	39,0	30,0	38,0	29,0
50	48,5	51,0				28,0	40,0	32,0	45,0	32,0	44,0	32,0	44,0	32,0	43,0	32,0
55	53,5	56,0				36,0		35,0	50,0	35,0	49,0	37,0	49,0	37,0	48,0	37,0
60	58,5	61,0						35,0	50,0	35,0	54,0	37,0	54,0	37,0	53,0	37,0
65	63,5	66,0						40,0		37,5	59,0	42,0	59,0	41,0	58,0	41,0
70	68,5	71,0								37,5	59,0	42,0	61,0	41,0	61,0	41,0
75	73,5	76,0								37,5		42,0	61,0	41,0	61,0	41,0
80	78,5	81,0								37,5		47,0	61,0	46,0	61,0	46,0
90	88,5	91,5									47,0		61,0		61,0	
100	98,5	101,5											61,0		61,0	
110	108,5	111,5											69,0		68,0	
120	118,5	121,5											69,0		68,0	
130	128,0	132,0													68,0	
140	138,0	142,0													68,0	
150	148,0	152,0													68,0	
160	158,0	162,0													68,0	
Screws of Ø6,0mm with partial thread additionally in length of 180 to 300mm, in steps of 20mm, LgT= 68,0 mm					Other thread lengths in the range ≥4xd1 to max. standard length permitted.											
Intermediate lengths on Ls possible																
Annex A5																

	SPAX®-S Raised countersunk head	Self-drilling screw with full and partial thread Material: cold rolled wire according to SPAX - Factory Standard Screws of high carbon steel

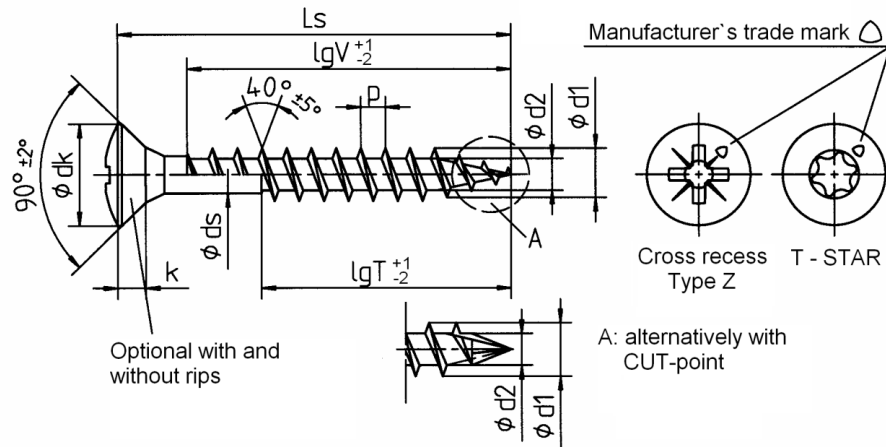



Norminal diameter	7,0								
d1	thread size	7,0							
	permissible tolerance	±0,20							
dk	head diameter	13,1							
	permissible tolerance	-0,60							
d2	core diameter	4,5							
	permissible tolerance	-0,30							
ds	shank diameter	4,90							
	permissible tolerance	±0,10							
k	head height max.	3,8							
p	thread pitch	3,5							
	permissible tolerance	±0,1 x p							
T - STAR	size	T30							
Cross recess size	Type Z	3							

Ls			Standard thread lengths (full thread = lgV / partial thread = lgT)							
Nom.dim.	min	max	lgV	lgT						
40	38,5	41,0	33,0							
45	43,5	46,0	38,0							
50	48,5	51,0	43,0	33,0						
55	53,5	56,0	48,0	33,0						
60	58,5	61,0	53,0	38,0						
65	63,5	66,0	58,0	38,0						
70	68,5	71,0	61,0	43,0						
75	73,5	76,0	68,0	43,0						
80	78,5	81,0	68,0	48,0						
90	88,5	91,5	68,0	53,0						
100	98,5	101,5	68,0	58,0						
110	108,5	111,5		68,0						
120	118,5	121,5		68,0						
130	128,0	132,0		68,0						
140	138,0	142,0		68,0						
150	148,0	152,0		68,0						
160	158,0	162,0		68,0						
180	178,0	182,0		68,0						
200	198,0	202,0		68,0						
<i>to</i>										
400	397,0	402,0		68,0						

Lenghts over 200mm to 400mm in steps of 20mm
 Intermediate lengths on Ls possible

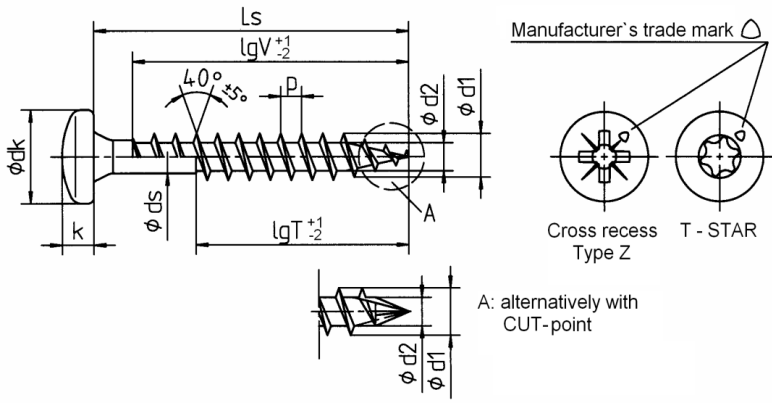
Other thread lengths in the range ≥4xd1 to max. standard length permitted.

 SPAX[®]-S Pan head		Self-drilling screw with full and partial thread																	
		Material: cold rolled wire according to SPAX - Factory Standard Screws of high carbon steel																	
																			
Nominal diameter		2,5	3,0	3,5	4,0	4,5	5,0	6,0											
d1	thread size	2,5	3,0	3,5	4,0	4,5	5,0	6,0											
	permissible tolerance	±0,15																	
dk	head diameter	5,0	6,0	7,0	8,0	9,0	9,9	11,9											
	permissible tolerance	-0,40			-0,50			-0,60											
d2	core diameter	1,7	2,0	2,2	2,5	2,8	3,1	3,8											
	permissible tolerance	-0,25					-0,30												
ds	shank diameter	1,8	2,15	2,45	2,85	3,20	3,55	4,30											
	permissible tolerance	±0,10																	
k	head height max.	2,1	2,3	2,5	2,9	3,1	3,4	4,0											
p	thread pitch	1,3	1,5	1,8	2,0	2,2	2,5	3,0											
	permissible tolerance	±0,1 x p																	
T-STAR	size	T8	T10	T15	T20		T25	T30											
Cross recess size Type Z		1			2			3											
Ls		Standard thread lengths (full thread = lgV / partial thread = lgT)																	
Nom. dim.	min	max	lgV	lgT	lgV	lgT	lgV	lgT	lgV	lgT	lgV	lgT	lgV	lgT	lgV	lgT			
12	12,0	13,5	12,0																
15	14,0	15,5	13,0		13,0														
16	16,0	17,5	15,0		15,0		15,0												
20	18,5	20,5	18,0	12,0	18,0		18,0		18,0										
25	23,5	25,5	23	18,0	23,0		23,0	18,0	23,0		22,5		22,0						
30	28,5	30,5	28,0	18,0	28,0	18,0	27,0	18,0	27,5	18,0	27,5		27,0		27,0				
35	33,5	36,0		22,0	33,0	23,0	32,0	23,0	32,5	23,0	32,5	25,0	32,0	25,0	32,0	24,0			
40	38,5	41,0		22,0	36,0	23,0	37,0	23,0	37,5	23,0	37,0	25,0	37,0	27,0	37,0	24,0			
45	43,5	46,0		28,0		28,0		30,0	42,5	30,0	42,0	30,0	41,0	30,0	41,0	29,0			
50	48,5	51,0				28,0		32,0	47,5	32,5	47,0	32,5	46,0	32,0	46,0	32,0			
55	53,5	56,0				36,0		35,0	50,0	35,0	52,0	37,0	51,0	37,0	51,0	37,0			
60	58,5	61,0						35,0	50,0	35,0	57,0	37,0	56,0	37,0	56,0	37,0			
65	63,5	66,0						40,0		37,5	59,0	42,0	61,0	41,0	60,0	41,0			
70	68,5	71,0								37,5	59,0	42,0	61,0	41,0	60,0	41,0			
75	73,5	76,0								37,5		42,0	61,0	41,0	60,0	41,0			
80	78,5	81,0								37,5		47,0	61,0	46,0	60,0	46,0			
90	88,5	91,5										47,0		61,0		61,0			
100	98,5	101,5												61,0		61,0			
110	108,5	111,5												69,0		68,0			
120	118,5	121,5												69,0		68,0			
130	128,0	132,0														68,0			
140	138,0	142,0														68,0			
150	148,0	152,0														68,0			
160	158,0	162,0														68,0			
Screws of Ø6,0mm with partial thread additionally in length of 180 to 300mm, in steps of 20mm, LgT= 68,0 mm					Other thread lengths in the range ≥4xd1 to max. standard length permitted.														
Intermediate lengths on Ls possible																			
Annex A7																			

	SPAX®-S Pan head	Self-drilling screw with full and partial thread Material: cold rolled wire according to SPAX - Factory Standard Screws of high carbon steel

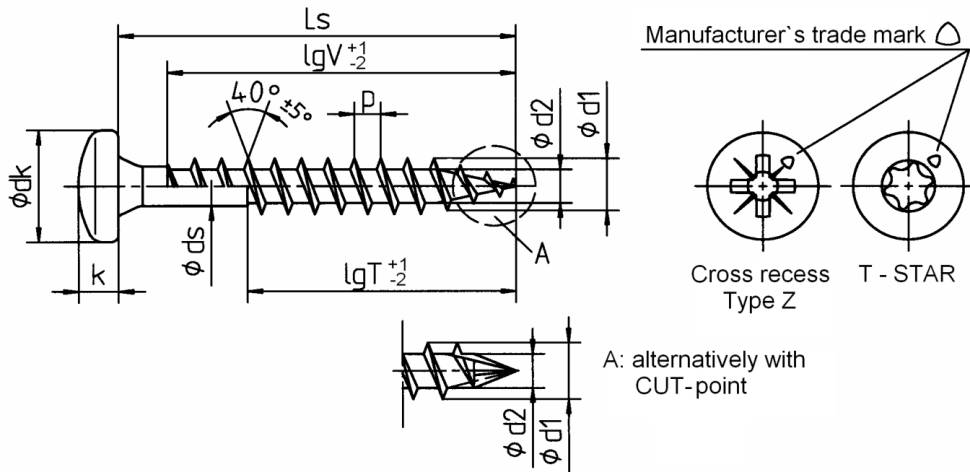



Nominal diameter		7,0												
d1	thread size	7,0												
	permissible tolerance	±0,20												
dk	head diameter	13,5												
	permissible tolerance	-0,60												
d2	core diameter	4,5												
	permissible tolerance	-0,30												
ds	shank diameter	4,90												
	permissible tolerance	±0,10												
k	head height max.	5												
p	thread pitch	3,5												
	permissible tolerance	±0,1x p												
T-STAR	size	T30												
Cross recess size Type Z		3												

Ls			Standard thread lengths (full thread = lgV / partial thread = lgT)											
Nom.dim.	min	max	lgV	lgT										
50	48,5	51,0	46,0	33,0										
55	53,5	56,0	51,0	33,0										
60	58,5	61,0	56,0	38,0										
65	63,5	66,0	61,0	38,0										
70	68,5	71,0	61,0	43,0										
75	73,5	76,0	68,0	43,0										
80	78,5	81,0	68,0	48,0										
90	88,5	91,5	68,0	53,0										
100	98,5	101,5	68,0	58,0										
110	108,5	111,5		68,0										
120	118,5	121,5		68,0										
130	128,0	132,0		68,0										
140	138,0	142,0		68,0										
150	148,0	152,0		68,0										
160	158,0	162,0		68,0										
180	178,0	182,0		68,0										
200	198,0	202,0		68,0										
<i>to</i>														
400	397,0	402,0		68,0										

Screws of Ø6,0mm with partial thread additionally in length of 180 to 300mm, in steps of 20mm, LgT= 68,0 mm
 Intermediate lengths on Ls possible

Other thread lengths in the range ≥4xd1 to max. standard length permitted.

		Self-drilling screw with double thread
	Countersunk head with cutting ribs	Material: cold rolled wire according to SPAX - Factory standard Screws of high carbon steel

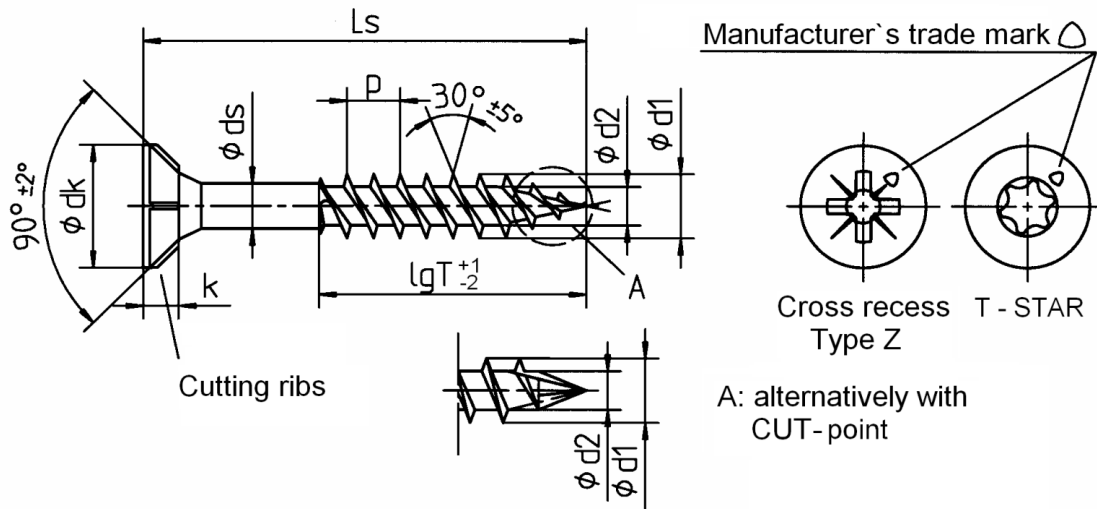



Norminal diameter					4,0	4,5		
d1	thread size				4,0	4,5		
	permissible tolerance				±0,15			
dk	head diameter				8,0	8,8		
	permissible tolerance				-0,40			
d2	core diameter				2,5	2,8		
	permissible tolerance				-0,25			
ds	shank diameter				2,85	3,20		
	permissible tolerance				±0,10			
k	head height max.				2,4	2,7		
p	thead pitch				3,3	3,5		
	permissible tolerance				±0,1 x p			
T - STAR	size				T20			
Cross recess	size Type Z				2			
Ls		Standard thread lengths (partial thread = lgT)						
Nom.dim.	min	max			lgT	lgT		
35	33,5	36,0			22,5	24,0		
40	38,5	41,0			22,5	24,0		
45	43,5	46,0			30,0	29,0		
50	48,5	51,0			30,0	29,0		
55	53,5	56,0			35,0	34,0		
60	58,5	61,0			35,0	34,0		
65	63,5	66,0			37,5	42,0		
70	68,5	71,0			37,5	42,0		
75	73,5	76,0			50,0	49,0		
80	78,5	81,0				49,0		
90	88,5	91,5				49,0		

Intermediate lengths on Ls possible

Other thread lengths in the range ≥4xd1 to max. standard length permitted

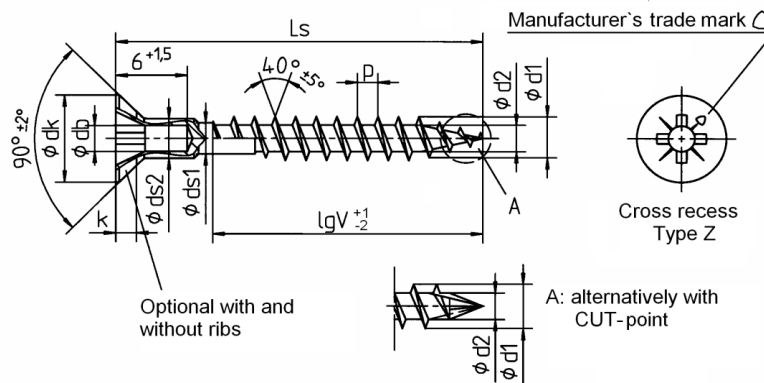
Annex A9

 SPAX®-S Countersunk with head hole		Self-drilling screw with full thread					
		Material: cold rolled wire according to SPAX - Factory Standard Screws of high carbon steel					
							
Nominal diameter				4,0	4,5	5,0	6,0
d1	thread size			4,0	4,5	5,0	6,0
	permissible tolerance			± 0,15			
dk	head diameter			8,0	8,8	9,7	11,6
	permissible tolerance			-0,50			
db	hole diameter			2,50			
	permissible tolerance			± 0,15			
d2	core diameter			2,5	2,8	3,1	3,8
	permissible tolerance			-0,25		-0,30	
ds1	shank diameter			2,85	3,20	3,55	4,30
	permissible tolerance			± 0,10			
ds2	shank diameter			3,60	3,80	4,50	ohne
	permissible tolerance			± 0,10			
k	head height max.			2,4	2,7	2,9	3,4
p	thread pitch			2,0	2,2	2,5	3,0
	permissible tolerance			± 0,1 x p			
Cross recess size Z				2		3	
Ls		Standard thread lengths (full thread = lgV)					
Nom.dim.	min	max		lgV	lgV	lgV	lgV
25	23,5	26,0		18,0			
30	28,5	31,0		23,0	20,0		
35	33,5	36,0		27,5	25,0		
40	38,5	41,0		32,5	30,0	30,0	
45	43,5	46,0		37,5	34,0	35,0	
50	48,5	51,0		42,5	39,0	39,0	41,0
55	53,5	56,0		47,5	44,0	44,0	46,0
60	58,5	61,0		50,0	49,0	49,0	51,0
65	63,5	66,0			54,0	54,0	56,0
70	68,5	71,0			59,0	61,0	61,0
75	73,5	76,0			59,0	61,0	61,0
80	78,5	81,0			59,0	61,0	61,0
90	88,5	91,5			59,0	61,0	61,0
100	98,5	101,5				61,0	61,0
110	108,5	111,5				69,0	68,0
120	118,5	121,5				69,0	68,0
130	128,0	132,0					68,0
140	138,0	142,0					68,0
150	148,0	152,0					68,0
160	158,0	162,0					68,0
Screw of Ø 6,0 mm with partial thread additionally in lengths of 180 to 300 mm , in steps of 20mm, lgV = 68,0 mm				Other thread lengths in the range ≥ 4x d1 to max. standard length permitted			
Intermediate lengths on Ls possible							
Annex A10							

	SPAX®-S Flat countersunk head	Self-drilling screw with full and partial thread Material: cold rolled wire according to SPAX - Factory Standard Stainless steel screws

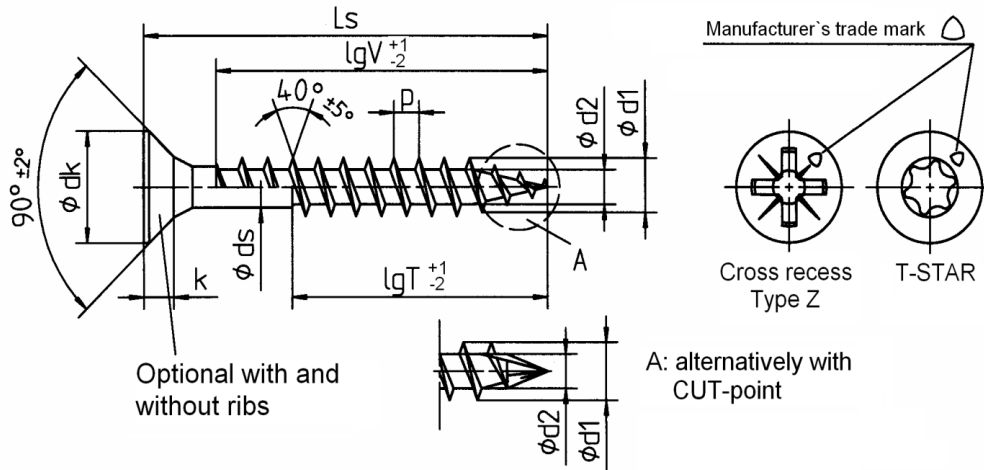

Nominal diameter		3,0	3,5	4,0	4,5	5,0	6,0	
d1	thread size	3,0	3,5	4,0	4,5	5,1	6,1	
	permissible tolerance	±0,2				±0,25		
dk	head diameter	6,0	7,0	8,0	8,8	9,7	11,6	
	permissible tolerance	-0,40						
d2	core diameter	2,1	2,4	2,8	3,0	3,4	3,8	
	permissible tolerance	-0,25				-0,30		
ds	shank diameter	2,25	2,60	3,00	3,30	3,75	4,30	
	permissible tolerance	±0,10						
k	head height max.	1,8	2,1	2,4	2,7	2,9	3,4	
p	thread pitch	1,5	1,8	2,0	2,2	2,5	3,0	
	permissible tolerance	±0,1 x p						
T-STAR	size	T10	T15	T20		T25	T30	
Cross recess size Type Z		1	2				3	

Ls			Standard thread lengths (full thread = lgV / partial thread = lgT)													
			Nom.dim.	min	max	lgV	lgT	lgV	lgT	lgV	lgT	lgV	lgT	lgV	lgT	lgV
15	14,0	15,5			12,5											
16	16,0	17,5			14,0											
20	18,5	20,5			17,0		16,0		16,0							
25	23,5	25,5			21,0	18,0	21,0	18,0	21,0		20,0		20,0			
30	28,5	30,5			26,0	18,0	25,0	18,0	25,0	18,0	25,0		25,0		24,0	
35	33,5	36,0			31,0	23,0	30,0	23,0	30,0	23,0	30,0	25,0	30,0	25,0	29,0	24,0
40	38,5	41,0			36,0	23,0	35,0	23,0	35,0	23,0	34,0	25,0	35,0	27,0	34,0	24,0
45	43,5	46,0				28,0	40,0	30,0	40,0	30,0	39,0	30,0	39,0	30,0	38,0	29,0
50	48,5	51,0				28,0	40,0	32,0	45,0	32,0	44,0	32,0	44,0	32,0	43,0	32,0
55	53,5	56,0				36,0		35,0	50,0	35,0	49,0	37,0	49,0	37,0	48,0	37,0
60	58,5	61,0						35,0	50,0	35,0	54,0	37,0	54,0	37,0	53,0	37,0
65	63,5	66,0						40,0		37,5	59,0	42,0	59,0	41,0	58,0	41,0
70	68,5	71,0								37,5	59,0	42,0	61,0	41,0	61,0	41,0
75	73,5	76,0								37,5		42,0	61,0	41,0	61,0	41,0
80	78,5	81,0								37,5		47,0	61,0	46,0	61,0	46,0
90	88,5	91,5										47,0		61,0		61,0
100	98,5	101,5												61,0		61,0
110	108,5	111,5												69,0		68,0
120	118,5	121,5												69,0		68,0
130	128,0	132,0														68,0
140	138,0	142,0														68,0
150	148,0	152,0														68,0
160	158,0	162,0														68,0

Intermediate lengths on Ls possible

Other thread lengths in the range ≥4xd1 to max. standard length permitted.

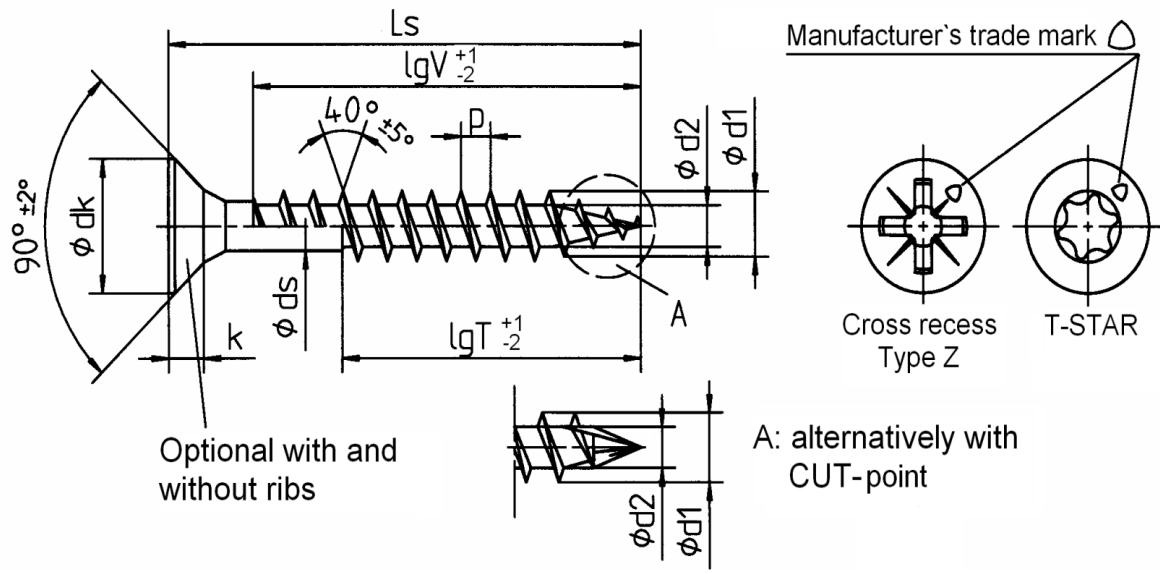

	SPAX®-S Flat countersunk head	Self-drilling screw with full and partial thread Material: cold rolled wire according to SPAX - Factory Standard Stainless steel screws



Nominal diameter	7,0								
d1	thread size	7,1							
	permissible tolerance	±0,25							
dk	head diameter	13,1							
	permissible tolerance	-0,60							
d2	core diameter	4,5							
	permissible tolerance	-0,30							
ds	shank diameter	4,90							
	permissible tolerance	±0,10							
k	head height max.	3,8							
p	thread pitch	3,5							
	permissible tolerance	±0,1 x p							
T - STAR	size	T30							
Cross recess	size Type Z	3							

Ls			Standard thread lengths (full thread = lgV / partial thread = lgT)						
Nom.dim.	min	max	lgV	lgT					
40	38,5	41,0	33,0						
45	43,5	46,0	38,0						
50	48,5	51,0	43,0	33,0					
55	53,5	56,0	48,0	33,0					
60	58,5	61,0	53,0	38,0					
65	63,5	66,0	58,0	38,0					
70	68,5	71,0	61,0	43,0					
75	73,5	76,0	68,0	43,0					
80	78,5	81,0	68,0	48,0					
90	88,5	91,5	68,0	53,0					
100	98,5	101,5	68,0	58,0					
110	108,5	111,5		68,0					
120	118,5	121,5		68,0					

Intermediate lengths on Ls possible Other thread lengths in the range ≥4xd1 to max. standard length permitted.

	 Washer head	Self-drilling screw with full and partial thread
		Material: cold rolled wire according to SPAX - Factory Standard Stainless steel screws

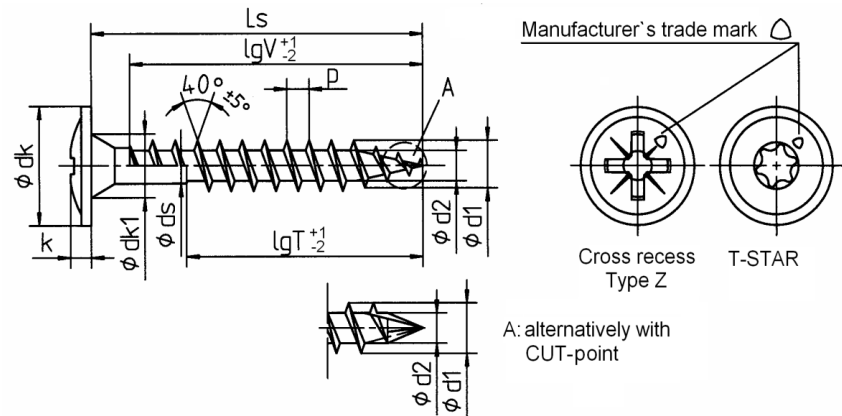

Nominal diameter		3,0	3,5	4,0	4,5	5,0	6,0
d1	thread size	3,0	3,5	4,0	4,5	5,1	6,1
	permissible tolerance	±0,20				±0,25	
dk	head diameter	7,9	8,6	9,6	10,6	11,6	13,6
	permissible tolerance	-0,40	-0,50		-0,60		
dk1	contersink diameter	4,9	4,9	5,0	5,4	5,9	6,9
	permissible tolerance	+0,20					
d2	core diameter	2,1	2,4	2,8	3,0	3,4	3,8
	permissible tolerance	-0,25				-0,30	
ds	shank diameter	2,25	2,60	3,00	3,30	3,75	4,30
	permissible tolerance	±0,10					
k	head height max.	1,5	1,8	1,9	2,0	2,2	2,4
p	thread pitch	1,5	1,8	2,0	2,2	2,5	3,0
	permissible tolerance	±0,1 x p					
T- STAR	size	T10	T15	T20		T25	T30
Cross recess size Type Z		2					

Ls			Standard thread lengths (full thread = lgV / partial thread = lgT)											
			Nom.dim.	min	max	lgV	lgT	lgV	lgT	lgV	lgT	lgV	lgT	lgV
12	12,0	13,5	13,0											
15	16,0	17,5	14,0											
16	16,0	17,5	15,0		15,0									
20	18,5	20,5	18,0	12,5	18,0		18,0							
25	23,5	25,5	23,0	18,0	23,0	18,0	23,0		22,5		22,0			
30	28,5	30,5	28,0	18,0	27,0	18,0	27,5	18,0	27,5		27,0		27,0	
35	33,5	36,0	33,0	23,0	32,0	23,0	32,5	23,0	32,5	25,0	32,0	25,0	32,0	24,0
40	38,5	41,0	36,0	23,0	37,0	23,0	37,5	23,0	37,0	25,0	37,0	27,0	37,0	24,0
45	43,5	46,0		28,0		30,0	42,5	30,0	42,0	30,0	41,0	30,0	41,0	29,0
50	48,5	51,0		28,0		32,0	47,5	32,5	47,0	32,5	46,0	32,0	46,0	32,0
55	53,5	56,0		36,0		35,0	50,0	35,0	52,0	37,0	51,0	37,0	51,0	37,0
60	58,5	61,0				35,0	50,0	35,0	57,0	37,0	56,0	37,0	56,0	37,0
65	63,5	66,0				40,0			37,5	59,0	42,0	61,0	41,0	61,0
70	68,5	71,0							37,5	59,0	42,0	61,0	41,0	61,0
75	73,5	76,0							37,5		42,0	61,0	41,0	61,0
80	78,5	81,0							37,5		47,0	61,0	46,0	61,0
90	88,5	91,5								47,0		61,0		61,0
100	98,5	101,5										61,0		61,0
110	108,5	111,5										69,0		68,0
120	118,5	121,5										69,0		68,0
130	128,5	131,5												68,0
140	138,5	141,5												68,0
150	148,5	151,5												68,0
160	158,5	161,5												68,0

Intermediate lengths on Ls possible Other thread lengths in the range ≥4xd1 to max. standard length permitted.

Annex A13

	SPAX®-S Washer head	Self-drilling screw with full and partial thread
		Material: cold rolled wire according to SPAX - Factory Standard Stainless steel screw

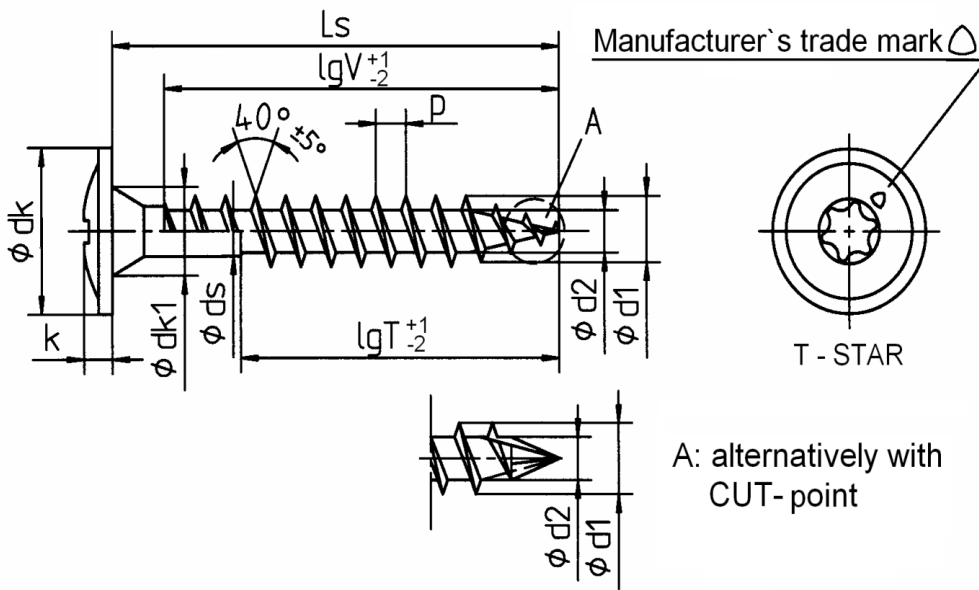

Norminal diameter	7,0																			
d1	thread size	7,1																		
	permissible tolerance	±0,25																		
dk	head diameter	18,0																		
	permissible tolerance	-0,60																		
dk1	contersink diameter	7,8																		
	permissible tolerance	-0,30																		
d2	core diameter	4,5																		
	permissible tolerance	-0,30																		
ds	shank diameter	4,90																		
	permissible tolerance	±0,10																		
k	head height max.	3,7																		
p	thread pitch	3,5																		
	permissible tolerance	±0,1 x p																		
T - STAR	size	T30																		

Ls			Standard thread lengths (full thread = lgV / partial thread = lgT)																		
Nom.dim.	min	max	lgV	lgT																	
50	48,5	51,0	46,0	33,0																	
55	53,5	56,0	51,0	33,0																	
60	58,5	61,0	56,0	38,0																	
65	63,5	66,0	61,0	38,0																	
70	68,5	71,0	61,0	43,0																	
75	73,5	76,0	68,0	43,0																	
80	78,5	81,0	68,0	48,0																	
90	88,5	91,5	68,0	53,0																	
100	98,5	101,5	68,0	58,0																	
110	108,5	111,5		68,0																	
120	118,5	121,5		68,0																	

Intermediate lengths on Ls possible

Other thread lengths in the range ≥4xd1 to max. standard length permitted.

	SPAX®-S Raised countersunk head	Self-drilling screw with full and partial thread Material: cold rolled wire according to SPAX - Factory Standard Stainless steel screws

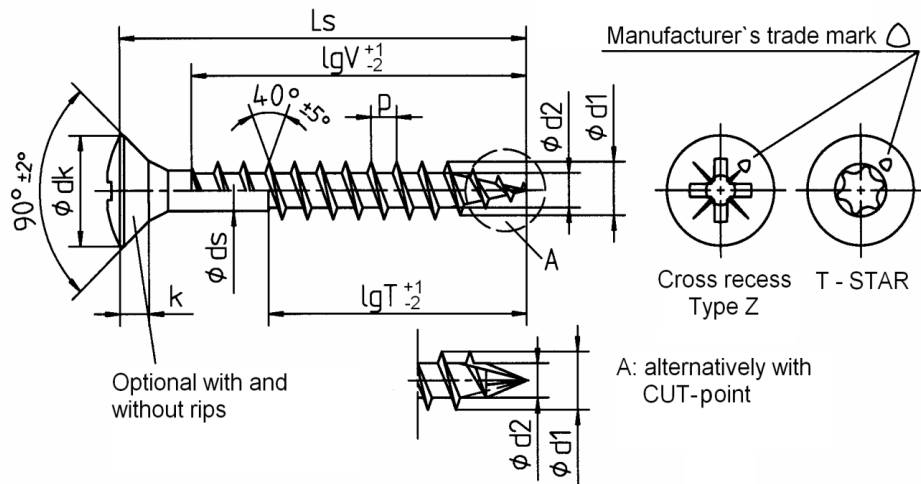

Nominal diameter		3,0	3,5	4,0	4,5	5,0	6,0								
d1	thread size	3,0	3,5	4,0	4,5	5,1	6,1								
	permissible tolerance	±0,20				±0,25									
dk	head diameter	6,0	7,0	8,0	8,8	9,7	11,6								
	permissible tolerance	-0,40					-0,43								
d2	core diameter	2,1	2,4	2,8	3,0	3,4	3,8								
	permissible tolerance	-0,25				-0,30									
ds	shank diameter	2,25	2,60	3,00	3,30	3,75	4,30								
	permissible tolerance	±0,10													
k	head height max.	1,8	2,1	2,4	2,7	2,9	3,4								
p	thread pitch	1,5	1,8	2,0	2,2	2,5	3,0								
	permissible tolerance	±0,1 x p													
T- STAR	size	T10	T15	T20		T25	T30								
Cross recess size Type Z		1	2				3								
Ls		Standard thread lengths (full thread = lgV / partial thread = lgT)													
Nom.dim.	min	max	lgV	lgT	lgV	lgT	lgV	lgT	lgV	lgT	lgV	lgT	lgV	lgT	
15	14,0	15,5	12,5												
16	16,0	17,5	14,0												
20	18,5	20,5	17,0	12,5	16,0		16,0								
25	23,5	25,5	22,0	18,0	21,0	18,0	21,0		20,0		20,0				
30	28,5	30,5	26,0	18,0	25,0	18,0	25,0	18,0	25,0		25,0		24,0		
35	33,5	36,0	31,0	23,0	30,0	23,0	30,0	23,0	30,0	25,0	30,0	25,0	29,0	24,0	
40	38,5	41,0	36,0	23,0	35,0	23,0	35,0	23,0	34,0	25,0	35,0	27,0	34,0	24,0	
45	43,5	46,0		28,0	40,0	30,0	40,0	30,0	39,0	30,0	39,0	30,0	38,0	29,0	
50	48,5	51,0		28,0	40,0	32,0	45,0	32,5	44,0	32,5	44,0	32,0	43,0	32,0	
55	53,5	56,0		36,0		35,0	50,0	35,0	49,0	37,0	49,0	37,0	48,0	37,0	
60	58,5	61,0				35,0	50,0	35,0	54,0	37,0	54,0	37,0	53,0	37,0	
65	63,5	66,0				40,0		37,5	59,0	42,0	59,0	41,0	58,0	41,0	
70	68,5	71,0						37,5	59,0	42,0	61,0	41,0	61,0	41,0	
75	73,5	76,0						37,5		42,0	61,0	41,0	61,0	41,0	
80	78,5	81,0						37,5		47,0	61,0	46,0	61,0	46,0	
90	88,5	91,5							47,0		61,0		61,0		
100	98,5	101,5									61,0		61,0		
110	108,5	111,5									69,0		68,0		
120	118,5	121,5									69,0		68,0		
130	128,0	132,0											68,0		
140	138,0	142,0											68,0		
150	148,0	152,0											68,0		
160	158,0	162,0											68,0		

Intermediate lengths on Ls possible Other thread lengths in the range ≥4xd1 to max. standard length permitted.

	SPAX®-S Raised countersunk head	Self-drilling screw with full and partial thread Material: cold rolled wire according to SPAX - Factory Standard Stainless steel screw

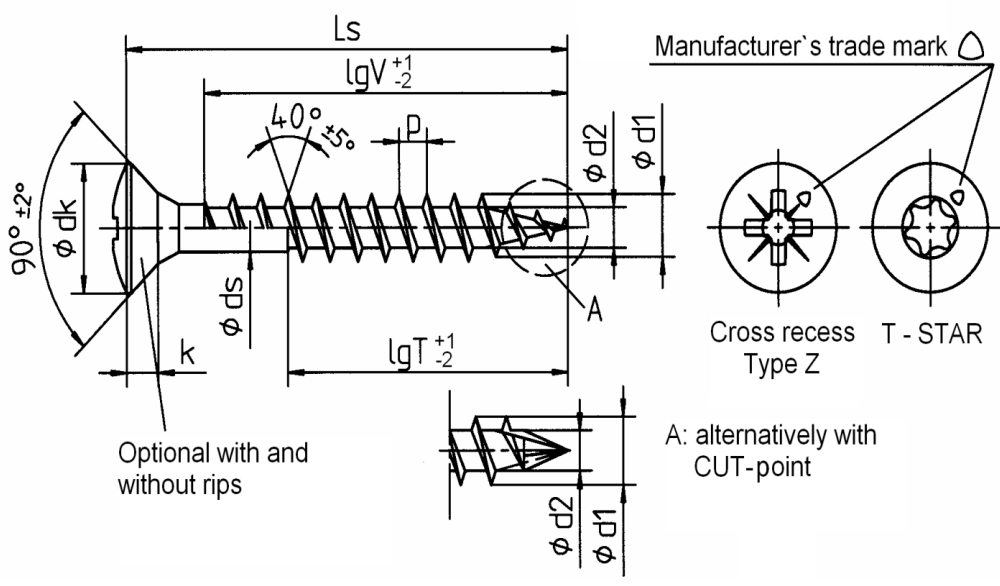

Norminal diameter	7,0																			
d1	thread size	7,1																		
	permissible tolerance	±0,25																		
dk	head diameter	13,1																		
	permissible tolerance	-0,60																		
d2	core diameter	4,5																		
	permissible tolerance	-0,30																		
ds	shank diameter	4,90																		
	permissible tolerance	±0,10																		
k	head height max.	3,8																		
p	thread pitch	3,5																		
	permissible tolerance	±0,1 x p																		
T - STAR	size	T30																		
Cross recess	size Type Z	3																		

Ls			Standard thread lengths (full thread = lgV / partial thread = lgT)																			
Nom dim.	min	max	lgV	lgT																		
40	38,5	41,0	33,0																			
45	43,5	46,0	38,0																			
50	48,5	51,0	43,0	33,0																		
55	53,5	56,0	48,0	33,0																		
60	58,5	61,0	53,0	38,0																		
65	63,5	66,0	58,0	38,0																		
70	68,5	71,0	61,0	43,0																		
75	73,5	76,0	68,0	43,0																		
80	78,5	81,0	68,0	48,0																		
90	88,5	91,5	68,0	53,0																		
100	98,5	101,5	68,0	58,0																		
110	108,5	111,5		68,0																		
120	118,5	121,5		68,0																		

Intermediate lengths on Ls possible Other thread lengths in the range ≥4xd1 to max. standard length permitted.

	SPAX®-S Pan head	Self-drilling screw with full and partial thread Material: cold rolled wire according to SPAX - Factory Standard Stainless steel screws
---	----------------------------	---

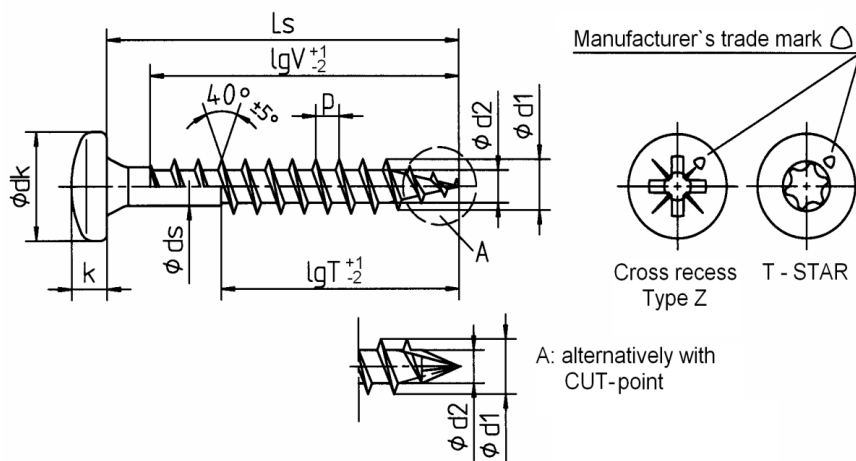

Nominal diameter			3,0	3,5	4,0	4,5	5,0	6,0						
d1	thread size		3,0	3,5	4,0	4,5	5,1	6,1						
	permissible tolerance		±0,20				±0,25							
dk	head diameter		6,0	7,0	8,0	9,0	9,9	11,9						
	permissible tolerance		-0,40			-0,50		-0,60						
d2	core diameter		2,1	2,4	2,8	3,0	3,4	3,8						
	permissible tolerance		-0,25				-0,30							
ds	shank diameter		2,25	2,60	3,00	3,30	3,75	4,30						
	permissible tolerance		±0,10											
k	head height max.		2,3	2,5	2,9	3,1	3,4	4,0						
p	thread pitch		1,5	1,8	2,0	2,2	2,5	3,0						
	permissible tolerance		±0,1 x p											
T - STAR	size		T10	T15	T20		T25	T30						
Cross recess size Type Z			1	2				3						
Ls		Standard thread lengths (full thread = lgV / partial thread = lgT)												
Nom.dim.	min	max	lgV	lgT	lgV	lgT	lgV	lgT	lgV	lgT	lgV	lgT	lgV	lgT
15	14,0	15,5	13,0											
16	16,0	17,5	15,0		15,0									
20	18,5	20,5	18,0	12,5	18,0		18,0							
25	23,5	25,5	23,0	18,0	23,0	18,0	23,0		22,5		22,0			
30	28,5	30,5	28,0	18,0	27,0	18,0	27,5	18,0	27,5		27,0		27,0	
35	33,5	36,0	33,0	23,0	32,0	23,0	32,5	23,0	32,5	25,0	32,0	25,0	32,0	24,0
40	38,5	41,0	36,0	23,0	37,0	23,0	37,5	23,0	37,0	25,0	37,0	27,0	37,0	24,0
45	43,5	46,0		28,0		30,0	42,5	30,0	42,0	30,0	41,0	30,0	41,0	29,0
50	48,5	51,0		28,0		32,0	47,5	32,5	47,0	32,5	46,0	32,0	46,0	32,0
55	53,5	56,0		36,0		35,0	50,0	35,0	52,0	37,0	51,0	37,0	51,0	37,0
60	58,5	61,0				35,0	50,0	35,0	57,0	37,0	56,0	37,0	56,0	37,0
65	63,5	66,0				40,0		37,5	59,0	42,0	61,0	41,0	60,0	41,0
70	68,5	71,0						37,5	59,0	42,0	61,0	41,0	60,0	41,0
75	73,5	76,0						37,5		42,0	61,0	41,0	60,0	41,0
80	78,5	81,0						37,5		47,0	61,0	46,0	60,0	46,0
90	88,5	91,5							47,0			61,0		61,0
100	98,5	101,5										61,0		61,0
110	108,5	111,5										69,0		68,0
120	118,5	121,5										69,0		68,0
130	128,0	132,0												68,0
140	138,0	142,0												68,0
150	148,0	152,0												68,0
160	158,0	162,0												68,0

Intermediate lengths on Ls possible Other thread lengths in the range ≥4xd1 to max. standard length permitted.

	SPAX®-S Pan head	Self-drilling screw with full and partial thread Material: cold rolled wire according to SPAX - Factory Standard Stainless steel screws
---	----------------------------	---

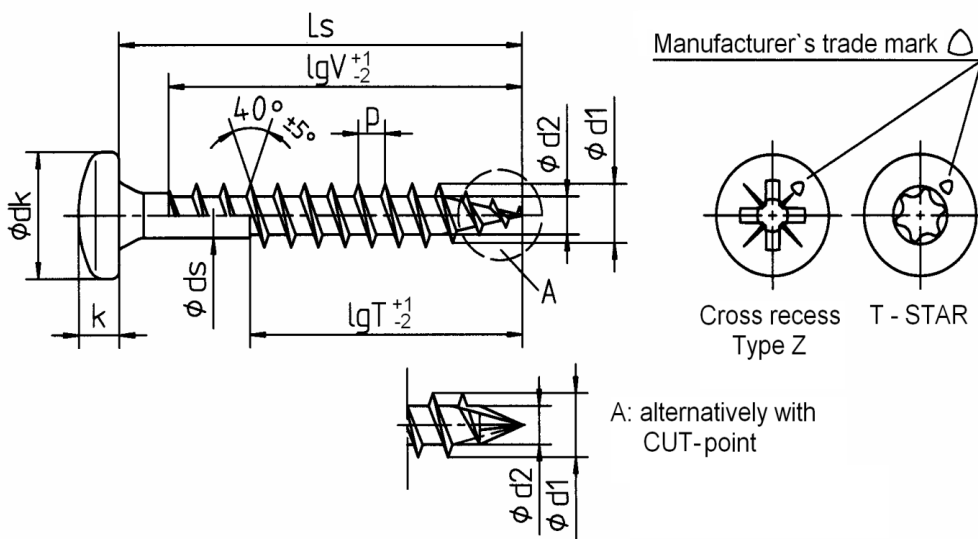

Nominal diameter	7,0								
d1	thread size	7,1							
	permissible tolerance	±0,25							
dk	head diameter	13,5							
	permissible tolerance	-0,60							
d2	core diameter	4,5							
	permissible tolerance	-0,30							
ds	shank diameter	4,90							
	permissible tolerance	±0,10							
k	head high max.	5							
p	thread pitch	3,5							
	permissible tolerance	±0,1 x p							
T - STAR	size	T30							
Cross recess	size Type Z	3							

Ls			Standard thread lengths (full thread = lgV / partial thread = lgT)							
Nom.dim.	min	max	lgV	lgT						
50	48,5	51,0	46,0	33,0						
55	53,5	56,0	51,0	33,0						
60	58,5	61,0	56,0	38,0						
65	63,5	66,0	61,0	38,0						
70	68,5	71,0	61,0	43,0						
75	73,5	76,0	68,0	43,0						
80	78,5	81,0	68,0	48,0						
90	88,5	91,5	68,0	53,0						
100	98,5	101,5	68,0	58,0						
110	108,5	111,5		68,0						
120	118,5	121,5		68,0						

Intermediate lengths on Ls possible

Other thread lengths in the range ≥4xd1 to max. standard length permitted.

	SPAX® Flat countersunk head	Self-drilling screw with full and partial thread Material: cold rolled wire according to SPAX - Factory Standard Screws of high carbon steel

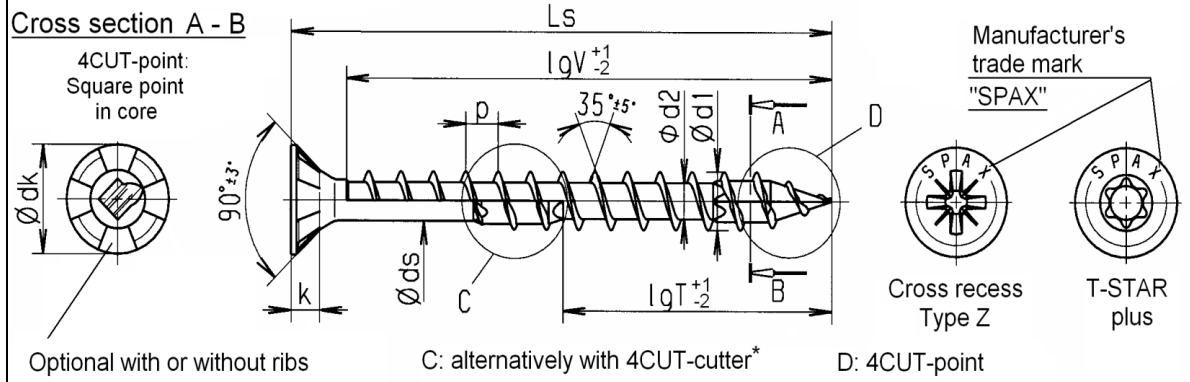



Nominal diameter				3,5	4,0	4,5	5,0	6,0
d1	thread size			3,5	4,0	4,5	5,0	6,0
	permissible tolerance			±0,20				
dk	head diameter			7,0	8,0	8,8	9,7	11,6
	permissible tolerance			-0,40		-0,50		-0,60
d2	core diameter			2,3	2,6	3,0	3,3	4,0
	permissible tolerance			-0,30		-0,40		
ds	shank diameter			2,45	2,85	3,20	3,55	4,30
	permissible tolerance			±0,10				
k	head height max.			2,1	2,4	2,7	2,9	3,4
p	thread pitch			2,1	2,4	2,7	3,0	3,6
	permissible tolerance			±0,1 x p				
T-STAR plus size				T15	T20			T30
Cross recess size Type Z				2				3

Ls			Standard thread lengths (full thread = lgV / partial thread = lgT)											
Nom.dim.	min	max	lgV	lgT	lgV	lgT	lgV	lgT	lgV	lgT	lgV	lgT	lgV	lgT
20	18,5	20,5	16,0		16,0									
25	23,5	25,5	21,0	18,0	21,0		20,0		20,0					
30	28,5	30,5	25,0	18,0	25,0	18,0	25,0		25,0				24,0	
35	33,5	36,0	30,0	23,0	30,0	23,0	30,0	25,0	30,0	25,0	29,0	24,0		
40	38,5	41,0	35,0	23,0	35,0	23,0	34,0	25,0	35,0	27,0	34,0	24,0		
45	43,5	46,0	40,0	30,0	40,0	30,0	39,0	30,0	39,0	30,0	38,0	29,0		
50	48,5	51,0	40,0	32,0	45,0	32,5	44,0	32,5	44,0	32,0	43,0	32,0		
55	53,5	56,0		35,0	50,0	35,0	49,0	37,0	49,0	37,0	48,0	37,0		
60	58,5	61,0		35,0	50,0	35,0	54,0	37,0	54,0	37,0	53,0	37,0		
65	63,5	66,0		40,0	50,0	37,5	59,0	42,0	59,0	41,0	58,0	41,0		
70	68,5	71,0			50,0	37,5	59,0	42,0	61,0	41,0	61,0	41,0		
75	73,5	76,0			50,0	37,5	59,0	42,0	61,0	41,0	61,0	41,0		
80	78,5	81,0			50,0	37,5	59,0	47,0	61,0	46,0	61,0	46,0		
90	88,5	91,5					59,0	47,0		61,0		61,0		
100	98,5	101,5								61,0		61,0		
110	108,5	111,5								69,0*		68,0*		
120	118,5	121,5								69,0*		68,0*		
130	128,0	132,0										68,0*		
140	138,0	142,0										68,0*		
150	148,0	152,0										68,0*		
160	158,0	162,0										68,0*		

Screws of Ø6,0mm with partial thread additionally in lengths of 180 to 300mm, in steps of 20mm, LgT= 68,0 mm? Other thread lengths in the range ≥4xd1 to max. standard length permitted.

Intermediate lengths on Ls possible * Design C with lgT= max. 65,0 mm

	 Washer head	Self-drilling screw with full and partial thread
		Material: cold rolled wire according to SPAX - Factory Standard Screws of high carbon steel

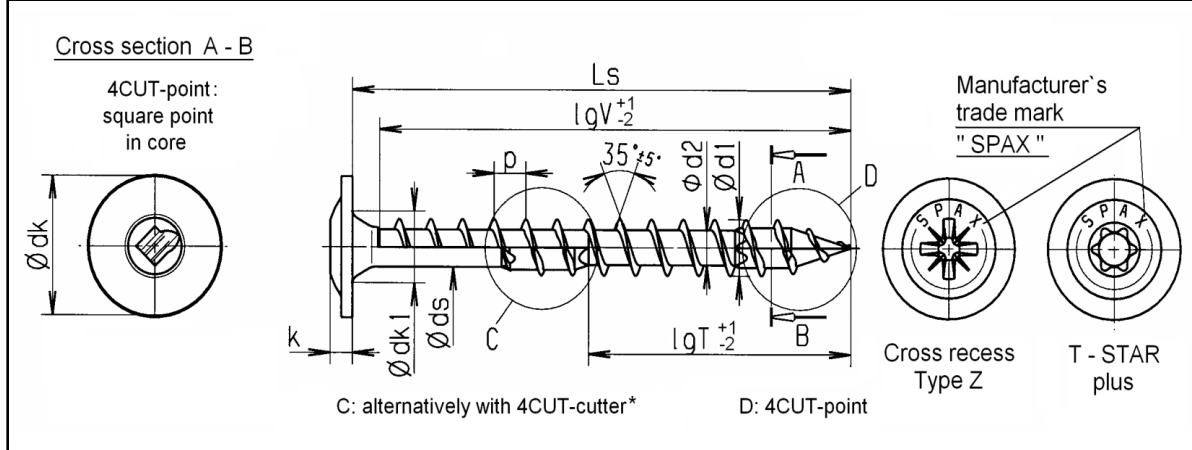



Nominal diameter			3,5	4,0	4,5	5,0	6,0
d1	thread size		3,5	4,0	4,5	5,0	6,0
	permissible tolerance		±0,20				
dk	head diameter		8,6	9,6	10,6	11,6	13,6
	permissible tolerance		-0,50				
dk1	countersink diameter		4,9	5,0	5,4	5,9	6,9
	permissible tolerance		+0,20				
d2	core diameter		2,3	2,6	3,0	3,3	4,0
	permissible tolerance		-0,30				
ds	shank diameter		2,45	2,85	3,20	3,55	4,30
	permissible tolerance		±0,10				
k	head height max.		1,8	1,9	2,0	2,2	3,1
p	thread pitch		2,1	2,4	2,7	3,0	3,6
	permissible tolerance		±0,1 x p				
T-STAR plus size			T15	T20			T30
Cross recess size Type Z			2				

Ls Nom.dim.	Standard thread lengths (full thread = lgV / partial thread = lgT)															
	min	max	lgV	lgT	lgV	lgT	lgV	lgT	lgV	lgT	lgV	lgT	lgV	lgT	lgV	lgT
16	16,0	17,5	15,0													
20	18,5	20,5	18,0		18,0											
25	23,5	25,5	23,0	18,0	23,0			22,5		22,0						
30	28,5	30,5	27,0	18,0	27,5	18,0	27,5		27,0					27,0		
35	33,5	36,0	32,0	23,0	32,5	23,0	32,5	25,0	32,0	25,0	32,0	24,0				
40	38,5	41,0	37,0	23,0	37,5	23,0	37,0	25,0	37,0	27,0	37,0	24,0				
45	43,5	46,0	40,0	30,0	42,5	30,0	42,0	30,0	41,0	30,0	41,0	29,0				
50	48,5	51,0	40,0	32,0	47,5	32,5	47,0	32,5	46,0	32,0	46,0	32,0				
55	53,5	56,0		35,0	50,0	35,0	52,0	37,0	51,0	37,0	51,0	37,0				
60	58,5	61,0		35,0	50,0	35,0	57,0	37,0	56,0	37,0	56,0	37,0				
65	63,5	66,0		40,0	50,0	37,5	59,0	42,0	61,0	41,0	61,0	41,0				
70	68,5	71,0			50,0	37,5	59,0	42,0	61,0	41,0	61,0	41,0				
75	73,5	76,0			50,0	37,5	59,0	42,0	61,0	41,0	61,0	41,0				
80	78,5	81,0					59,0	47,0	61,0	46,0	61,0	46,0				
90	88,5	91,5					59,0	47,0		61,0		61,0				
100	98,5	101,5								61,0		61,0				
110	108,5	111,5								69,0*		68,0*				
120	118,5	121,5								69,0*		68,0*				
130	128,0	132,0										68,0*				
140	138,0	142,0										68,0*				
150	148,0	152,0										68,0*				
160	158,0	162,0										68,0*				

Screws of Ø6,0mm with partial thread additionally in lengths of 180 to 300mm, in steps of 20mm, LgT= 68,0 mm?
 Intermediate lengths on Ls possible

Other thread lengths in the range ≥4xd1 to max. standard length permitted.
 * Design C with LgT= max. 65,0 mm

Annex A20

		Self-drilling screw with full and partial thread
	Raised countersunk head	Material: cold rolled wire according to SPAX - Factory Standard Screws of high carbon steel

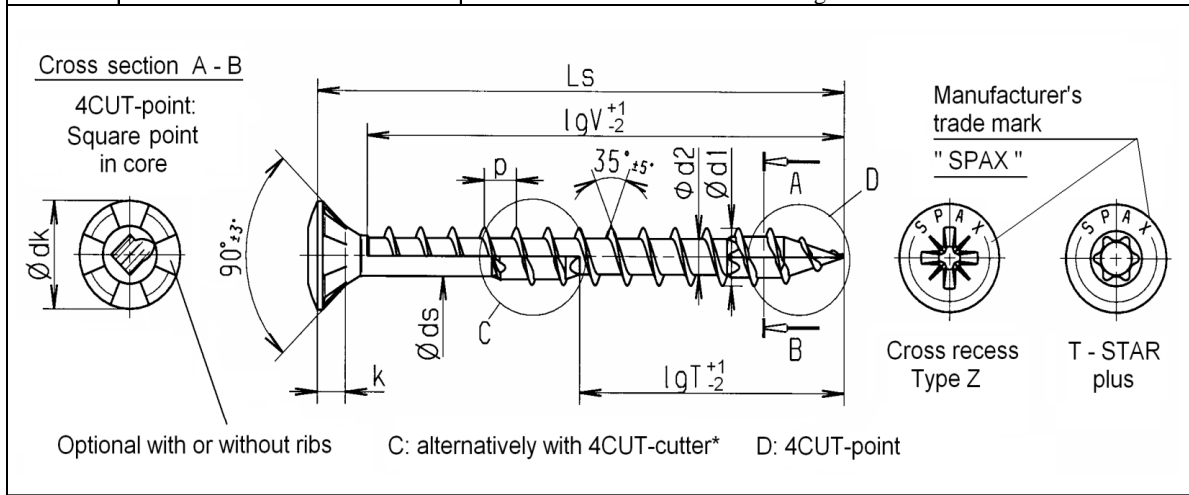



Nominal diameter			3,5	4,0	4,5	5,0	6,0
d1	thread size		3,5	4,0	4,5	5,0	6,0
	permissible tolerance		±0,20				
dk	head diameter		7,0	8,0	8,8	9,7	11,6
	permissible tolerance		-0,40		-0,50		
d2	core diameter		2,3	2,6	3,0	3,3	4,0
	permissible tolerance		-0,30		-0,40		
ds	shank diameter		2,45	2,85	3,20	3,55	4,30
	permissible tolerance		±0,10				
k	head height max.		2,1	2,4	2,7	2,9	3,4
p	thread pitch		2,1	2,4	2,7	3,0	3,6
	permissible tolerance		±0,1 x p				
T-STAR plus size			T15	T20			T30
Cross recess size Type Z			2				3

Ls Nom.dim.	Standard thread lengths (full thread = lgV / partial thread = lgT)															
	min	max	lgV	lgT	lgV	lgT	lgV	lgT	lgV	lgT	lgV	lgT	lgV	lgT	lgV	lgT
20	18,5	20,5	16,0		16,0											
25	23,5	25,5	23,0	18,0	21,0		20,0		20,0							
30	28,5	30,5	25,0	18,0	25,0	18,0	25,0		25,0				24,0			
35	33,5	36,0	30,0	23,0	30,0	23,0	30,0	25,0	30,0	25,0	29,0					
40	38,5	41,0	35,0	23,0	35,0	23,0	34,0	25,0	35,0	27,0	34,0	24,0				
45	43,5	46,0	40,0	30,0	40,0	30,0	39,0	30,0	39,0	30,0	38,0	29,0				
50	48,5	51,0	40,0	32,0	45,0	32,5	44,0	32,5	44,0	32,0	43,0	32,0				
55	53,5	56,0		35,0	50,0	35,0	49,0	37,0	49,0	37,0	48,0	37,0				
60	58,5	61,0		35,0	50,0	35,0	54,0	37,0	54,0	37,0	53,0	37,0				
65	63,5	66,0		40,0	50,0	37,5	59,0	42,0	59,0	41,0	58,0	41,0				
70	68,5	71,0			50,0	37,5	59,0	42,0	61,0	41,0	61,0	41,0				
75	73,5	76,0			50,0	37,5	59,0	42,0	61,0	41,0	61,0	41,0				
80	78,5	81,0			50,0	37,5	59,0	47,0	61,0	46,0	61,0	46,0				
90	88,5	91,5					59,0	47,0		61,0		61,0				
100	98,5	101,5								61,0		61,0				
110	108,5	111,5									69,0*		68,0*			
120	118,5	121,5									69,0*		68,0*			
130	128,0	132,0											68,0*			
140	138,0	142,0											68,0*			
150	148,0	152,0											68,0*			
160	158,0	162,0											68,0*			

Screws of Ø6,0mm with partial thread additionally in lengths of 180 to 300mm, in steps of 20mm, LgT= 68,0 mm²
 Intermediate lengths on Ls possible

Other thread lengths in the range ≥4xd1 to max. standard length permitted.
 * Design C with LgT= max. 65,0 mm

Annex A21

	 SPAX [®] Pan head	Self-drilling screw with full and partial thread Material: cold rolled wire according to SPAX - Factory Standard Screws of high carbon steel
---	---	--

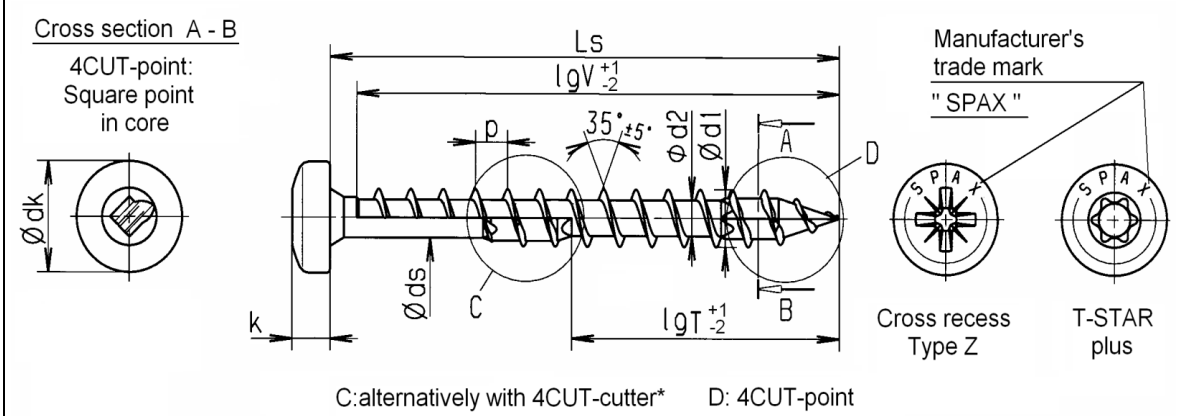

Nominal diameter				3,5	4,0	4,5	5,0	6,0
d1	thread size			3,5	4,0	4,5	5,0	6,0
	permissible tolerance			±0,20				
dk	head diameter			7,0	8,0	9,0	9,9	11,9
	permissible tolerance			-0,40		-0,50		-0,60
d2	core diameter			2,3	2,6	3,0	3,3	4,0
	permissible tolerance			-0,30		-0,40		
ds	shank diameter			2,45	2,85	3,20	3,55	4,30
	permissible tolerance			±0,10				
k	head height max.			2,5	2,9	3,1	3,4	4,0
p	thread pitch			2,1	2,4	2,7	3,0	3,6
	permissible tolerance			±0,1 x p				
T-STAR plus size				T15	T20			T30
Cross recess size Z				2				3

Ls			Standard thread lengths (full thread = lgV / partial thread = lgT)											
Nom. dim.	min	max	lgV	lgT	lgV	lgT	lgV	lgT	lgV	lgT	lgV	lgT	lgV	lgT
16	16,0	17,5	15,0											
20	18,5	20,5	18,0			18,0								
25	23,5	25,5	23,0	18,0	23,0			22,5		22,0				
30	28,5	30,5	27,0	18,0	27,5	18,0	27,0			27,0			27,0	
35	33,5	36,0	32,0	23,0	32,5	23,0	32,5	25,0	32,0	25,0	32,0	24,0		
40	38,5	41,0	37,0	23,0	37,5	23,0	37,0	25,0	37,0	27,0	37,0	24,0		
45	43,5	46,0	40,0	30,0	42,5	30,0	42,0	30,0	41,0	30,0	41,0	29,0		
50	48,5	51,0	40,0	32,0	47,5	32,5	47,0	32,5	46,0	32,0	46,0	32,0		
55	53,5	56,0		35,0	50,0	35,0	52,0	37,0	51,0	37,0	51,0	37,0		
60	58,5	61,0		35,0	50,0	35,0	57,0	37,0	56,0	37,0	56,0	37,0		
65	63,5	66,0		40,0	50,0	37,5	59,0	42,0	61,0	41,0	61,0	41,0		
70	68,5	71,0			50,0	37,5	59,0	42,0	61,0	41,0	61,0	41,0		
75	73,5	76,0			50,0	37,5	59,0	42,0	61,0	41,0	61,0	41,0		
80	78,5	81,0			50,0	37,5	59,0	47,0	61,0	46,0	61,0	46,0		
90	88,5	91,5					59,0	47,0		61,0		61,0		
100	98,5	101,5								61,0		61,0		
110	108,5	111,5								69,0*		68,0*		
120	118,5	121,5								69,0*		68,0*		
130	128,0	132,0										68,0*		
140	138,0	142,0										68,0*		
150	148,0	152,0										68,0*		
160	158,0	162,0										68,0*		

Screws of Ø6,0mm with partial thread additionally in lengths of 180 to 300mm, in steps of 20mm, LgT= 68,0 mm[†]

Intermediate lengths on Ls possible

Other thread lengths in the range ≥4xd1 to max. standard length permitted.

* Design C with lgT= max. 65,0 mm

	SPAX®	Self-drilling screw with full and partial thread
	Flat countersunk head	Material: cold rolled wire according to SPAX - Factory Standard Stainless steel screws

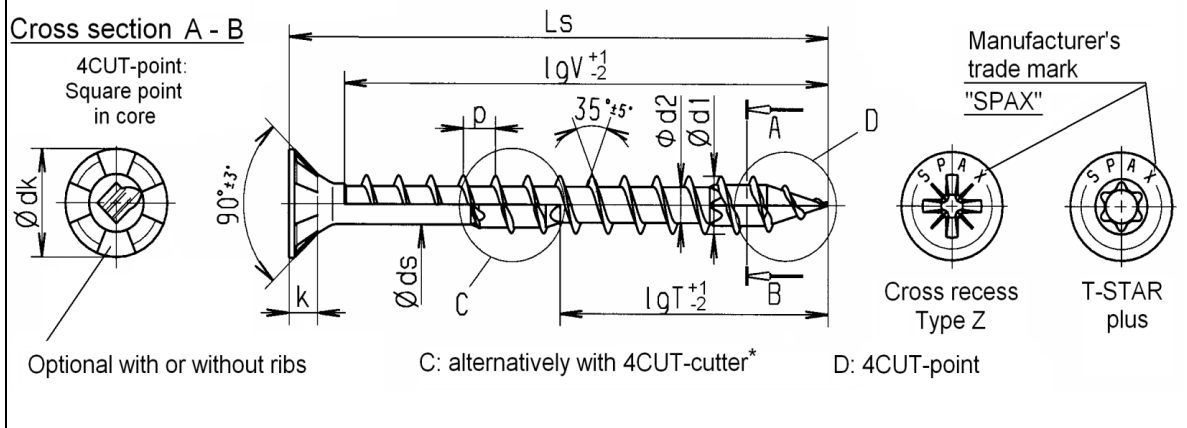



Nominal diameter				3,5	4,0	4,5	5,0	6,0
d1	thread Size			3,5	4,0	4,5	5,1	6,1
	permissible tolerance			±0,20			±0,25	
dk	head diameter			7,0	8,0	8,8	9,7	11,6
	permissible tolerance			-0,40			-0,50	
d2	core diameter			2,5	2,8	3,2	3,5	4,0
	permissible tolerance			-0,30			-0,40	
ds	shank diameter			2,60	3,00	3,30	3,75	4,30
	permissible tolerance			±0,10				
k	head height max.			2,1	2,4	2,7	2,9	3,4
p	thread pitch			2,1	2,4	2,7	3,0	3,6
	permissible tolerance			±0,1 x p				
T-STAR plus size				T15		T20		T30
Cross recess size Type Z				2				3

Ls			Standard thread lengths (full thread = lgV / partial thread = lgT)											
Nom.dim.	min	max	lgV	lgT	lgV	lgT	lgV	lgT	lgV	lgT	lgV	lgT	lgV	lgT
20	18,5	20,5	16,0		16,0									
25	23,5	25,5	21,0	18,0	21,0		20,0		20,0					
30	28,5	30,5	25,0	18,0	25,0	18,0	25,0		25,0			24,0		
35	33,5	36,0	30,0	23,0	30,0	23,0	30,0	25,0	30,0	25,0	29,0			
40	38,5	41,0	35,0	23,0	35,0	23,0	34,0	25,0	35,0	27,0	34,0	24,0		
45	43,5	46,0	40,0	30,0	40,0	30,0	39,0	30,0	39,0	30,0	38,0	29,0		
50	48,5	51,0	40,0	32,0	45,0	32,5	44,0	32,5	44,0	32,0	43,0	32,0		
55	53,5	56,0		35,0	50,0	35,0	49,0	37,0	49,0	37,0	48,0	37,0		
60	58,5	61,0		35,0	50,0	35,0	54,0	37,0	54,0	37,0	53,0	37,0		
65	63,5	66,0		40,0	50,0	37,5	59,0	42,0	59,0	41,0	58,0	41,0		
70	68,5	71,0			50,0	37,5	59,0	42,0	61,0	41,0	61,0	41,0		
75	73,5	76,0			50,0	37,5	59	42,0	61,0	41,0	61,0	41,0		
80	78,5	81,0			50,0	37,5	59,0	47,0	61,0	46,0	61,0	46,0		
90	88,5	91,5					59,0	47,0		61,0		61,0		
100	98,5	101,5								61,0		61,0		
110	108,5	111,5								69,0*		68,0*		
120	118,5	121,5								69,0*		68,0*		
130	128,0	132,0										68,0*		
140	138,0	142,0										68,0*		
150	148,0	152,0										68,0*		
160	158,0	162,0										68,0*		

Intermediate lengths on Ls possible

Other thread lengths in the range ≥4xd1 to max. standard length permitted.

* Design C with lgT= max. 65,0 mm

	 Washer head	Self-drilling screw with full and partial thread
		Material: cold rolled wire according to SPAX - Factory Standard Stainless steel screws

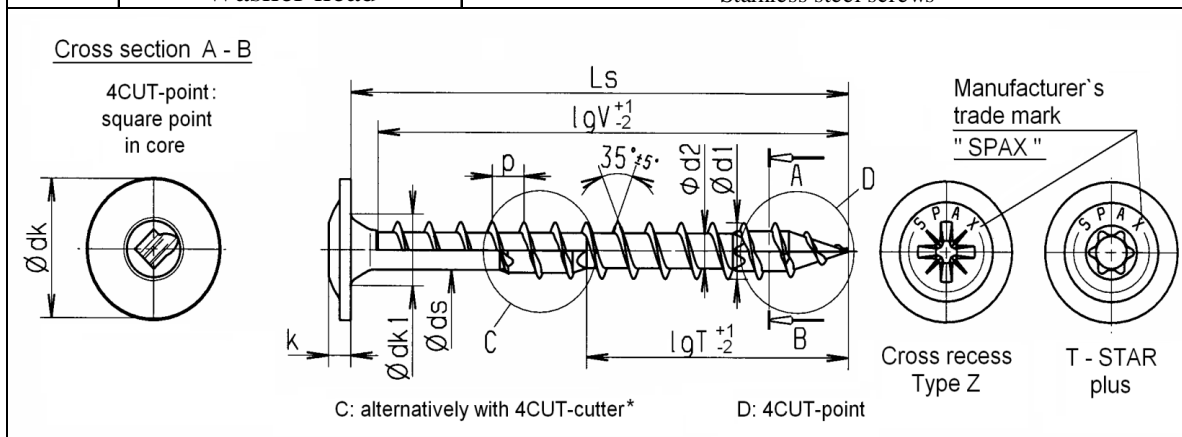

Nominal diameter		3,5	4,0	4,5	5,0	6,0
d1	thread size	3,5	4,0	4,5	5,1	6,1
	permissible tolerance	±0,20			±0,25	
dk	head diameter	8,6	9,6	10,6	11,6	13,6
	permissible tolerance	-0,50			-0,60	
dk1	countersink diameter	4,9	5,0	5,4	5,9	6,9
	permissible tolerance	+0,20				
d2	core diameter	2,5	2,8	3,2	3,5	4,0
	permissible tolerance	-0,30		-0,40		+0,1 / -0,3
ds	shank diameter	2,60	3,00	3,30	3,75	4,30
	permissible tolerance	±0,10				
k	head height max.	1,8	1,9	2,0	2,2	3,1
p	thread pitch	2,1	2,4	2,7	3,0	3,6
	permissible tolerance	±0,1 x p				
T-STAR plus size		T15	T20		T30	
Cross recess size Type Z		2				

Ls Nom.dim.	Standard thread lengths (full thread = lgV / partial thread = lgT)													
	min	max	lgV	lgT	lgV	lgT	lgV	lgT	lgV	lgT	lgV	lgT	lgV	lgT
16	16,0	17,5	15,0											
20	18,5	20,5	18,0		18,0									
25	23,5	25,5	23,0	18,0	23,0		22,5		22,0					
30	28,5	30,5	27,0	18,0	27,5	18,0	27,5		27,0			27,0		
35	33,5	36,0	32,0	23,0	32,5	23,0	32,5	25,0	32,0	25,0	32,0	24,0		
40	38,5	41,0	37,0	23,0	37,5	23,0	37,0	25,0	37,0	27,0	37,0	24,0		
45	43,5	46,0	40,0	30,0	42,5	30,0	42,0	30,0	41,0	30,0	41,0	29,0		
50	48,5	51,0	40,0	32,0	47,5	32,5	47,0	32,5	46,0	32,0	46,0	32,0		
55	53,5	56,0		35,0	50,0	35,0	52,0	37,0	51,0	37,0	51,0	37,0		
60	58,5	61,0		35,0	50,0	35,0	57,0	37,0	56,0	37,0	56,0	37,0		
65	63,5	66,0		40,0	50,0	37,5	59,0	42,0	61,0	41,0	61,0	41,0		
70	68,5	71,0			50,0	37,5	59,0	42,0	61,0	41,0	61,0	41,0		
75	73,5	76,0			50,0	37,5	59,0	42,0	61,0	41,0	61,0	41,0		
80	78,5	81,0					59,0	47,0	61,0	46,0	61,0	46,0		
90	88,5	91,5						59,0	47,0		61,0	61,0		
100	98,5	101,5									61,0	61,0		
110	108,5	111,5									69,0*	68,0*		
120	118,5	121,5									69,0*	68,0*		
130	128,0	132,0										68,0*		
140	138,0	142,0										68,0*		
150	148,0	152,0										68,0*		
160	158,0	162,0										68,0*		

Intermediate lengths on Ls possible

Other thread lengths in the range ≥4xd1 to max. standard length permitted.
* Design C with lgT= max. 65,0 mm

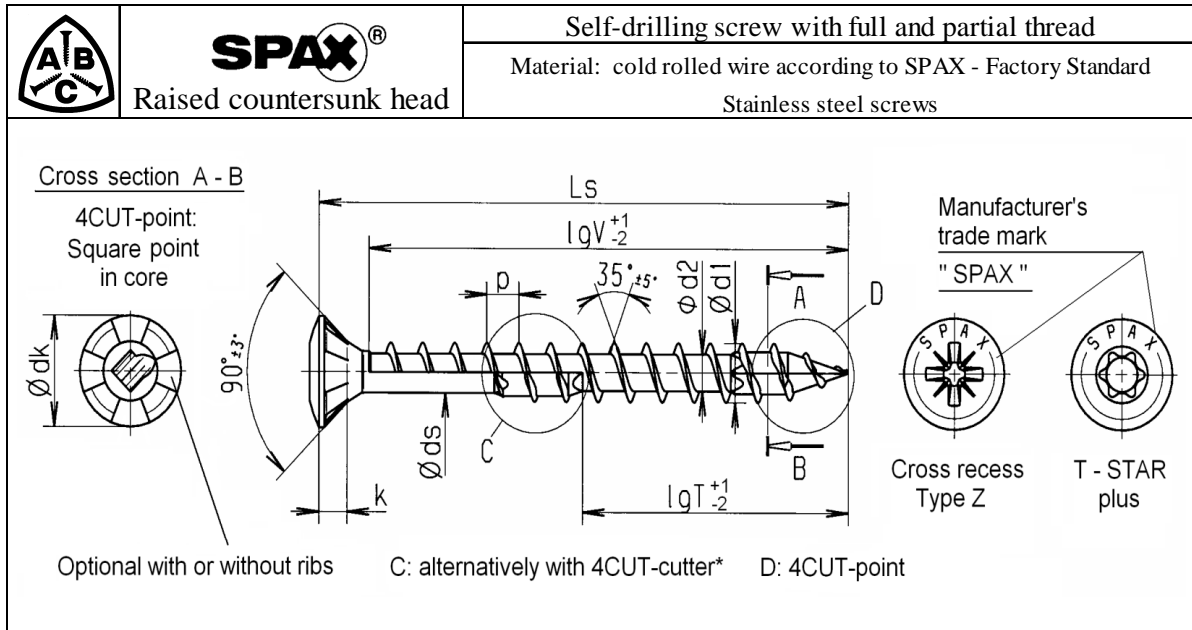



Nominal diameter		3,5	4,0	4,5	5,0	6,0
d1	thread size	3,5	4,0	4,5	5,1	6,1
	permissible tolerance	±0,20			±0,25	
dk	head diameter	7,0	8,0	8,8	9,7	11,6
	permissible tolerance	-0,40		-0,50		
d2	core diameter	2,5	2,8	3,2	3,5	4,0
	permissible tolerance	-0,30		-0,40		+0,1 / -0,3
ds	shank diameter	2,60	3,00	3,30	3,75	4,30
	permissible tolerance	±0,10				
k	head height max.	2,1	2,4	2,7	2,9	3,4
p	thread pitch	2,1	2,4	2,7	3,0	3,6
	permissible tolerance	±0,1 x p				
T-STAR plus size		T15		T20		T30
Cross recess size Type Z		2				3

Ls			Standard thread lengths (full thread = lgV / partial thread = lgT)											
Nom.dim.	min	max	lgV	lgT	lgV	lgT	lgV	lgT	lgV	lgT	lgV	lgT	lgV	lgT
20	18,5	20,5	16,0	16,0										
25	23,5	25,5	21,0	18,0	21,0		20,0		20,0					
30	28,5	30,5	25,0	18,0	25,0	18,0	25,0		25,0				24,0	
35	33,5	36,0	30,0	23,0	30,0	23,0	30,0	25,0	30,0	25,0	30,0	25,0	29,0	
40	38,5	41,0	35,0	23,0	35,0	23,0	34,0	25,0	35,0	27,0	34,0	24,0		
45	43,5	46,0		30,0	40,0	30,0	39,0	30,0	39,0	30,0	38,0	29,0		
50	48,5	51,0		32,0	45,0	32,5	44,0	32,5	44,0	32,0	43,0	32,0		
55	53,5	56,0		35,0	50,0	35,0	49,0	37,0	49,0	37,0	48,0	37,0		
60	58,5	61,0		35,0	50,0	35,0	54,0	37,0	54,0	37,0	53,0	37,0		
65	63,5	66,0		40,0	50,0	37,5	59,0	42,0	59,0	41,0	58,0	41,0		
70	68,5	71,0			50,0	37,5	59,0	42,0	61,0	41,0	61,0	41,0		
75	73,5	76,0			50,0	37,5	59,0	42,0	61,0	41,0	61,0	41,0		
80	78,5	81,0			50,0	37,5	59,0	47,0	61,0	46,0	61,0	46,0		
90	88,5	91,5					59,0	47,0		61,0		61,0		
100	98,5	101,5								61,0		61,0		
110	108,5	111,5								69,0*		68,0*		
120	118,5	121,5								69,0*		68,0*		
130	128,0	132,0										68,0*		
140	138,0	142,0										68,0*		
150	148,0	152,0										68,0*		
160	158,0	162,0										68,0*		

Intermediate lengths on Ls possible

Other thread lengths in the range $\geq 4 \times d1$ to max. standard length permitted.

* Design C with $lgT = \text{max. } 65,0 \text{ mm}$

	 SPAX [®] Pan head	Self-drilling screw with full and partial thread Material: cold rolled wire according to SPAX - Factory Standard Stainless steel screws
---	---	---

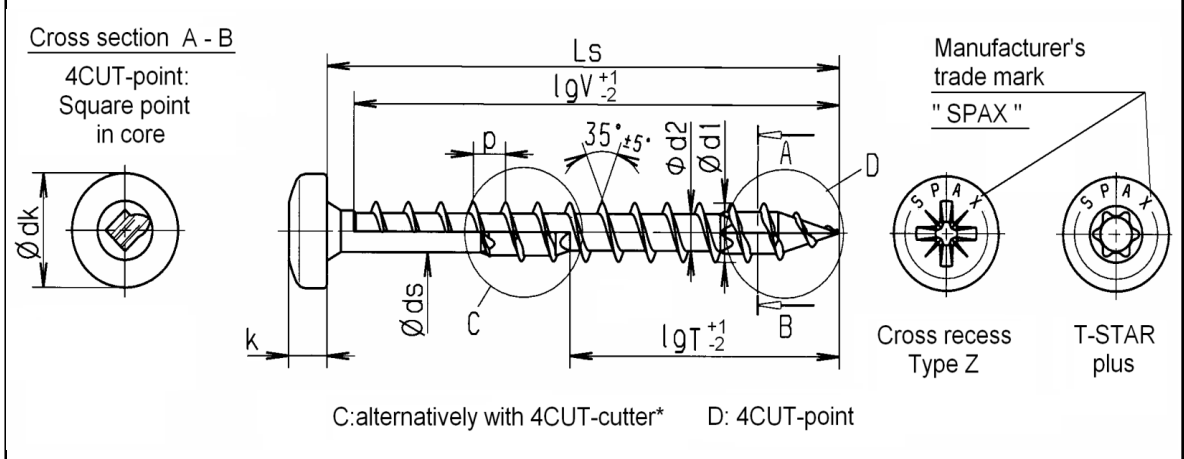

Nominal diameter			3,5	4,0	4,5	5,0	6,0
d1	thread size		3,5	4,0	4,5	5,1	6,1
	permissible tolerance		±0,20			±0,25	
dk	head diameter		7,0	8,0	9,0	9,9	11,9
	permissible tolerance		-0,40		-0,50		-0,60
d2	core diameter		2,5	2,8	3,2	3,5	4,0
	permissible tolerance		-0,30		-0,40		
ds	shank diameter		2,60	3,00	3,30	3,75	4,30
	permissible tolerance		±0,10				
k	head height max.		2,5	2,9	3,1	3,4	4,0
p	thread pitch		2,1	2,4	2,7	3,0	3,6
	permissible tolerance		±0,1 x p				
T-STAR plus size			T15	T20			T30
Cross recess size Z			2				3

Ls			Standard thread lengths (full thread = lgV / partial thread = lgT)													
Nom. dim.	min	max	lgV	lgT	lgV	lgT	lgV	lgT	lgV	lgT	lgV	lgT	lgV	lgT		
16	16,0	17,5	15,0													
20	18,5	20,5	18,0		18,0											
25	23,5	25,5	23,0	18,0	23,0			22,5		22,0						
30	28,5	30,5	27,0	18,0	27,5	18,0		27,5		27,0			27,0			
35	33,5	36,0	32,0	23,0	32,5	23,0		32,5	25,0	32,0	25,0	32,0				
40	38,5	41,0	37,0	23,0	37,5	23,0		37,0	25,0	37,0	27,0	37,0	24,0			
45	43,5	46,0	40,0	30,0	42,5	30,0		42,0	30,0	41,0	30,0	41,0	29,0			
50	48,5	51,0	40,0	32,0	47,5	32,5		47,0	32,5	46,0	32,0	46,0	32,0			
55	53,5	56,0		35,0	50,0	35,0		52,0	37,0	51,0	37,0	51,0	37,0			
60	58,5	61,0		35,0	50,0	35,0		57,0	37,0	56,0	37,0	56,0	37,0			
65	63,5	66,0		40,0	50,0	37,5		59,0	42,0	61,0	41,0	61,0	41,0			
70	68,5	71,0			50,0	37,5		59,0	42,0	61,0	41,0	61,0	41,0			
75	73,5	76,0			50,0	37,5		59,0	42,0	61,0	41,0	61,0	41,0			
80	78,5	81,0			50,0	37,5		59,0	47,0	61,0	46,0	61,0	46,0			
90	88,5	91,5						59,0	47,0		61,0		61,0			
100	98,5	101,5									61,0		61,0			
110	108,5	111,5									69,0*		68,0*			
120	118,5	121,5									69,0*		68,0*			
130	128,0	132,0											68,0*			
140	138,0	142,0											68,0*			
150	148,0	152,0											68,0*			
160	158,0	162,0											68,0*			

Intermediate lengths on Ls possible

Other thread lengths in the range ≥4xd1 to max. standard length permitted.



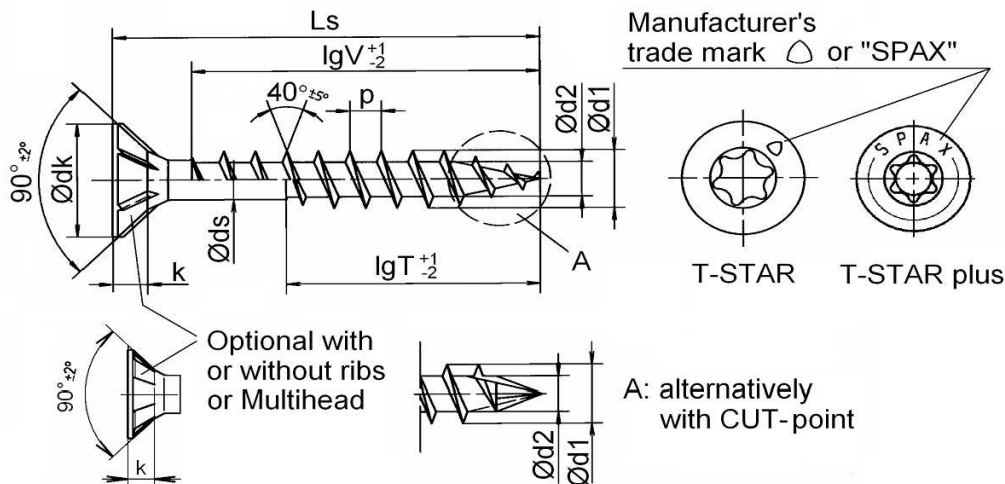

* Design C with lgT= max. 65,0 mm





	SPAX®-S Flat countersunk head	Self-drilling screw with full and partial thread Material: cold rolled wire according to SPAX - Factory standard Screws of high carbon steel

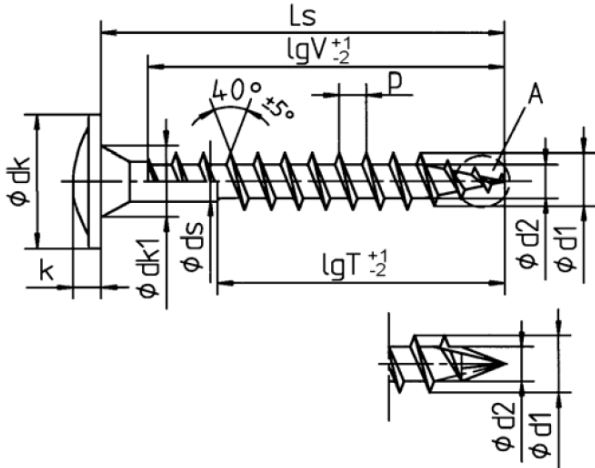

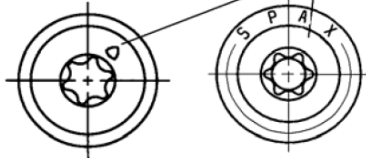
Nominal diameter		8,0	10,0	12,0						
d1	thread size	8,1	10,1	12,1						
	permissible tolerance		±0,40							
dk	head diameter	15,1	18,6	22,6						
	permissible tolerance		-0,60							
d2	core diameter	5,0	6,1	7,5						
	permissible tolerance		-0,30	-0,50						
ds	shank diameter	5,70	6,80	8,50						
	permissible tolerance		±0,25							
k	head height max.	4,4	5,4	6,6						
p	thread pitch	4,0	5,0	6,0						
	permissible tolerance		±0,1 x p							
T - STAR (plus) size		T40	T50	T50						
Ls		Standard thread lengths (full thread=lgV / partial thread = lgT)								
Nom.dim.	min	max	lgV	lgT	lgV	lgT	lgV	lgT		
40	38,5	41,5	32,0							
45	43,5	46,5	37,0							
50	48,5	51,5	42,0	32,0	40,0					
55	53,5	56,5	47,0	32,0	45,0					
60	58,5	61,5	52,0	37,0	50,0		50,0			
65	63,5	66,5	57,0	37,0	55,0	40,0	55,0			
70	68,5	71,5	61,0	42,0	60,0	40,0	60,0			
75	73,5	76,5	61,0	42,0	60,0	45,0	60,0			
80	78,5	81,5	70,0	47,0	70,0	50,0	70,0	50,0		
90	88,5	91,5	80,0	52,0	80,0	55,0	80,0	55,0		
100	98,5	101,5	80,0	57,0	80,0	60,0	80,0	60,0		
110	108,5	111,5	80,0	70,0	80,0	70,0		80,0		
120	118,5	121,5	80,0	70,0	80,0	70,0		80,0		
130	128,0	132,0	80,0	70,0	80,0	70,0		80,0		
140	138,0	142,0		80,0		80,0		80,0		
150	148,0	152,0		80,0		80,0		100,0		
160	158,0	162,0		80,0		80,0		100,0		
180	178,0	182,0		80,0		80,0		100,0		
200	198,0	202,0		80,0		80,0		100,0		
<i>to</i>										
600	597,0	602,0		80,0		80,0		100,0		

Intermediate lengths on Ls possible Other thread lengths in the range $\geq 4 \times d1$ to max. standard length permitted

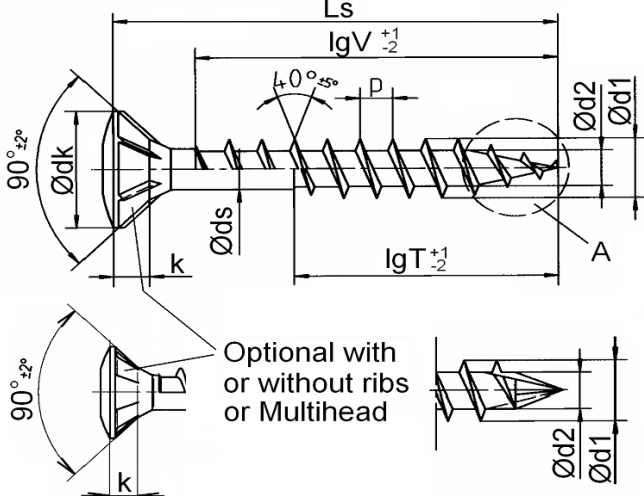
	 Washer head	Self-drilling screw with full and partial thread Material: cold rolled wire according to SPAX - Factory standard Screws of high carbon steel							
			Manufacturer's trade mark  or "SPAX"  T - STAR T-STAR plus A: alternatively with CUT-point						
Nominal diameter		8,0		10,0	12,0				
d1	thread size	8.1		10.1	12.1				
	permissible tolerance	±0,40							
dk	head diameter	18,0	20,0	22,0	25,0	31,0			
	permissible tolerance	±1,0							
dk1	countersink diameter	9,0		12,0	14,0				
	permissible tolerance	+0,30							
d2	core diameter	5,0		6,1	7,5				
	permissible tolerance	-0,30			-0,5				
ds	shank diameter	5,70		6,80	8,50				
	permissible tolerance	±0,25							
k	head height max.	4,0		4,7	5,6				
p	thread pitch	4,0		5,0	6,0				
	permissible tolerance	±0,1 x p							
T - STAR (plus) size		T40			T50				
Ls		Standard thread lengths (full thread=lgV / partial thread = lgT)							
Nom. dim.	min	max	lgV	lgT	lgV	lgT	lgV	lgT	
40	38,5	41,5	37,0						
45	43,5	46,5	42,0						
50	48,5	51,5	46,0	32,0					
55	53,5	56,5	51,0	32,0	50,0		50,0		
60	58,5	61,5	56,0	37,0	55,0		55,0		
65	63,5	66,5	61,0	37,0	60,0	40,0	60,0		
70	68,5	71,5	61,0	42,0	60,0	40,0	60,0		
75	73,5	76,5	70,0	42,0	70,0	45,0	70,0		
80	78,5	81,5	70,0	47,0	70,0	50,0	70,0	50,0	
90	88,5	91,5	80,0	52,0	80,0	55,0	80,0	55,0	
100	98,5	101,5	80,0	57,0	80,0	60,0	80,0	60,0	
110	108,5	111,5	80,0	70,0	80,0	70,0		80,0	
120	118,5	121,5	80,0	70,0	80,0	70,0		80,0	
130	128,0	132,0	80,0	70,0	80,0	70,0		80,0	
140	138,0	142,0		80,0		80,0		80,0	
150	148,0	152,0		80,0		80,0		100,0	
160	158,0	162,0		80,0		80,0		100,0	
180	178,0	182,0		80,0		80,0		100,0	
200	198,0	202,0		80,0		80,0		100,0	
to									
600	597,0	602,0		80,0		80,0		100,0	
Intermediate lengths on Ls possible					Other thread lengths in the range ≥4xd1 to max. standard length permitted				
Annex A28									

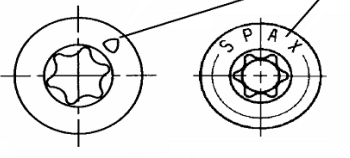
	 SPAX[®]-S Raised countersunk head	Self-drilling screw with full and partial thread Material: cold rolled wire according to SPAX - Factory standard Screws of high carbon steel																
			Manufacturer's trade mark  or "SPAX"  T-STAR T-STAR plus A: alternatively with CUT-point															
Nominal diameter		8,0	10,0	12,0														
d1	thread size	8,1	10,1	12,1														
	permissible tolerance	±0,40																
dk	head diameter	15,1	18,6	22,6														
	permissible tolerance	-0,60																
d2	core diameter	5,0	6,1	7,5														
	permissible tolerance	-0,30																
ds	shank diameter	5,70	6,80	8,50														
	permissible tolerance	±0,25																
k	head height max.	4,4	5,4	6,6														
p	thread pitch	4,0	5,0	6,0														
	permissible tolerance	±0,1 x p																
T - STAR (plus) size		T40	T50	T50														
Ls		Standard thread lengths (full thread=lgV / partial thread = lgT)																
Nom.dim.	min	max	lgV	lgT	lgV	lgT	lgV	lgT	lgV	lgT								
40	38,5	41,5	32,0															
45	43,5	46,5	37,0															
50	48,5	51,5	42,0	32,0	40,0													
55	53,5	56,5	47,0	32,0	45,0													
60	58,5	61,5	52,0	37,0	50,0			50,0										
65	63,5	66,5	57,0	37,0	55,0	40,0	55,0											
70	68,5	71,5	61,0	42,0	60,0	40,0	60,0											
75	73,5	76,5	61,0	42,0	60,0	45,0	60,0											
80	78,5	81,5	70,0	47,0	70,0	50,0	70,0	50,0										
90	88,5	91,5	80,0	52,0	80,0	55,0	80,0	55,0										
100	98,5	101,5	80,0	57,0	80,0	60,0	80,0	60,0										
110	108,5	111,5	80,0	70,0	80,0	70,0		80,0										
120	118,5	121,5	80,0	70,0	80,0	70,0		80,0										
130	128,0	132,0	80,0	70,0	80,0	70,0		80,0										
140	138,0	142,0		80,0		80,0		80,0										
150	148,0	152,0		80,0		80,0		100,0										
160	158,0	162,0		80,0		80,0		100,0										
180	178,0	182,0		80,0		80,0		100,0										
200	198,0	202,0		80,0		80,0		100,0										
to																		
600	597,0	602,0		80,0		80,0		100,0										
Intermediate lengths on Ls possible					Other thread lengths in the range ≥4xd1 to max. standard length permitted													
Annex A29																		

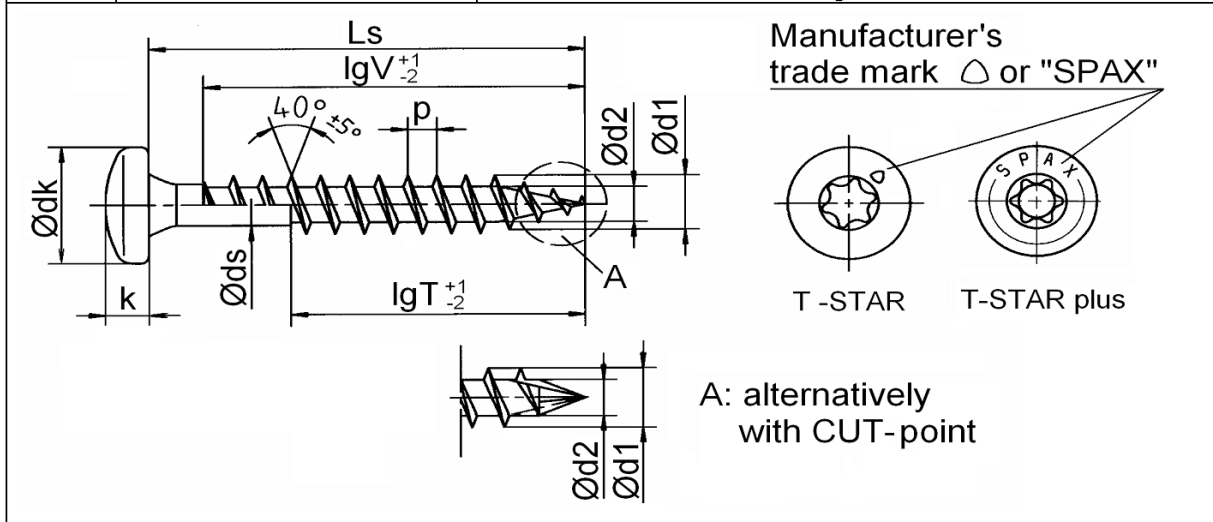

	SPAX®-S Pan head	Self-drilling screw with full and partial thread Material: cold rolled wire according to SPAX - Factory standard Screws of high carbon steel



Nominal diameter		8,0	10,0	12,0			
d1	thread size	8,1	10,1	12,1			
	permissible tolerance		$\pm 0,40$				
dk	head diameter	15,5	19,0	23,0			
	permissible tolerance		-0,60				
d2	core diameter	5,0	6,1	7,5			
	permissible tolerance		-0,30	-0,50			
ds	shank diameter	5,70	6,80	8,50			
	permissible tolerance		$\pm 0,25$				
k	head height max.	5,7	7,1	8,5			
R	raised radius	16,0	20,0	24,0			
p	thread pitch	4,0	5,0	6,0			
	permissible tolerance		$\pm 0,1 \times p$				
T - STAR (plus) size		T40	T50	T50			

Ls			Standard thread lengths (full thread=lgV / partial thread = lgT)									
Nom. dim.	min	max	lgV	lgT	lgV	lgT	lgV	lgT				
40	38,0	41,5	37,0									
45	43,0	46,5	42,0									
50	48,5	51,5	46,0	32,0								
55	53,5	56,5	51,0	32,0	50,0			50,0				
60	58,5	61,5	56,0	37,0	55,0			55,0				
65	63,5	66,5	61,0	37,0	60,0	40,0		60,0				
70	68,5	71,5	61,0	42,0	60,0	40,0		60,0				
75	73,5	76,5	70,0	42,0	70,0	45,0		70,0				
80	78,5	81,5	70,0	47,0	70,0	50,0		70,0	50,0			
90	88,5	91,5	80,0	52,0	80,0	55,0		80,0	55,0			
100	98,5	101,5	80,0	57,0	80,0	60,0		80,0	60,0			
110	108,5	111,5	80,0	70,0	80,0	70,0			80,0			
120	118,5	121,5	80,0	70,0	80,0	70,0			80,0			
130	128,0	132,0	80,0	70,0	80,0	70,0			80,0			
140	138,0	142,0		80,0		80,0			80,0			
150	148,0	152,0		80,0		80,0			100,0			
160	158,0	162,0		80,0		80,0			100,0			
180	178,0	182,0		80,0		80,0			100,0			
200	198,0	202,0		80,0		80,0			100,0			
to												
600	597,0	602,0		80,0		80,0			100,0			

Intermediate lengths on Ls possible Other thread lengths in the range $\geq 4 \times d1$ to max. standard length permitted

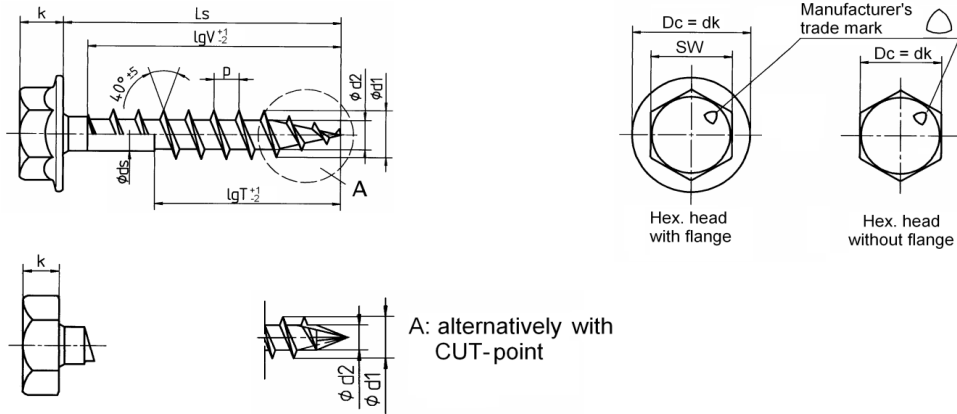

		Self-drilling screw with full and partial thread
	Hex. head with/without flange	Material: cold rolled wire according to SPAX - Factory standard Screws of high carbon steel



			with flange				without flange							
Nominal diameter			8,0	10,0	12,0	8,0	10,0	12,0	8,0	10,0	12,0			
d1	thread size		8,1	10,1	12,1	8,1	10,1	12,1	8,1	10,1	12,1			
	permissible tolerance		±0,40				±0,40							
SW	width across flat		10	13	16	10	13	16						
Dc	flange diameter		17,0	20,8	24,7									
	permissible tolerance		-1,00											
d2	core diameter		5,0	6,1	7,5	5,0	6,1	7,5						
	permissible tolerance		-0,30		-0,50		-0,30		-0,50					
ds	shank diameter		5,70	6,80	8,50	5,70	6,80	8,50						
	permissible tolerance		±0,25				±0,25							
k	head height max.		8,5	9,7	12,1	6,0	7,0	8,0						
p	thread pitch		4,0	5,0	6,0	4,0	5,0	6,0						
	permissible tolerance		±0,1 x p				±0,1 x p							
Ls			Standard thread lengths (full thread=lgV / partial thread = lgT)											
Nom.dim.	min	max	lgV	lgT	lgV	lgT	lgV	lgT	lgV	lgT	lgV	lgT	lgV	lgT
40	38,5	41,5	37,0						37,0					
45	43,5	46,5	42,0						42,0					
50	48,5	51,5	46,0	32,0	45,0				46,0	32,0	45,0			
55	53,5	56,5	51,0	32,0	50,0		50,0		51,0	32,0	50,0		50,0	
60	58,5	61,5	56,0	37,0	55,0		55,0		56,0	37,0	55,0		55,0	
65	63,5	66,5	61,0	37,0	60,0	40,0	60,0		61,0	37,0	60,0	40,0	60,0	
70	68,5	71,5	61,0	42,0	60,0	40,0	60,0		61,0	42,0	60,0	40,0	60,0	
75	73,5	76,5	70,0	42,0	70,0	45,0	70,0		70,0	42,0	70,0	45,0	70,0	
80	78,5	81,5	70,0	47,0	70,0	50,0	70,0	50,0	70,0	47,0	70,0	50,0	70,0	50,0
90	88,5	91,5	80,0	52,0	80,0	55,0	80,0	55,0	80,0	52,0	80,0	55,0	80,0	55,0
100	98,5	101,5	80,0	57,0	80,0	60,0	80,0	60,0	80,0	57,0	80,0	60,0	80,0	60,0
110	108,5	111,5	80,0	70,0	80,0	70,0		80,0	80,0	70,0	80,0	70,0		80,0
120	118,5	121,5	80,0	70,0	80,0	70,0		80,0	80,0	70,0	80,0	70,0		80,0
130	128,0	132,0	80,0	70,0	80,0	70,0		80,0	80,0	70,0	80,0	70,0		80,0
140	138,0	142,0		80,0		80,0		80,0		80,0		80,0		80,0
150	148,0	152,0		80,0		80,0		100,0		80,0		80,0		100,0
160	158,0	162,0		80,0		80,0		100,0		80,0		80,0		100,0
180	178,0	182,0		80,0		80,0		100,0		80,0		80,0		100,0
200	198,0	202,0		80,0		80,0		100,0		80,0		80,0		100,0
to														
600	597,0	602,0		80,0		80,0		100,0		80,0		80,0		100,0

Intermediate lengths on Ls possible

Other thread lengths in the range ≥4xd1 to max. standard length permitted

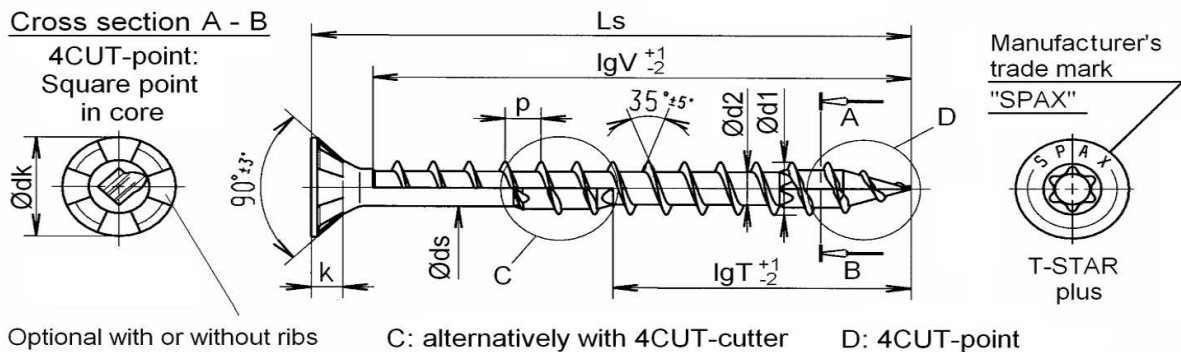

	 SPAX [®] Flat countersunk head	Self-drilling screw with full and partial thread Material: cold rolled wire according to SPAX - Factory standard Screws of high carbon steel



Nominal diameter		8,0	10,0					
d1	thread size	8,1	10,1					
	permissible tolerance	±0,40	±0,40					
dk	head diameter	15,1	18,6					
	permissible tolerance	-0,60	-0,60					
d2	core diameter	5,0	6,1					
	permissible tolerance	±0,20	±0,20					
ds	shank diameter	5,70	6,80					
	permissible tolerance	±0,25	±0,25					
k	head height max.	4,4	5,4					
p	thread pitch	4,8	6,0					
	permissible	±0,1 x p	±0,1 x p					
T-STAR plus size		T40	T50					

Ls			Standard thread lengths (full thread=lgV / partial thread = lgT)					
Nom. dim.	min	max	lgV	lgT				
40	38,5	41,5	32,0					
45	43,5	46,5	37,0					
50	48,5	51,5	42,0	32,0	40,0			
55	53,5	56,5	47,0	32,0	45,0			
60	58,5	61,5	52,0	37,0	50,0			
65	63,5	66,5	57,0	37,0	55,0			
70	68,5	71,5	61,0	42,0	60,0			
75	73,5	76,5	61,0	42,0	60,0			
80	78,5	81,5	70,0	47,0	70,0	50,0		
90	88,5	91,5	80,0	52,0	80,0	55,0		
100	98,5	101,5	80,0	57,0	80,0	60,0		
110	108,5	111,5	80,0	70,0	80,0	80,0		
120	118,5	121,5	80,0	70,0	80,0	80,0		
130	128,0	132,0	80,0	70,0	80,0	80,0		
140	138,0	142,0		80,0		80,0		
150	148,0	152,0		80,0		80,0		
160	158,0	162,0		80,0		80,0		
180	178,0	182,0		80,0		80,0		
200	198,0	202,0		80,0		80,0		
<i>to</i>								
600	597,0	602,0		80,0		80,0		

Intermediate lengths on Ls possible Other thread lengths in the range ≥4xd1 to max. standard length permitted

	 Washer head	Self-drilling screw with full and partial thread Material: cold rolled wire according to SPAX - Factory standard Screws of high carbon steel

Cross section A - B

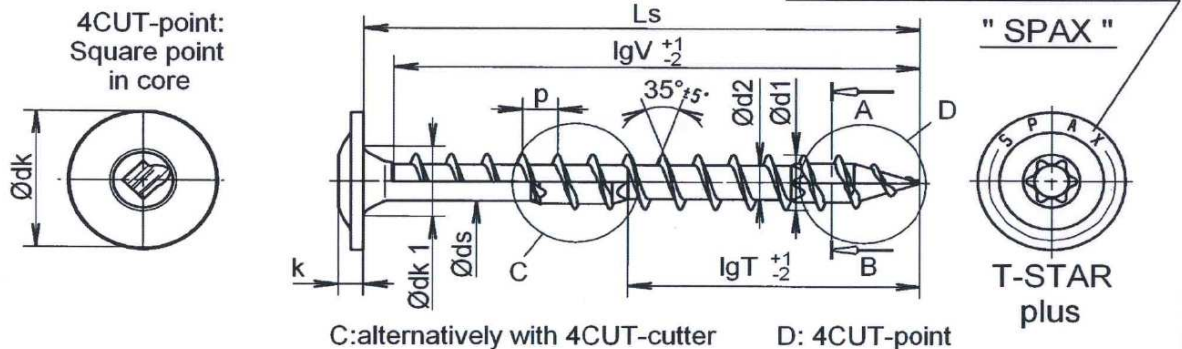



Nominal diameter	8,0				10,0				
d1	thread size		8,1		thread size		10,0		
	permissible tolerance		±0,40		permissible tolerance		±0,40		
dk	head diameter	18,0	20,0	22,0	24,0	head diameter	24,0	25,0	26,0
	permissible tolerance	±1,0				permissible tolerance	±1,0		
dk1	countersink diameter		9,00		countersink diameter		12,00		
	permissible tolerance		+0,50		permissible tolerance		+0,5		
d2	core diameter		5,0		core diameter		6,1		
	permissible tolerance		±0,20		permissible tolerance		±0,20		
ds	shank diameter		5,70		shank diameter		6,80		
	permissible tolerance		±0,25		permissible tolerance		±0,25		
k	head height max.		4,3		head height max.		4,7		
p	thread pitch		4,8		thread pitch		6,0		
	permissible tolerance		±0,1 x p		permissible tolerance		±0,1 x p		
T-STAR plus size			T40				T50		

Ls			Standard thread lengths (full thread=lgV / partial thread = lgT)			
Nom.dim.	min	max	lgV	lgT	lgV	lgT
40	38,5	41,5	37,0			
45	43,5	46,5	42,0			
50	48,5	51,5	46,0	32,0	40,0	
55	53,5	56,5	51,0	32,0	45,0	
60	58,5	61,5	56,0	37,0	50,0	
65	63,5	66,5	61,0	37,0	55,0	
70	68,5	71,5	61,0	42,0	60,0	
75	73,5	76,5	70,0	42,0	70,0	50,0
80	78,5	81,5	70,0	47,0	80,0	55,0
90	88,5	91,5	80,0	52,0	80,0	60,0
100	98,5	101,5	80,0	57,0	80,0	80,0
110	108,5	111,5	80,0	70,0	80,0	80,0
120	118,5	121,5	80,0	70,0	80,0	80,0
130	128,0	132,0	80,0	70,0	80,0	80,0
140	138,0	142,0		80,0		80,0
150	148,0	152,0		80,0		80,0
160	158,0	162,0		80,0		80,0
180	178,0	182,0		80,0		80,0
200	198,0	202,0		80,0		80,0
to						
600	597,0	602,0		80,0		80,0

Intermediate lengths on Ls possible
 = Preferred size

Other thread lengths in the range ≥4xd1 to max. standard length permitted

		Self-drilling screw with full and partial thread
	Raised countersunk head	Material: cold rolled wire according to SPAX - Factory standard Screws of high carbon steel

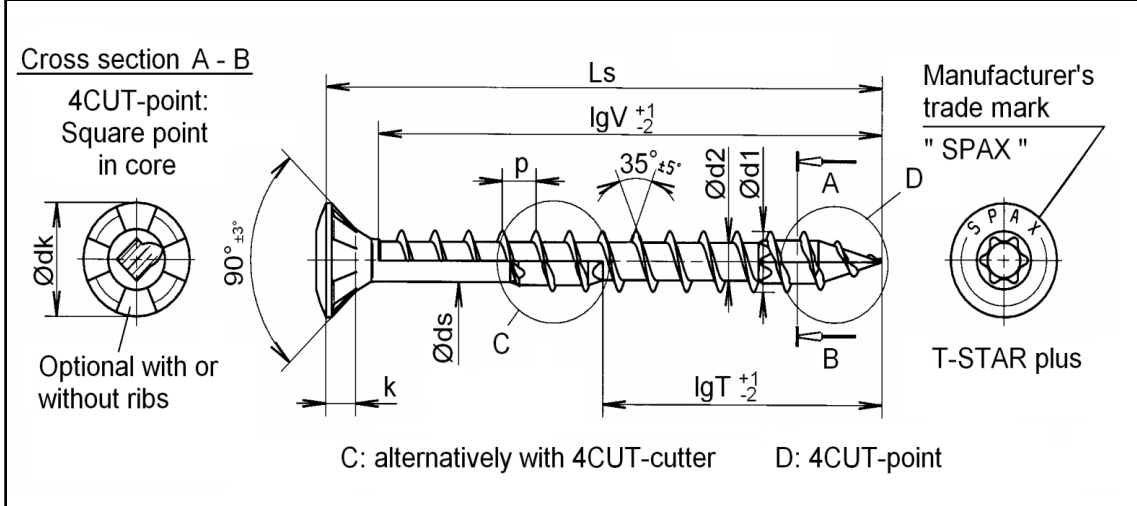



Nominal diameter	8,0	10,0							
d1	thread size	8,1	10,0						
	permissible tolerance	±0,40	±0,40						
dk	head diameter	15,1	18,6						
	permissible tolerance	-0,60	-0,60						
d2	core diameter	5,0	6,1						
	permissible tolerance	±0,20	±0,20						
ds	shank diameter	5,70	6,80						
	permissible tolerance	±0,25	±0,25						
k	head height max.	4,4	5,4						
p	thread pitch	4,8	6,0						
	permissible tolerance	±0,1 x p	±0,1 x p						
T-STAR plus size		T40	T50						

Ls			Standard thread lengths (full thread=lgV / partial thread = lgT)							
Nom.dim.	min	max	lgV	lgT						
40	38,5	41,5	32,0							
45	43,5	46,5	37,0							
50	48,5	51,5	42,0	32,0	40,0					
55	53,5	56,5	47,0	32,0	45,0					
60	58,5	61,5	52,0	37,0	50,0					
65	63,5	66,5	57,0	37,0	55,0					
70	68,5	71,5	61,0	42,0	60,0					
75	73,5	76,5	61,0	42,0	60,0					
80	78,5	81,5	70,0	47,0	70,0	50,0				
90	88,5	91,5	80,0	52,0	80,0	55,0				
100	98,5	101,5	80,0	57,0	80,0	60,0				
110	108,5	111,5	80,0	70,0	80,0	80,0				
120	118,5	121,5	80,0	70,0	80,0	80,0				
130	128,0	132,0	80,0	70,0	80,0	80,0				
140	138,0	142,0		80,0		80,0				
150	148,0	152,0		80,0		80,0				
160	158,0	162,0		80,0		80,0				
180	178,0	182,0		80,0		80,0				
200	198,0	202,0		80,0		80,0				
<i>to</i>										
600	597,0	602,0		80,0		80,0				

Intermediate lengths on Ls possible

Other thread lengths in the range ≥4xd1 to max. standard length permitted

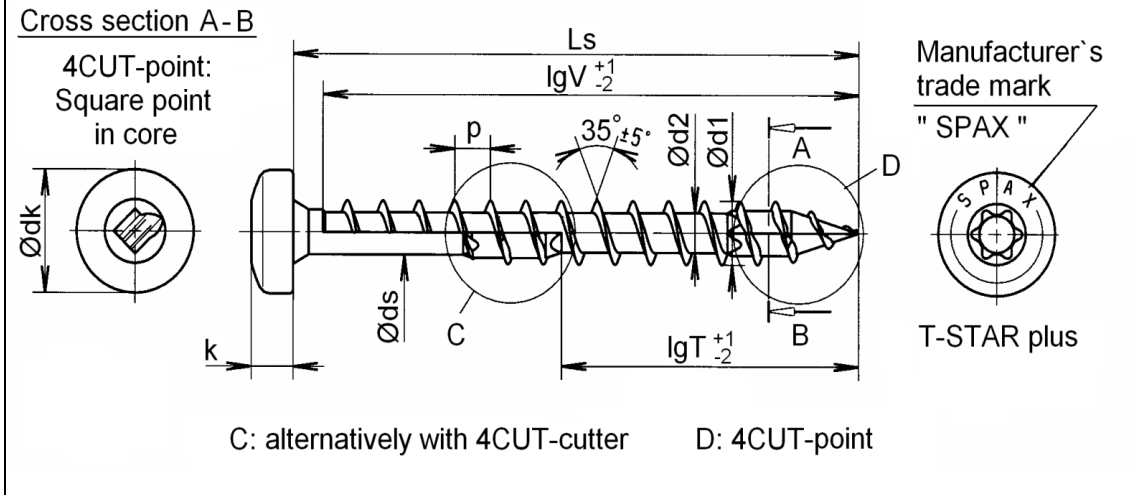

	 Pan head	Self-drilling screw with full and partial thread Material: cold rolled wire according to SPAX - Factory standard Screws of high carbon steel
---	---	--



Nominal diameter		8,0	10,0				
d1	thread size	8,1	10,0				
	permissible tolerance	±0,40	±0,40				
dk	head diameter	15,5	19,0				
	permissible tolerance	-0,60	-0,60				
d2	core diameter	5,0	6,1				
	permissible tolerance	±0,20	±0,20				
ds	shank diameter	5,70	6,80				
	permissible tolerance	±0,25	±0,25				
k	head height max.	6,0	7,1				
p	thread pitch	4,8	6,0				
	permissible tolerance	±0,1 x p	±0,1 x p				
T-STAR plus size		T40	T50				

Ls			Standard thread lengths (full thread=lgV / partial thread = lgT)				
Nom.dim.	min	max	lgV	lgT			
40,0	38,5	41,5	37,0				
45,0	43,5	56,5	42,0				
50	48,5	51,5	46,0	32,0	40,0		
55	53,5	56,5	51,0	32,0	45,0		
60	58,5	61,5	56,0	37,0	50,0		
65	63,5	66,5	61,0	37,0	55,0		
70	68,5	71,5	61,0	42,0	60,0		
75	73,5	76,5	70,0	42,0	60,0		
80	78,5	81,5	70,0	47,0	70,0	50,0	
90	88,5	91,5	80,0	52,0	80,0	55,0	
100	98,5	101,5	80,0	57,0	80,0	60,0	
110	108,5	111,5	80,0	70,0	80,0	80,0	
120	118,5	121,5	80,0	70,0	80,0	80,0	
130	128,0	132,0	80,0	70,0	80,0	80,0	
140	138,0	142,0		80,0		80,0	
150	148,0	152,0		80,0		80,0	
160	158,0	162,0		80,0		80,0	
180	178,0	182,0		80,0		80,0	
200	198,0	202,0		80,0		80,0	
to							
600	597,0	602,0		80,0		80,0	

Intermediate lengths on Ls possible Other thread lengths in the range ≥4xd1 to max. standard length permitted

		Self-drilling screw with full and partial thread
	Hex. Head with/without flange	Material: cold rolled wire according to SPAX - Factory standard Screws of high carbon steel

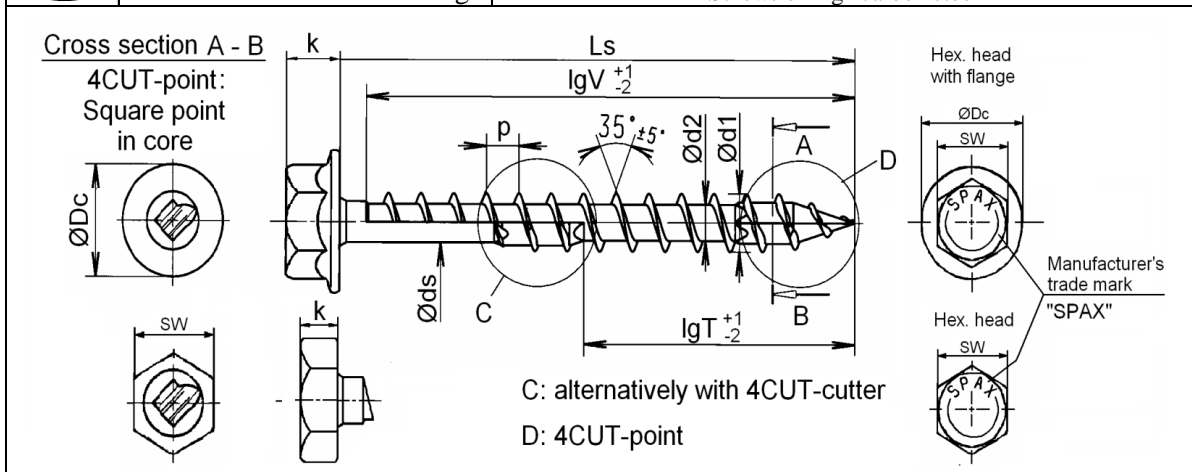

	with flange		without flange	with flange	without flange
Nominal diameter	8,0		8,0	10,0	10,0
d1 thread size	8,1		8,1	10,0	10,0
permissible tolerance	±0,40		±0,40	±0,40	±0,40
SW wrench size	10		10	13	13
Dc flange diameter	17,0		-	20,8	-
permissible tolerance	-1,00		-	-1,00	-
d2 core diameter	5,0		5,0	6,1	6,1
permissible tolerance	±0,20		±0,20	±0,20	±0,20
ds shank diameter	5,70		5,70	6,80	6,80
permissible tolerance	±0,25		±0,25	±0,25	±0,25
k head height max.	4,4		4,4	9,7	7,0
p thread pitch	4,8		4,8	6,0	6,0
permissible tolerance	±0,1 x p		±0,1 x p	±0,1 x p	±0,1 x p

Ls		Standard thread lengths (full thread=lgV / partial thread = lgT)										
Nom.dim.	min	max	lgV	lgT								
40	38,5	41,5	32,0									
45	43,5	46,5	37,0									
50	48,5	51,5	42,0	32,0					40,0		40,0	
55	53,5	56,5	47,0	32,0					45,0		45,0	
60	58,5	61,5	52,0	37,0					50,0		50,0	
65	63,5	66,5	57,0	37,0					55,0		55,0	
70	68,5	71,5	61,0	42,0					60,0		60,0	
75	73,5	76,5	61,0	42,0					60,0		60,0	
80	78,5	81,5	70,0	47,0					70,0	50,0	70,0	50,0
90	88,5	91,5	80,0	52,0					80,0	55,0	80,0	55,0
100	98,5	101,5	80,0	57,0					80,0	60,0	80,0	60,0
110	108,5	111,5	80,0	70,0					80,0	80,0	80,0	80,0
120	118,5	121,5	80,0	70,0					80,0	80,0	80,0	80,0
130	128,0	132,0	80,0	70,0					80,0	80,0	80,0	80,0
140	138,0	142,0		80,0					80,0		80,0	
150	148,0	152,0		80,0					80,0		80,0	
160	158,0	162,0		80,0					80,0		80,0	
180	178,0	182,0		80,0					80,0		80,0	
200	198,0	202,0		80,0					80,0		80,0	
<i>to</i>												
600	597,0	602,0		80,0					80,0		80,0	

Intermediate lengths on Ls possible

Other thread lengths in the range ≥4xd1 to max. standard length permitted

	SPAX® Flat countersunk head	Self-drilling screw with full and partial thread Material: cold rolled wire according to SPAX - Factory standard Stainless steel screws

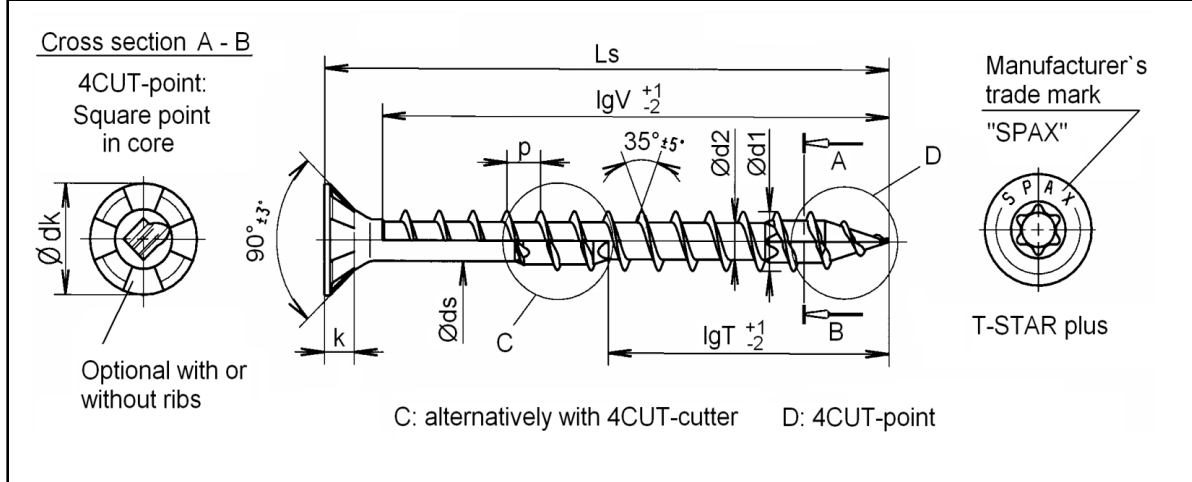



Nominal diameter	8,0								
d1	thread size	8,1							
	permissible tolerance	±0,40							
dk	head diameter	15,1							
	permissible tolerance	-1,0							
d2	core diameter	5,3							
	permissible tolerance	±0,20							
ds	shank diameter	5,70							
	permissible tolerance	±0,25							
k	head height max.	4,4							
p	thread pitch	4,8							
	permissible tolerance	±0,1 x p							
T-STAR plus size		T40							

Ls		Standard thread lengths (full thread=lgV / partial thread = lgT)							
Nom.dim.	min	max	lgV	lgT					
40	38,5	41,5	32,0						
45	43,5	46,5	37,0						
50	48,5	51,5	42,0	32,0					
55	53,5	56,5	47,0	32,0					
60	58,5	61,5	52,0	37,0					
65	63,5	66,5	57,0	37,0					
70	68,5	71,5	61,0	42,0					
75	73,5	76,5	61,0	42,0					
80	78,5	81,5	70,0	47,0					
90	88,5	91,5	80,0	52,0					
100	98,5	101,5	80,0	57,0					
110	108,5	111,5	80,0	70,0					
120	118,5	121,5	80,0	70,0					
130	128,0	132,0	80,0	70,0					
140	138,0	142,0		80,0					
150	148,0	152,0		80,0					
160	158,0	162,0		80,0					
180	178,0	182,0		80,0					
200	197,0	202,0		80,0					
to									
600	597,0	602,0		80,0					

Intermediate lengths on Ls possible

Other thread lengths in the range $\geq 4 \times d1$ to max. standard length permitted

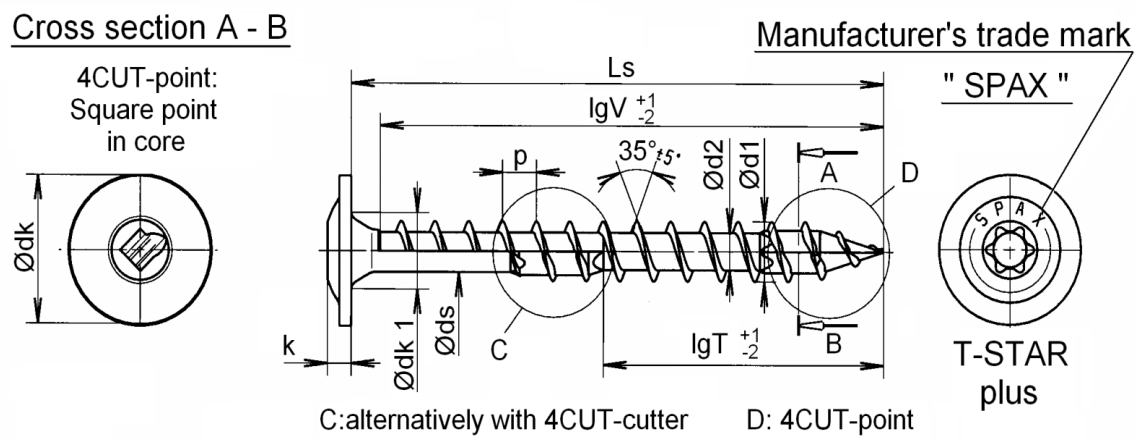

	 Washer head	Self-drilling screw with full and partial thread
		Material: cold rolled wire according to SPAX - Factory standard Stainless steel screws



Nominal diameter	8,0							
d1	thread size	8,1						
	permissible tolerance	±0,40						
dk	head diameter	18,0	20,0	22,0	24,0			
	permissible tolerance	±1,0						
dk1	countersink diameter	9,00						
	permissible tolerance	+0,50						
d2	core diameter	5,3						
	permissible tolerance	±0,20						
ds	shank diameter	5,70						
	permissible tolerance	±0,25						
k	head height max.	4,3						
p	thread pitch	4,8						
	permissible tolerance	±0,1 x p						
T-STAR plus size		T40						
Ls		Standard thread lengths (full thread=lgV / partial thread = lgT)						
Nom.dim.	min	max	lgV	lgT				
40	37,5	41,5	37,0					
45	43,5	46,5	42,0					
50	48,5	51,5	46,0	32,0				
55	53,5	56,5	51,0	32,0				
60	58,5	61,5	56,0	37,0				
65	63,5	66,5	61,0	37,0				
70	68,5	71,5	61,0	42,0				
75	73,5	76,5	70,0	42,0				
80	78,5	81,5	70,0	47,0				
90	88,5	91,5	80,0	52,0				
100	98,5	101,5	80,0	57,0				
110	108,5	111,5	80,0	70,0				
120	118,5	121,5	80,0	70,0				
130	128,0	132,0	80,0	70,0				
140	138,0	142,0		80,0				
150	148,0	152,0		80,0				
160	158,0	162,0		80,0				
180	178,0	182,0		80,0				
200	197,0	202,0		80,0				
to								
600	597,0	602,0		80,0				

Intermediate lengths on Ls possible
 = Preferred size

Other thread lengths in the range ≥4xd1 to max. standard length permitted

	 SPAX [®] Raised countersunk head	Self-drilling screw with full and partial thread
		Material: cold rolled wire according to SPAX - Factory standard Stainless steel screws

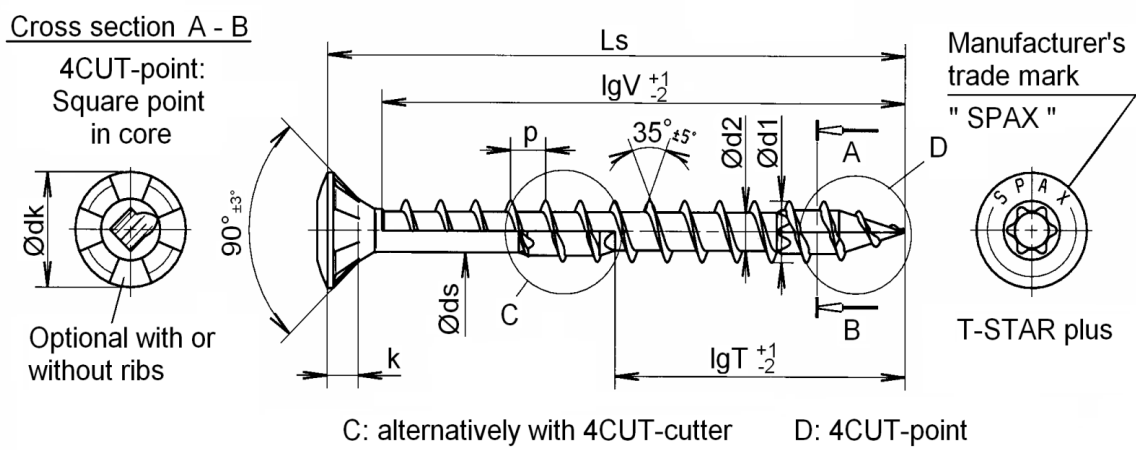





Nominal diameter	8,0									
d1	thread size	8,1								
	permissible tolerance	±0,40								
dk	head diameter	15,1								
	permissible tolerance	-1,0								
d2	core diameter	5,3								
	permissible tolerance	±0,20								
ds	shank diameter	5,70								
	permissible tolerance	±0,25								
k	head height max.	4,4								
p	thread pitch	4,8								
	permissible tolerance	±0,1 x p								
T-STAR plus size		T40								

Ls			Standard thread lengths (full thread=lgV / partial thread = lgT)							
Nom.dim.	min	max	lgV	lgT						
40	38,5	41,5	32,0							
45	43,5	46,5	37,0							
50	48,5	51,5	42,0	32,0						
55	53,5	56,5	47,0	32,0						
60	58,5	61,5	52,0	37,0						
65	63,5	66,5	57,0	37,0						
70	68,5	71,5	61,0	42,0						
75	73,5	76,5	61,0	42,0						
80	78,5	81,5	70,0	47,0						
90	88,5	91,5	80,0	52,0						
100	98,5	101,5	80,0	57,0						
110	108,5	111,5	80,0	70,0						
120	118,5	121,5	80,0	70,0						
130	128,0	132,0	80,0	70,0						
140	138,0	142,0		80,0						
150	148,0	152,0		80,0						
160	158,0	162,0		80,0						
180	178,0	182,0		80,0						
200	198,0	202,0		80,0						
<i>to</i>										
600	597,0	602,0		80,0						

Intermediate lengths on Ls possible

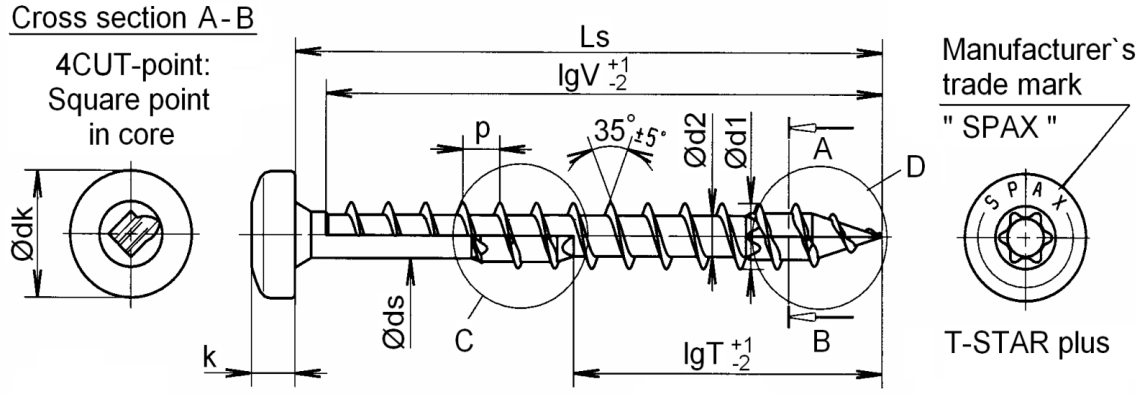
Other thread lengths in the range ≥4xd1 to max. standard length permitted



			Self-drilling screw with full and partial thread								
	Pan head		Material: cold rolled wire according to SPAX - Factory standard Stainless steel screws								
<p>Cross section A-B</p>  <p>4CUT-point: Square point in core</p> <p>Manufacturer's trade mark " SPAX "</p> <p>T-STAR plus</p> <p>C: alternatively with 4CUT-cutter D: 4CUT-point</p>											
Nominal diameter			8,0								
d1	thread size		8,1								
	permissible tolerance		±0,40								
dk	head diameter		15,5								
	permissible tolerance		-1,0								
d2	core diameter		5,3								
	permissible tolerance		±0,20								
ds	shank diameter		5,70								
	permissible tolerance		±0,25								
k	head height max.		6,0								
p	thread pitch		4,8								
	permissible tolerance		±0,1 x p								
T-STAR plus size			T40								
Ls			Standard thread lengths (full thread=lgV / partial thread = lgT)								
Nom.dim.	min	max	lgV	lgT							
40	38,5	41,5	37,0								
45	43,5	46,5	42,0								
50	48,5	51,5	46,0	32,0							
55	53,5	56,5	51,0	32,0							
60	58,5	61,5	56,0	37,0							
65	63,5	66,5	61,0	37,0							
70	68,5	71,5	61,0	42,0							
75	73,5	76,5	70,0	42,0							
80	78,5	81,5	70,0	47,0							
90	88,5	91,5	80,0	52,0							
100	98,5	101,5	80,0	57,0							
110	108,5	111,5	80,0	70,0							
120	118,5	121,5	80,0	70,0							
130	128,0	132,0	80,0	70,0							
140	138,0	142,0		80,0							
150	148,0	152,0		80,0							
160	158,0	162,0		80,0							
180	178,0	182,0		80,0							
200	198,0	202,0		80,0							
<i>to</i>											
600	597,0	202,0		80,0							
Intermediate lengths on Ls possible					Other thread lengths in the range $\geq 4d1$ to max. standard length permitted						
Annex A40											

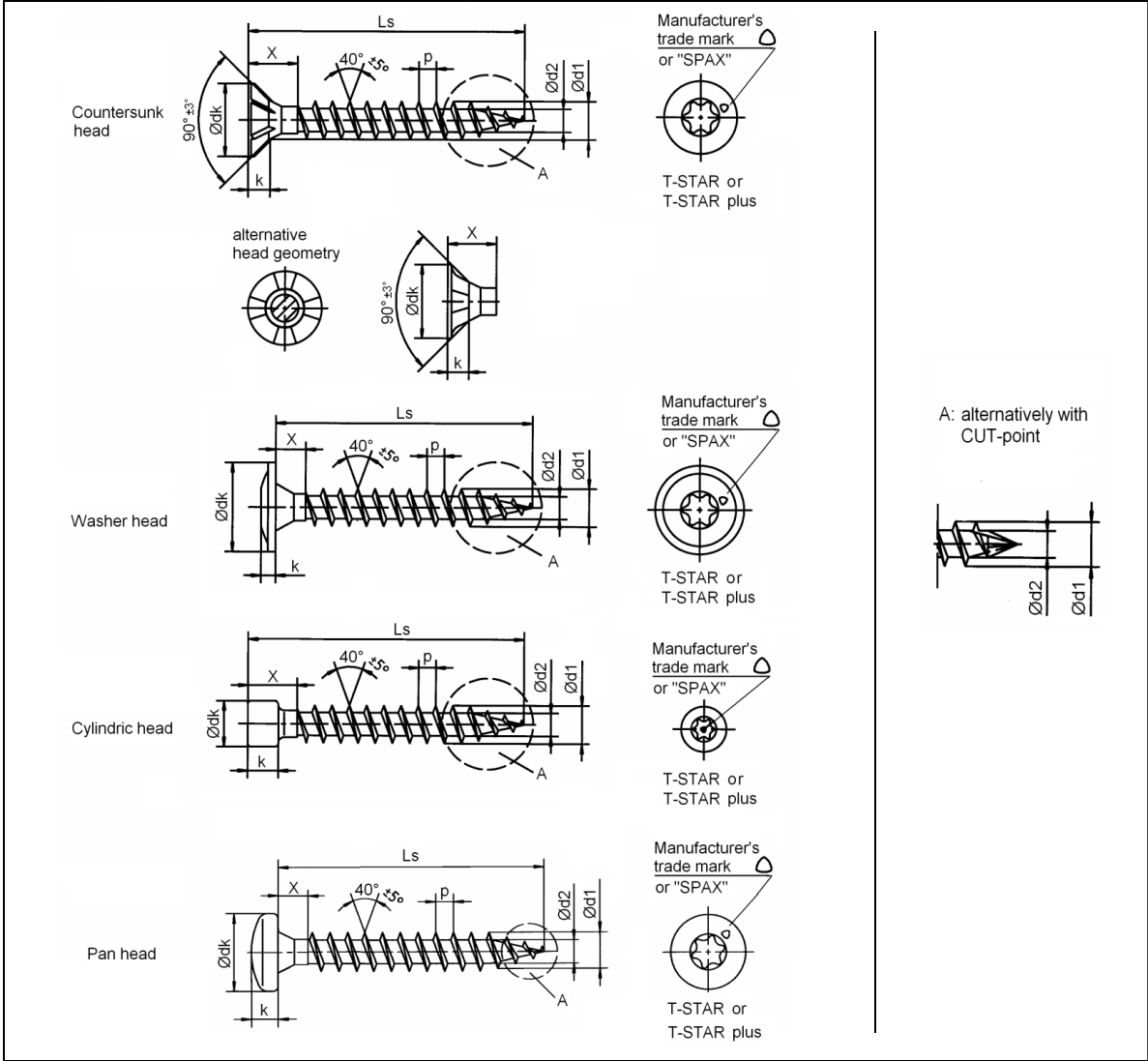







		Full- thread, self-drilling screw Material: Cold rolled wire according to SPAX - Factory Standard Screws of high-carbon steel
---	---	--

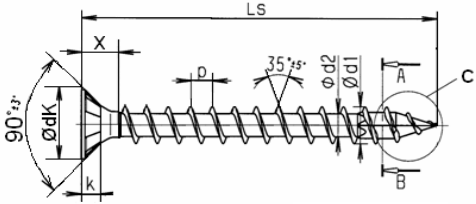

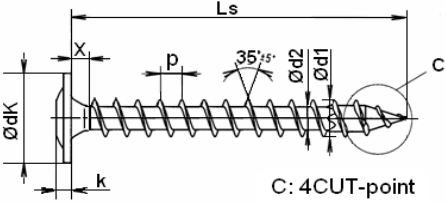
Nominal diameter		6,0						
Type of Head		Countersunk head		Washer head		Cylindric head	Pan head	
d1	thread size	6,0						
	permissible tolerance	±0,20						
dk	head diameter	9,7	11,6	13,0	15,0	8,4	11,9	9,9
	permissible tolerance	-0,60		±1,0		-0,60		
d2	core diameter	4,0						
	permissible tolerance	-0,40						
k	head height max.	4,0	5,0	2,2	2,4	6,0	4,0	3,4
p	thread pitch	3,0						
	permissible tolerance	±0,1 x p						
T-STAR	size			T30			T20	
Thread-free length X	Ls 60-200	max. 15mm						
permissible tolerance of screw length	Ls 60-99	Ls ±2mm						
	Ls 100-200	Ls ±5mm						

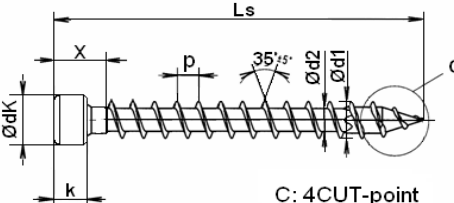

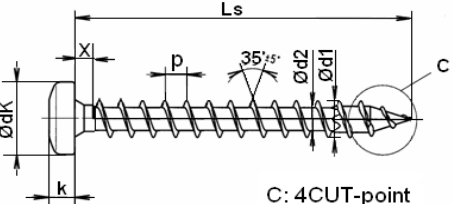
=Preferred size

		Full- thread, self-drilling screw Material: Cold rolled wire according to SPAX - Factory Standard Screws of high-carbon steel
---	---	--

 <p>C: 4CUT-point</p>	Manufacturer's trade mark "SPAX"  T-STAR plus	Cross section A-B  4CUT-point: Square point in core
 <p>C: 4CUT-point</p>	Manufacturer's trade mark "SPAX"  T-STAR plus	
 <p>C: 4CUT-point</p>	 T-STAR plus	
 <p>C: 4CUT-point</p>	Manufacturer's trade mark "SPAX"  T-STAR plus	

Nominal diameter	6,0						
Type of Head	Countersunk head		Washer head		Cylindric head	Pan head	
d1	thread size		6,0				
	permissible tolerance		±0,20				
dk	9,7	11,9	13,0	15,0	8,4	11,9	9,9
	permissible tolerance		±1,0		-0,60		
d2	core diameter		4,0				
	permissible tolerance		-0,40				
k	4,0	5,0	2,2	2,4	6,0	4,0	3,4
p	thread pitch		3,6				
	permissible tolerance		±0,1 x p				
T-STAR plus	size		T30		T20		
Thread-free length X	Ls 60-200		max. 15mm				
permissible tolerance of screw length	Ls 60-99		Ls ±2mm				
	Ls 100-200		Ls ±5mm				

=Preferred size

		Full- thread, self-drilling screw Material: Cold rolled wire according to SPAX - Factory Standard Screws of high-carbon steel
---	---	--

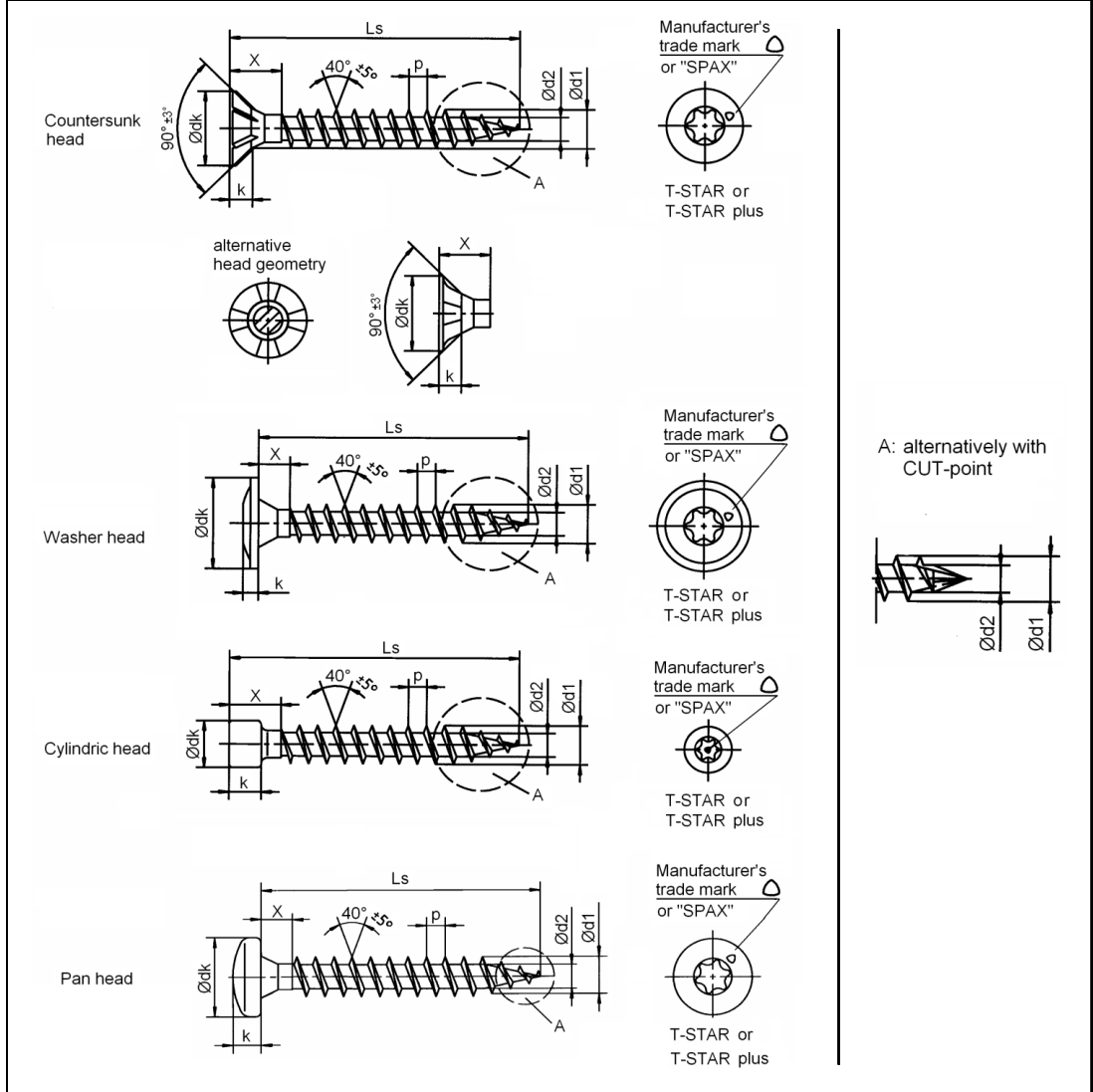

Nominal diameter	8,0									
Type of Head	Countersunk head			Washer head				Cylindric head	Pan head	
d1	thread size									
	permissible tolerance									
dk	head diameter									
	permissible tolerance									
d2	core diameter									
	permissible tolerance									
k	head height max.									
p	thread pitch									
	permissible tolerance									
T - STAR size	T40									
Thread-free length X	Ls 60-200			max. 15mm						
	Ls > 200			max. 25mm						
permissible tolerance of screw length	Ls 60-99			Ls ±2mm						
	Ls 100-200			Ls ±5mm						
	Ls > 200			Ls ±15mm						

Screw lengths Ls up to 600mm (Lengths > 400 mm with cut point) Preferred size

Annex A43

	<h1 style="margin: 0;">SPAX[®]-S</h1>	<p>Full- thread, self-drilling screw</p> <p>Material: Cold rolled wire according to SPAX - Factory Standard</p> <p>Screws of high-carbon steel</p>
---	--	---

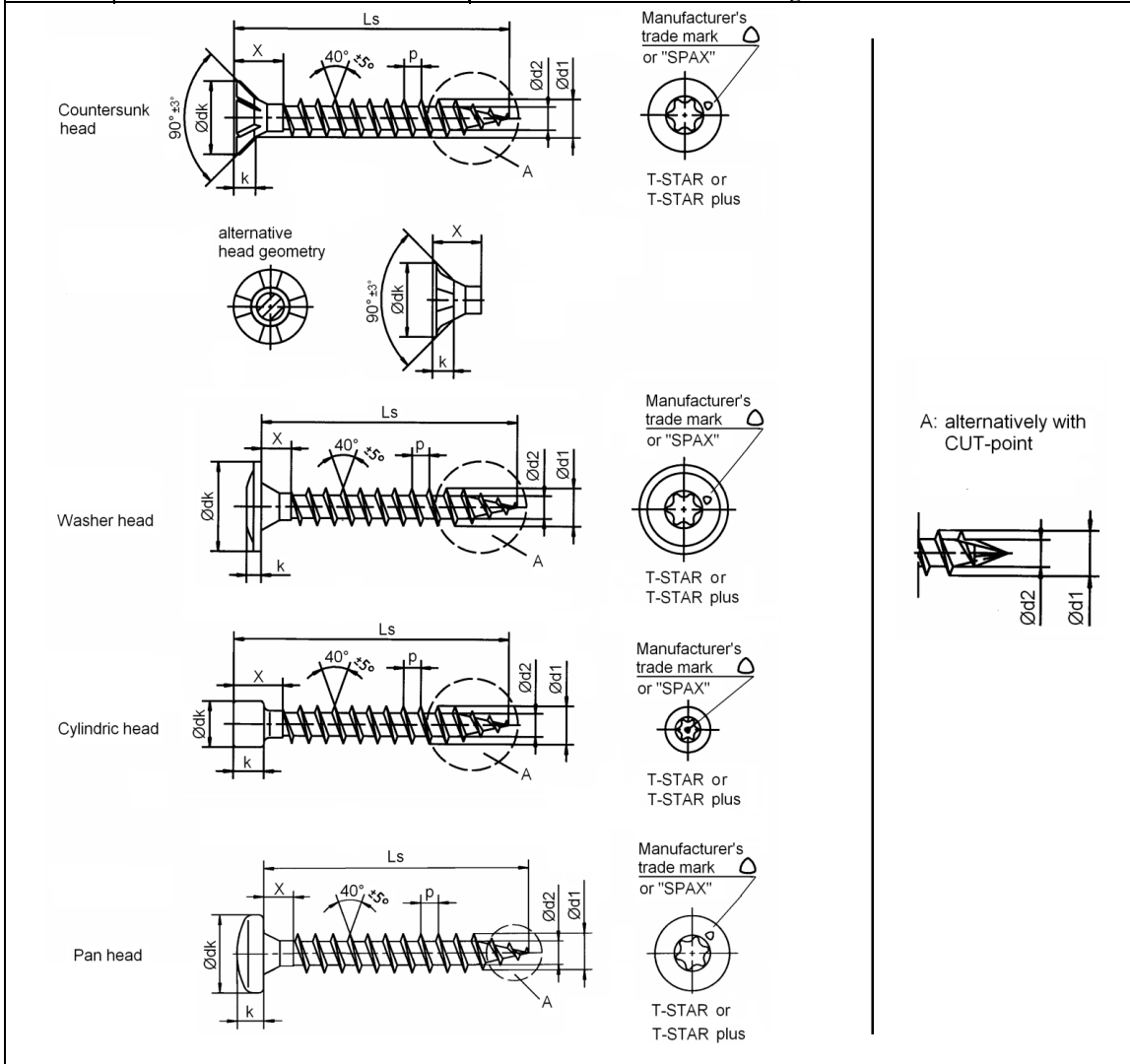

Nominal diameter		10,0						
Type of Head		Countersunk head		Washer head		Cylindric head	Pan head	
d1	thread size	10,0						
	permissible tolerance	±0,30						
dk	head diameter	15,1	18,6	20,0	25,0	12,0	19,0	15,5
	permissible tolerance	-0,60		±1,0		-0,60		
d2	core diameter	6,1						
	permissible tolerance	-0,30						
k	head height max.	4,0	6,0	5,0	5,0	10,0	7,1	5,8
p	thread pitch	5,0						
	permissible tolerance	±0,1 x p						
T - STAR	size	T50		T40		T50	T40	
Thread-free length X	Ls 60-200	max. 15mm						
	Ls > 200	max. 25mm						
permissible tolerance of screw length	Ls 60-99	Ls ±2mm						
	Ls 100-200	Ls ±5mm						
	Ls > 200	Ls ±15mm						

Screw lengths Ls to 800 mm possible = Preferred size

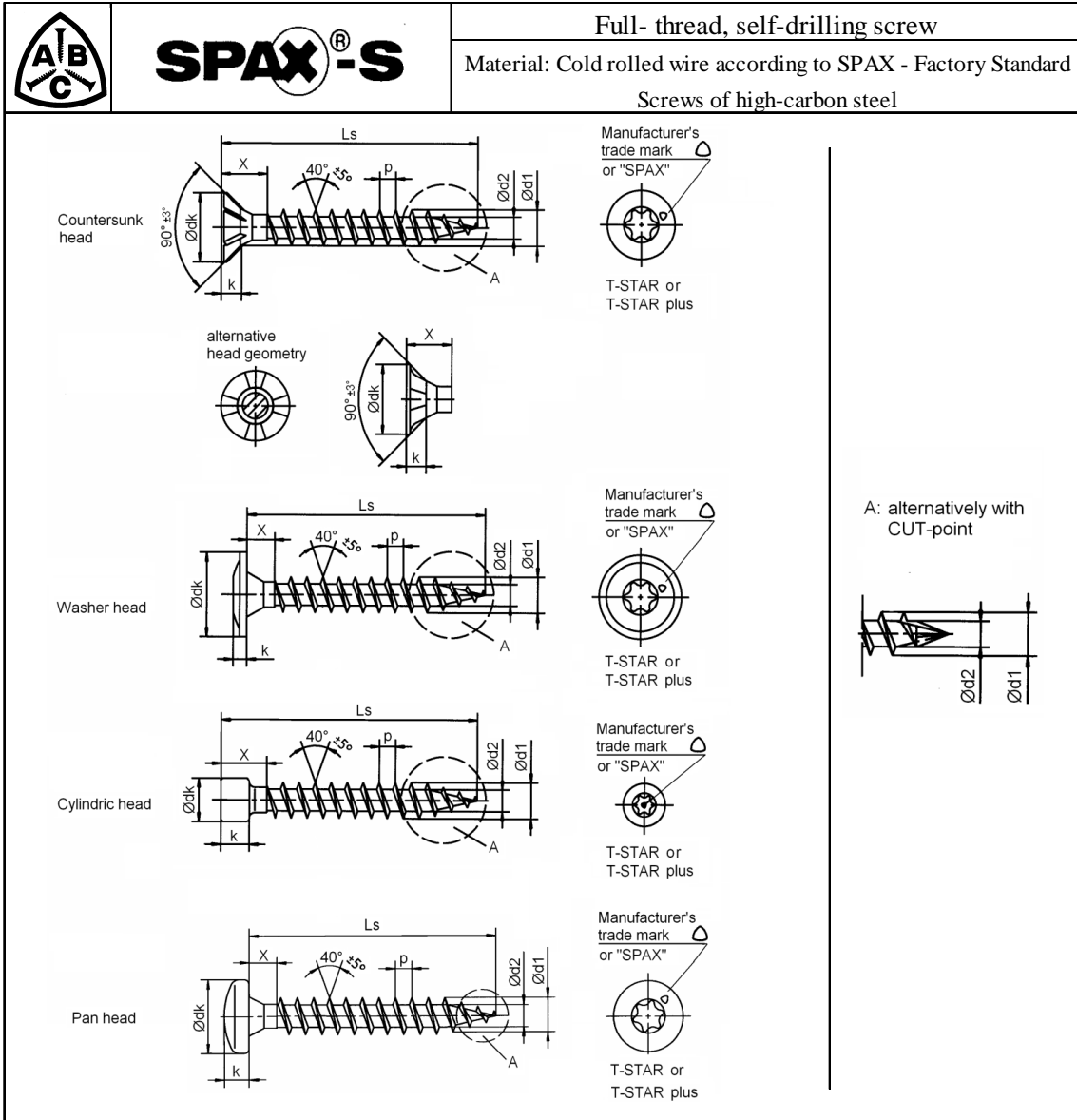

Annex A44



Nominal diameter	12,0						
Type of Head	Countersunk head		Washer head		Cylindric head	Pan head	
d1	thread size		12,0				
	permissible tolerance		±0,30				
dk	head diameter		18,6	22,6	25,0	31,0	14,0 23,0 19,0
	permissible tolerance		-0,60		±1,0		-0,60
d2	core diameter		7,5				
	permissible tolerance		-0,50				
k	head height max.		5,5	7,0	6,0	12,0	8,5 7,1
p	thread pitch		6,0				
	permissible tolerance		±0,1 x p				
T - STAR size			T50				T50
Thread-free length X	Ls 60-99		max. 15mm				
	Ls 100-200		max. 20mm				
	Ls > 200		max. 25mm				
permissible tolerance of screw length	Ls 60-99		Ls ±2mm				
	Ls 100-200		Ls ±10mm				
	Ls > 200		Ls ±15mm				

Screw lengths Ls to 600 mm possible =Preferred size

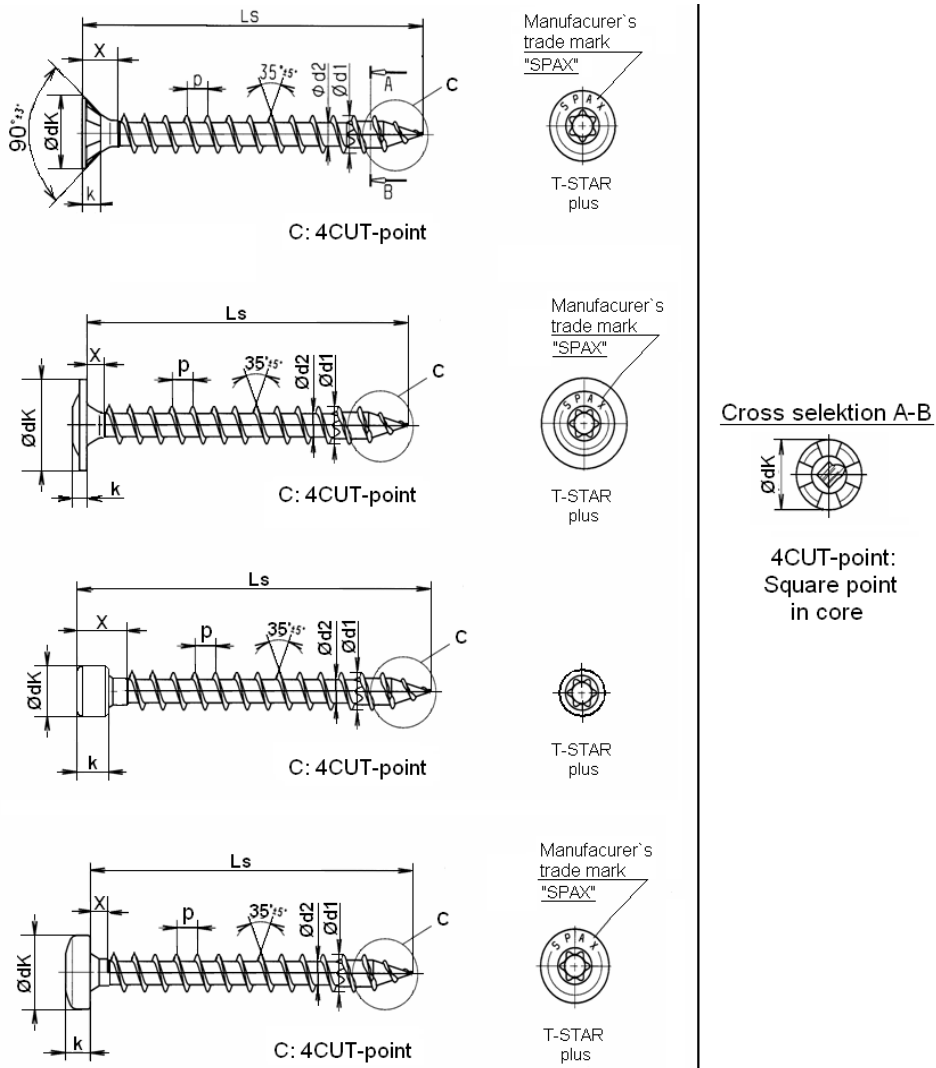

Annex A45

		Full- thread, self-drilling screw Material: Cold rolled wire according to SPAX - Factory Standard Stainless steel screws
---	---	--



Nominal diameter	6,0						
Type of Head	Countersunk head		Washer head		Cylindric head	Pan head	
d1	thread size		6,1				
	permissible tolerance		±0,25				
dk	9,7	11,9	13,0	15,0	8,4	11,9	9,9
	permissible tolerance		±1,0		-0,60		
d2	core diameter		4,0				
	permissible tolerance		+0,1/-0,3				
k	4,0	5,0	2,2	2,4	6,0	4,0	3,4
p	thread pitch		3,6				
	permissible tolerance		±0,1 x p				
T-STAR plus	size		T30		T20		
Thread-free length X	Ls 60-200		max. 15mm				
permissible tolerance of screw length	Ls 60-99		Ls ±2mm				
	Ls 100-200		Ls ±5mm				

=Preferred size

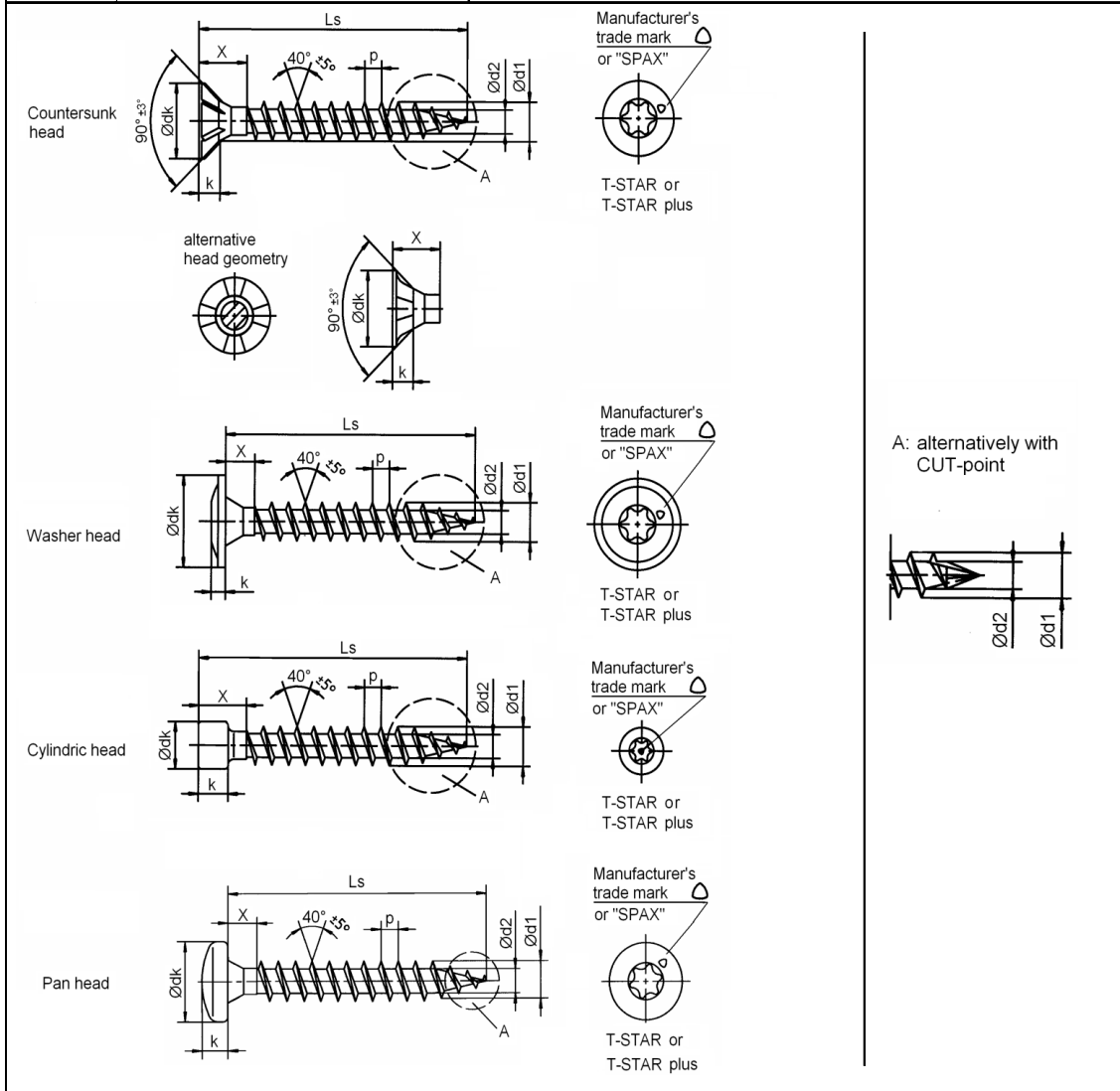

		Full- thread, self-drilling screw Material: Cold rolled wire according to SPAX Factory - Standard Stainless steel screws
---	---	---



Nominal diameter		8,0								
Type of Head		Countersunk head			Washer head			Cylindric head		Pan head
d1	thread size	8,0								
	permissible tolerance	±0,30								
dk	head diameter	12,0	15,1	18,0	20,0	22,0	24,0	10,0	15,5	11,9
	permissible tolerance	±1,0								
d2	core diameter	5,0								
	permissible tolerance	-0,30								
k	head height max.	4,0	5,0				4,5	8,0	5,8	4,0
p	thread pitch	4,0								
	permissible tolerance	±0,1 x p								
T - STAR	size							T40		T30
Thread-free length X	Ls 60-200	max. 15mm								
	Ls > 200	max. 25mm								
permissible tolerance of screw length	Ls 60-99	Ls ±2mm								
	Ls 100-200	Ls ±5mm								
	Ls > 200	Ls ±15mm								

Screw lengths Ls up to 600mm (Lengths > 400 mm with cut point) =Preferred size

Annex A47

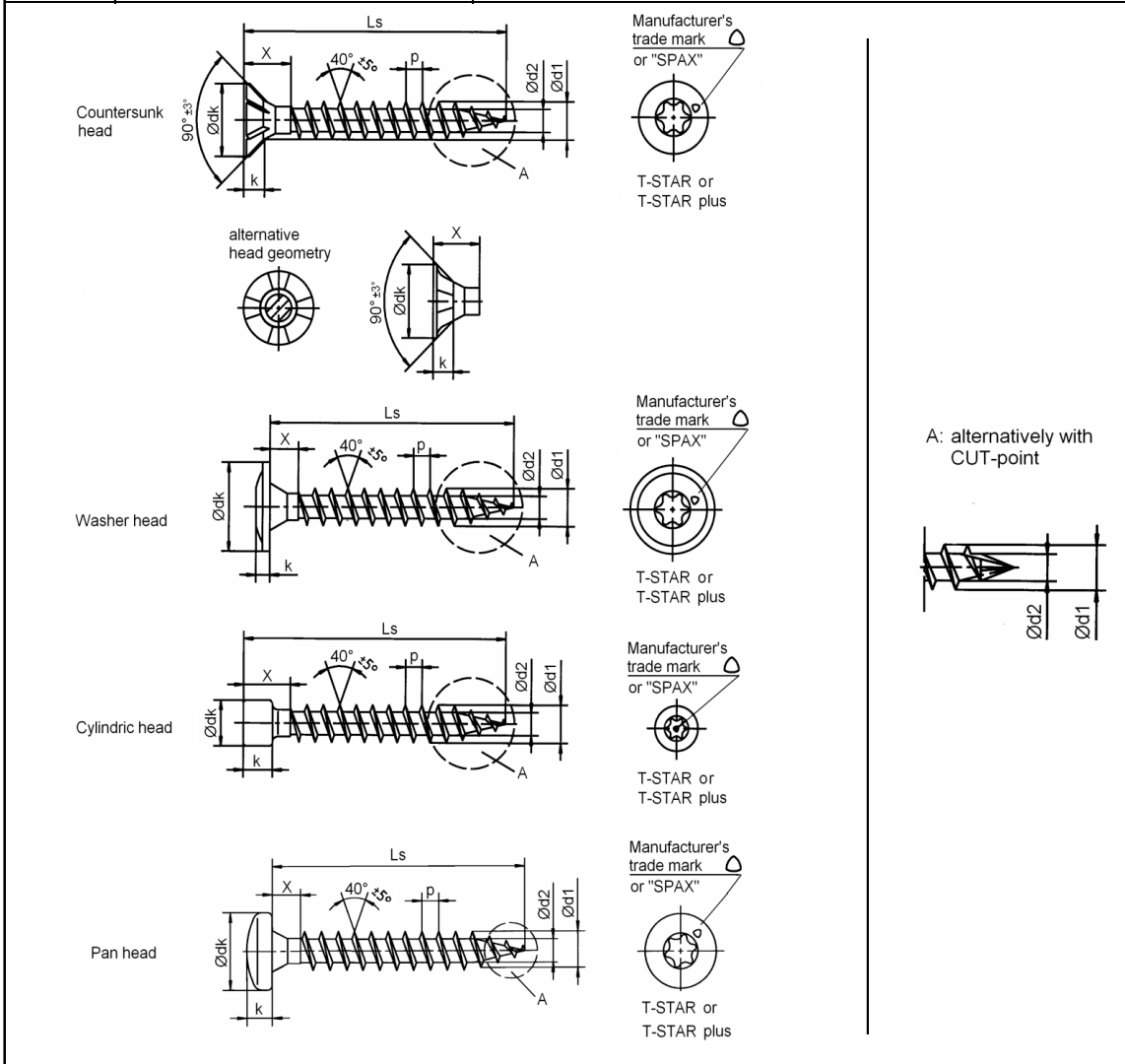

		<p>Full- thread, self-drilling screw</p> <p>Material: Cold rolled wire according to SPAX - Factory Standard</p> <p>Stainless steel screws</p>
---	---	---



Nominal diameter		10,0						
Type of Head		Countersunk head		Washer head		Cylindric head	Pan head	
d1	thread size	10,0						
	permissible tolerance	±0,40						
dk	head diameter	15,1	18,6	20,0	25,0	12,0	19,0	16
	permissible tolerance	±1,0						
d2	core diameter	6,1						
	permissible tolerance	-0,30						
k	head height max.	4,0	6,0	5,0	5,0	10,0	7,1	5,8
p	thread pitch	5,0						
	permissible tolerance	±0,1 x p						
T - STAR	size	T50		T40		T50	T40	
Thread-free length X	Ls 60-200	max. 15mm						
	Ls > 200	max. 25mm						
permissible tolerance of screw length	Ls 60-99	Ls ±2mm						
	Ls 100-200	Ls ±5mm						
	Ls > 200	Ls ±15mm						

Screw lengths Ls to 800 mm possible = Preferred size

Annex A48

		<p>Full- thread, self-drilling screw</p> <p>Material: Cold rolled wire according to SPAX - Factory Standard</p> <p>Stainless steel screws</p>
---	---	---

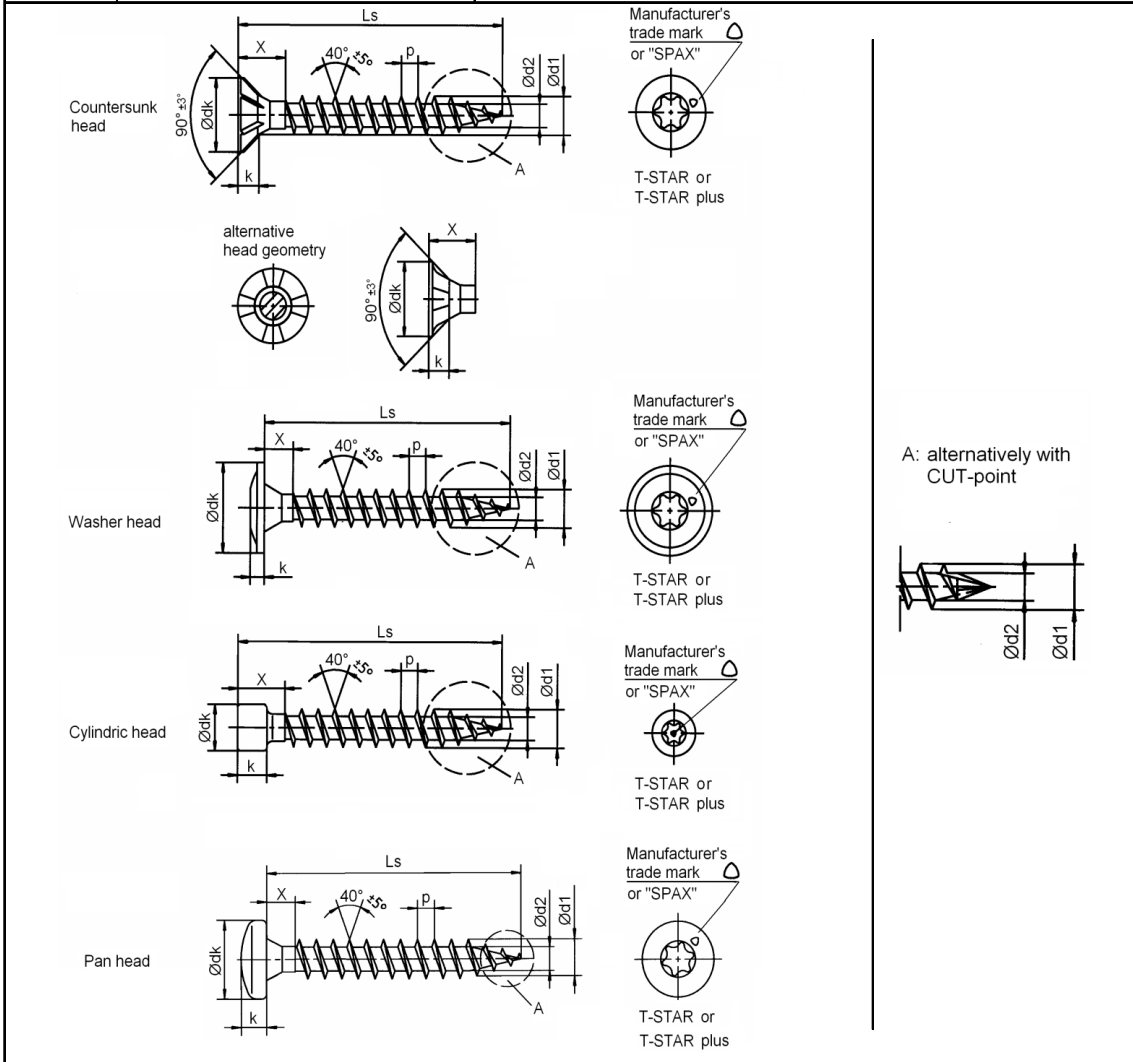

Nominal diameter	12,0						
Type pf Head	Countersunk head		Washer head		Cylindric head	Pan head	
d1	12,0						
	permissible tolerance ±0,40						
dk	18,6	22,6	25,0	31,0	14,0	23,0	19,0
	permissible tolerance ±1,0						
d2	7,5						
	permissible tolerance -0,50						
k	5,5	7,0	6,0		12,0	8,5	7,1
p	6,0						
	permissible tolerance ±0,1 x p						
T - STAR size	T50					T50	
Thread-free length X	Ls 60-99	max. 15mm					
	Ls 100-200	max. 20mm					
	Ls > 200	max. 25mm					
permissible tolerance of screw length	Ls 60-99	Ls ±2mm					
	Ls 100-200	Ls ±10mm					
	Ls > 200	Ls ±15mm					

Screw lengths Ls to 600 mm possible =Preferred size

Annex A49



SPAX®-S

Hex. head with/without flange

Full- thread, self-drilling screw

Material: Cold rolled wire according to SPAX - Factory Standard

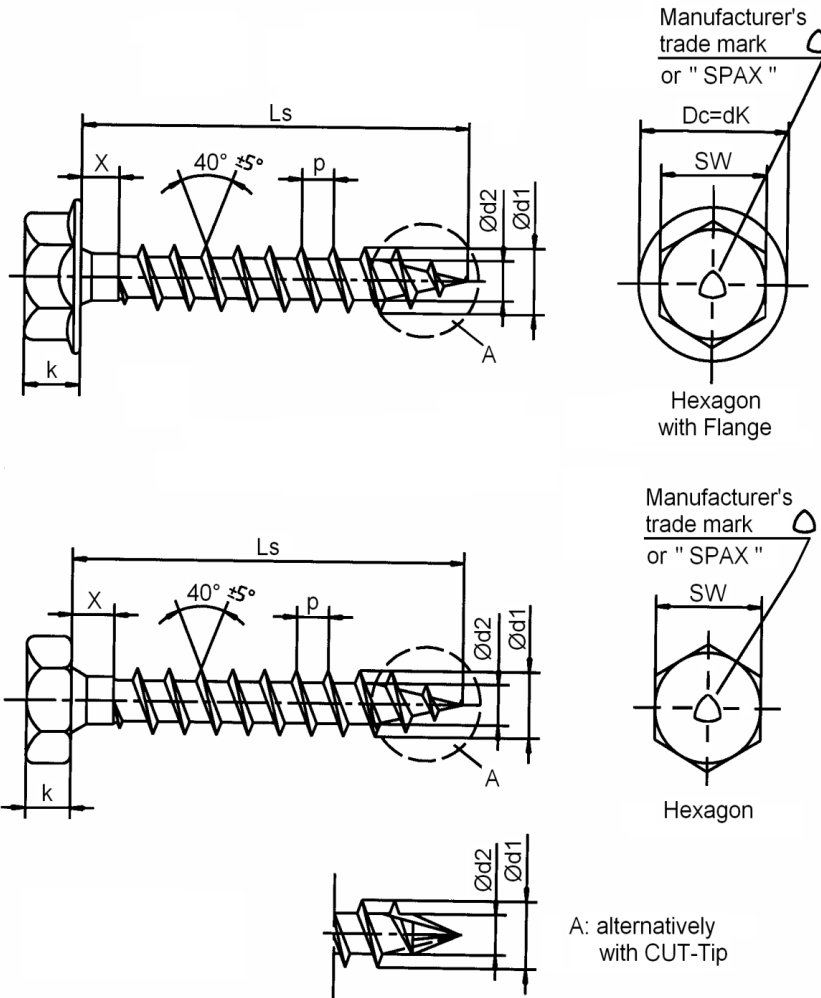

Screws of high-carbon steel



Nominal diameter	8,0		10,0		12,0		
Type of Head	without flange	with flange	without flange	with flange	without flange	with flange	
SW wrench size	10		13		16		
k head height max.	6,00	8,5	7,00	9,7	8,00	12,1	
Dc diameter of flange	15,5		19,5		22,5		
permissible tolerance			±1				
d1 thread diameter	8,0		10,0		12,0		
permissible tolerance			±0,30				
d2 core diameter	5,0		6,1		7,5		
permissible tolerance			-0,30		-0,50		
p thread pitch	4,0		5,0		6,0		
permissible tolerance			±0,1 x p				
thread-free length X	Ls 60-99	max. 15mm		max. 15mm		max. 15mm	
	Ls 100-200					max. 20mm	
	Ls > 200	max. 25mm		max. 25mm		max. 25mm	
permissible tolerance of screw length	Ls 60-99	Ls ±2mm				Ls ±2mm	
	Ls 100-200	Ls ±5mm				Ls ±10mm	
	Ls > 200	Ls ±15mm				Ls ±15mm	

Screw lengths Ls up to 600mm possible (at a nominal diameter of 8,0mm lengths > 400mm with CUT-point)

Annex A50

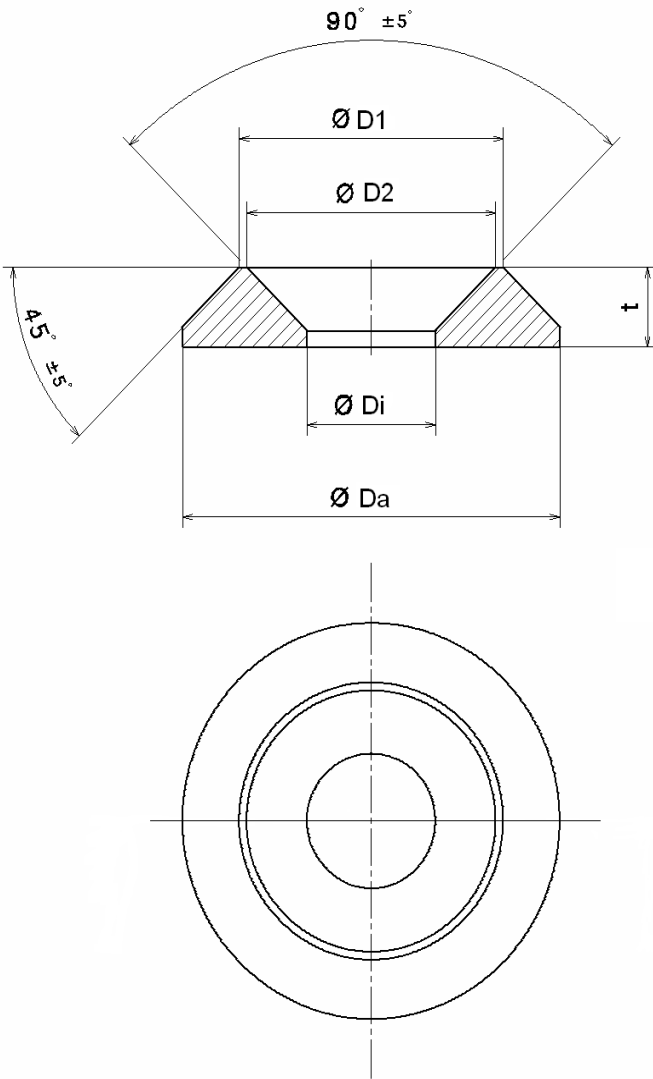
	 Washer	Washer for screws with countersunk and raised countersunk head				
		Material: machining steel				
Dimensions in mm						
						
Thread size	6,0	8,0	10,0	12,0	Tolerance	
ØDa	18,0	25,0	32,0	40,0	± 0,3	
ØDi	6,5	8,5	11,0	13,0		
ØD1	13,5	17,5	22,5	27,0		
ØD2	12,5	16,5	21,5	26,0		
t	3,5	5,0	5,6	7,0		
Annex A51						



Threaded rod with full thread

Material: Steel or Stainless steel

Design with hexagon head

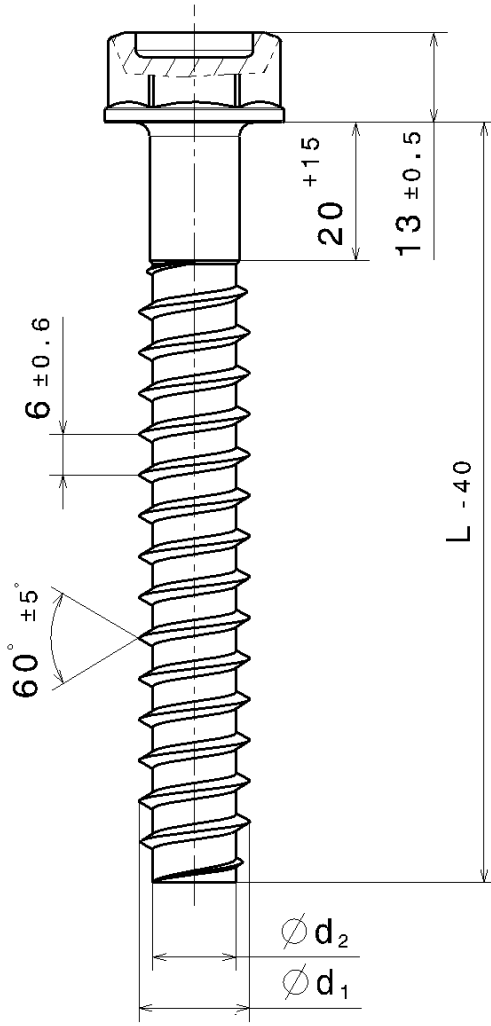

L
800
1000
1200
1400
1600
1800
2000
2200

Manufacturer's trade mark:
ABC or SPAX

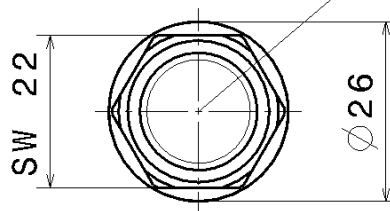

Stainless steel	16 ^{+0.2} _{-0.7}	12 ^{+0.2} _{-0.5}
Steel	16 ^{+0.2} _{-0.7}	12 ^{+0.2} _{-0.4}
	Ø d ₁	Ø d ₂

- Other lengths 100 - 3000 mm possible
- Length can be changed by cutting the threaded part



SPAX®

Threaded rod with full thread

Material: Steel or Stainless steel

Design without head



Screw adapter
available as accessory

L
3000

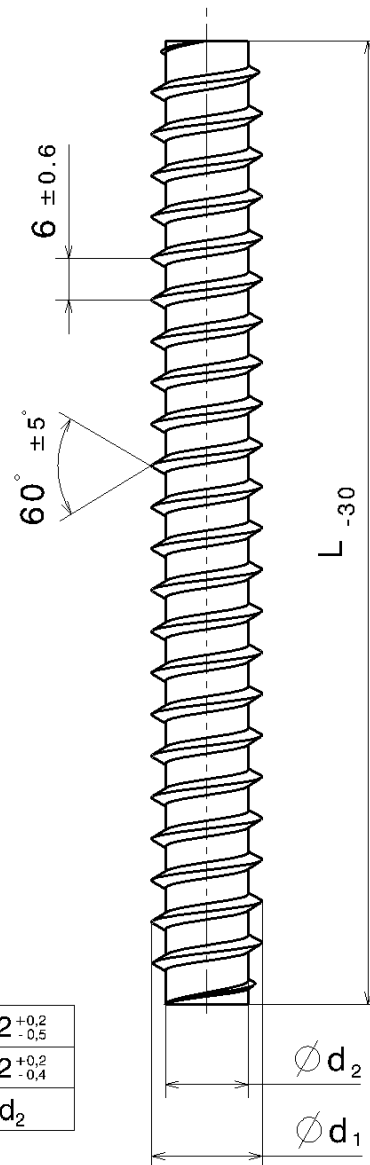

Stainless steel	16 ^{+0,2} _{-0,7}	12 ^{+0,2} _{-0,5}
Steel	16 ^{+0,2} _{-0,7}	12 ^{+0,2} _{-0,4}
	Ø d ₁	Ø d ₂

- Other lengths 100 - 3000 mm possible
- Length can be changed by cutting the threaded part

Annex B Minimum distances and spacing

Minimum distances and spacing for exclusively axially loaded SPAX screws with CUT or 4CUT drill tip or with $d \leq 8$ mm in non-predrilled holes in members of solid timber, glued laminated timber or similar glued products

Single configuration

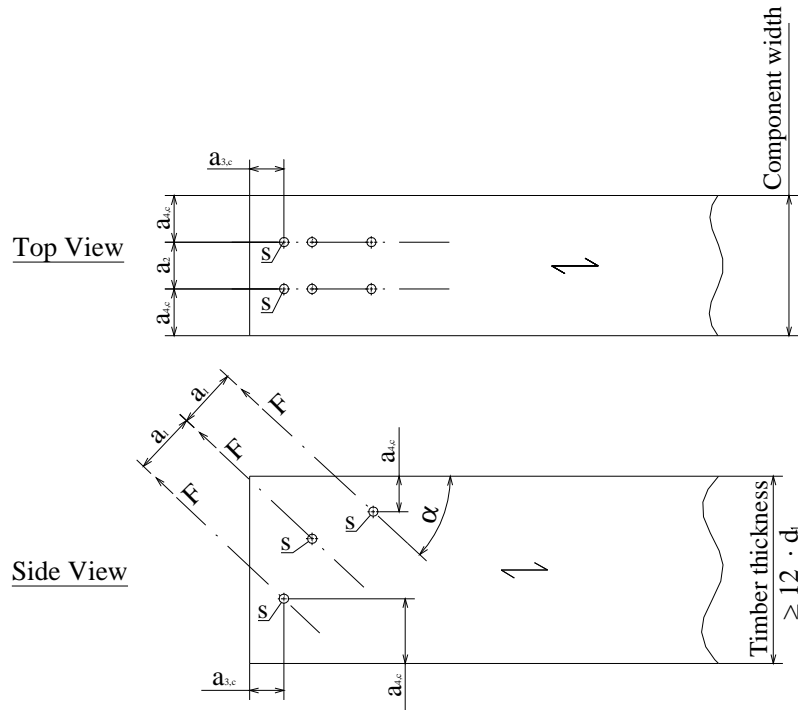

↔ grain direction

--- screw axis

S centroid of the part of the screw in the timber

$15^\circ \leq \alpha \leq 90^\circ$

$$a_1 \geq 5 \cdot d$$

$$a_2 \geq 2,5 \cdot d$$

$$a_{3,c} \geq 5 \cdot d$$

$$a_{4,c} \geq 4 \cdot d$$

$$\geq 3 \cdot d \quad \text{for screws with CUT or 4CUT drill tip}$$

$$a_1 \cdot a_2 \geq 25 \cdot d^2$$

Minimum distances and spacing see also 4.2

Minimum timber thickness $t = 12 \cdot d$ for solid or glued laminated timber and $t = 6 \cdot d$ for laminated veneer lumber, see also 4.2

Minimum distances and spacing for exclusively axially loaded SPAX screws with CUT or 4CUT drill tip or with $d \leq 8$ mm in non-predrilled holes in members of solid timber, glued laminated timber or similar glued products

Crosswise configuration

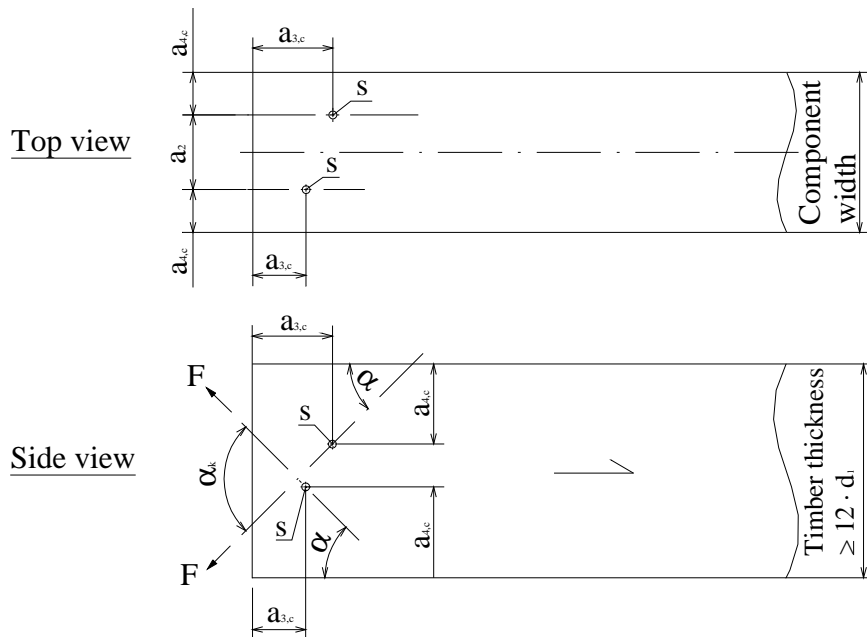

\leftarrow grain direction

- - - screw axis

S centroid of the part of the screw in the timber

$15^\circ \leq \alpha \leq 90^\circ$

$$a_1 \geq 5 \cdot d$$

$$a_2 \geq 1,5 \cdot d \quad \text{for } 70^\circ < \alpha_k \leq 90^\circ$$

$$\geq 2,5 \cdot d \cdot (1 - \alpha_k / 180^\circ) \quad \text{for } 30^\circ \leq \alpha_k \leq 70^\circ$$

$$a_{3,c} \geq 5 \cdot d$$

$$a_{4,c} \geq 4 \cdot d$$

$$\geq 3 \cdot d$$

for screws with CUT or 4CUT drill tip

$$a_1 \cdot a_2 \geq 25 \cdot d^2$$

Minimum distances and spacing see also 4.2

Minimum timber thickness $t = 12 \cdot d$ for solid or glued laminated timber and $t = 6 \cdot d$ for laminated veneer lumber, see also 4.2

Mechanically jointed beams

SPAX screws with a full thread or threaded rods may be used for connections in structural members which are composed of several parts in mechanically jointed beams or columns.

The axial slip modulus K_{ser} of a screw or threaded rod with a full thread for the serviceability limit state should be taken independent of angle α to the grain as:

$$C = K_{ser} = 780 \cdot d^{0,2} \cdot \ell_{ef}^{0,4} \quad [\text{N/mm}] \text{ for screws or threaded rods in softwood}$$

Where

d outer thread diameter [mm]

ℓ_{ef} penetration length in the structural member [mm]

Axially loaded SPAX screws or threaded rods in solid or glued laminated timber or laminated veneer lumber

Single configuration

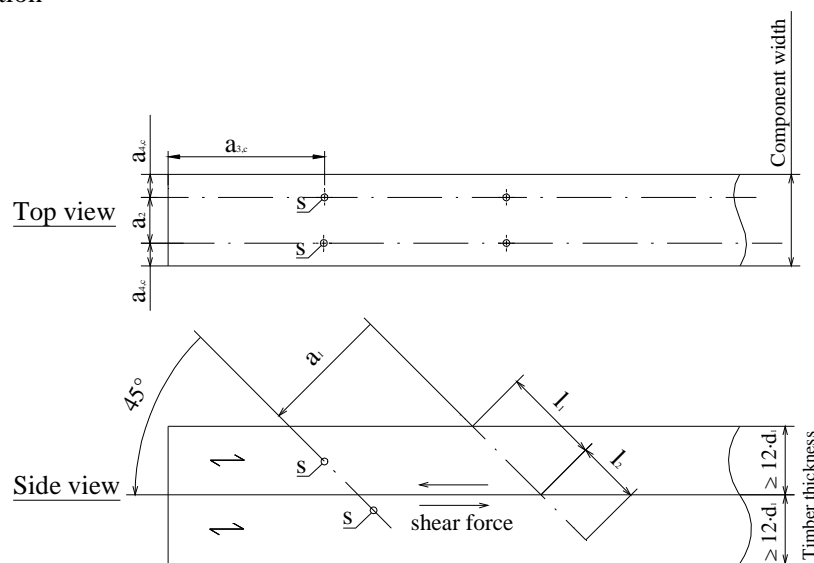

\leftarrow grain direction

--- screw axis

S centroid of the part of the screw in the timber

$$a_1 \geq 5 \cdot d$$

$$a_2 \geq 2,5 \cdot d$$

$$a_{3,c} \geq 5 \cdot d$$

$$a_{4,c} \geq 4 \cdot d$$

$$\geq 3 \cdot d \quad \text{for screws with CUT or 4CUT drill tip}$$

$$a_1 \cdot a_2 \geq 25 \cdot d^2$$

Minimum distances and spacing see also 4.2

Minimum timber thickness $t = 12 \cdot d$ for solid or glued laminated timber and $t = 6 \cdot d$ for laminated veneer lumber, see also 4.2

Axially loaded SPAX screws or threaded rods in solid or glued laminated timber or laminated veneer lumber
 Crosswise configuration

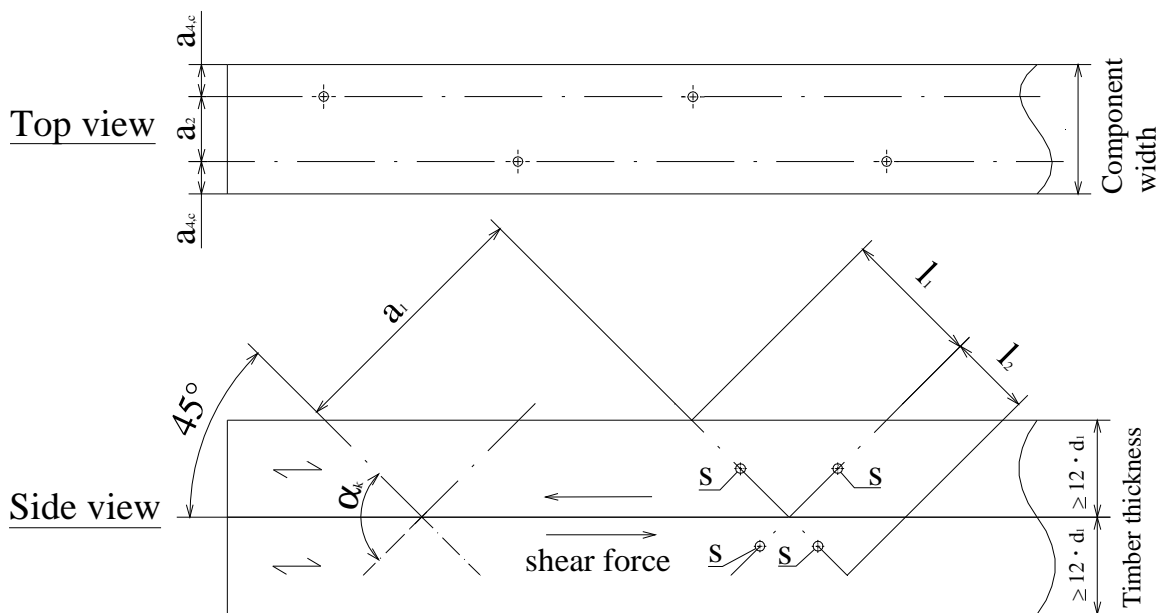

- \leftarrow grain direction
- - - screw axis
- S centroid of the part of the screw in the timber

$$a_1 \geq 5 \cdot d$$

$$a_2 \geq 2,5 \cdot d \quad (a_2 \geq 1,5 \cdot d \text{ between the crossing screws of a screw couple})$$

$$a_{3,c} \geq 5 \cdot d$$

$$a_{4,c} \geq 4 \cdot d$$

$$\geq 3 \cdot d \quad \text{for screws with CUT or 4CUT drill tip}$$

$$a_1 \cdot a_2 \geq 25 \cdot d^2$$

Minimum distances and spacing see also 4.2

Minimum timber thickness $t = 12 \cdot d$ for solid or glued laminated timber and $t = 6 \cdot d$ for laminated veneer lumber, see also 4.2

Axially or laterally loaded screws in the plane or edge surface of cross laminated timber

Definition of spacing, end and edge distances in the plane surface unless otherwise specified in the technical specification (ETA or hEN) for the cross laminated timber:

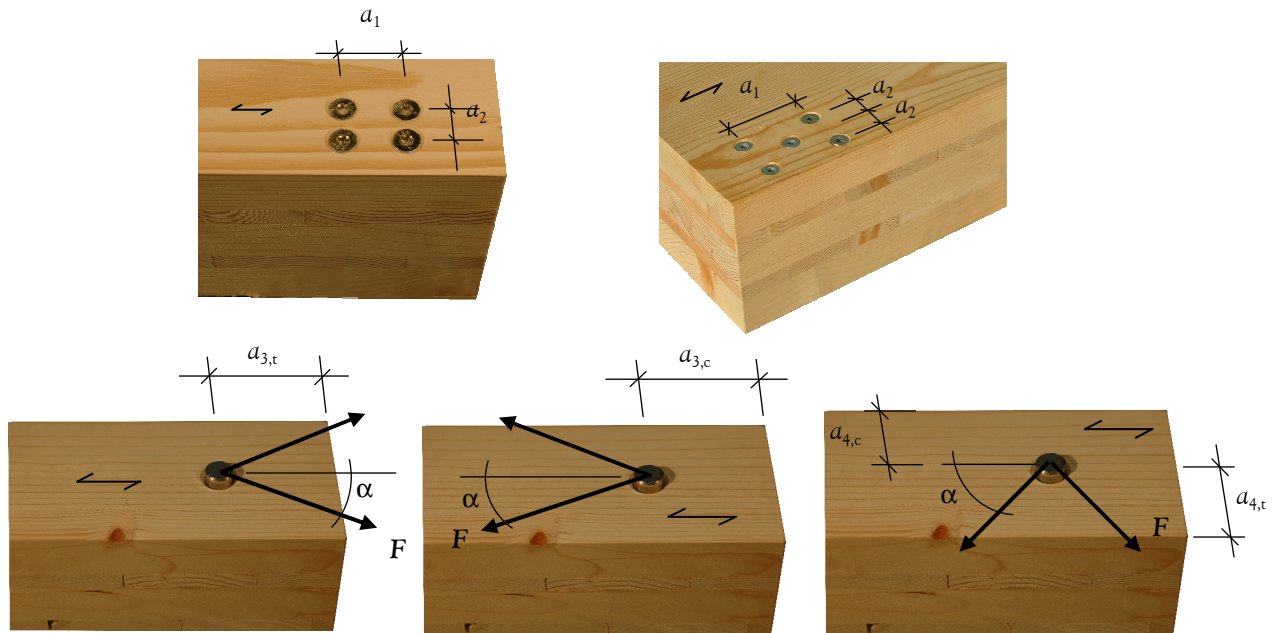

Definition of spacing, end and edge distances in the edge surface unless otherwise specified in the technical specification (ETA or hEN) for the cross laminated timber:

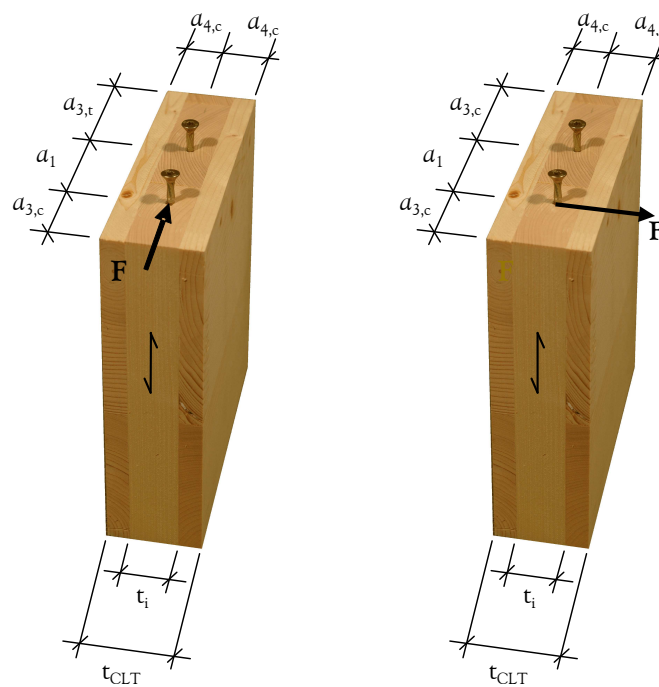

Annex C

Compression reinforcement

SPAX screws or threaded rods with a full thread may be used for reinforcement of timber members with compression stresses at an angle α to the grain of $45^\circ \leq \alpha \leq 90^\circ$. The compression force must be evenly distributed over all screws.

The characteristic load-carrying capacity for a contact area with screws with a full thread at an angle α to the grain of $45^\circ \leq \alpha \leq 90^\circ$ shall be calculated from:

$$F_{90,Rk} = \min \begin{cases} k_{c,90} \cdot B \cdot \ell_{ef,1} \cdot f_{c,90,k} + n \cdot F_{ax,Rk} \\ B \cdot \ell_{ef,2} \cdot f_{c,90,k} \end{cases}$$

Where

$F_{90,Rk}$ Load-carrying capacity of reinforced contact area [N]

$k_{c,90}$ factor for compression perpendicular to the grain according to EN 1995-1-1

B bearing width [mm]

$\ell_{ef,1}$ effective length of contact area according to EN 1995-1-1 [mm]

$f_{c,90,k}$ characteristic compressive strength perpendicular to the grain [N/mm²]

n number of reinforcement screws, $n = n_0 \cdot n_{90}$

n_0 number of reinforcement screws arranged in a row parallel to the grain

n_{90} number of reinforcement screws arranged in a row perpendicular to the grain

$F_{ax,Rk}$ characteristic compressive capacity [N]

$\ell_{ef,2}$ effective distribution length in the plane of the screw tips [mm]

$$\ell_{ef,2} = \ell_{ef} + (n_0 - 1) \cdot a_1 + \min(\ell_{ef}; a_{3,c})$$

for end-bearings [mm]

$$\ell_{ef,2} = 2 \cdot \ell_{ef} + (n_0 - 1) \cdot a_1 \text{ for centre-bearings [mm]}$$

ℓ_{ef} point side penetration length [mm]

a_1 spacing parallel to the grain [mm]

$a_{3,c}$ end distance [mm]

Reinforcing screws or threaded rods for wood-based panels are not covered by this European Technical Approval.

Reinforced centre-bearing

- H component height [mm]
- B bearing width [mm]
- l_{ef} point side penetration length [mm]
- $l_{ef,2}$ effective distribution length in the plane of the screw tips [mm]
 $= 2 \cdot l_{ef} + (n_0 - 1) \cdot a_1$ for centre-bearings

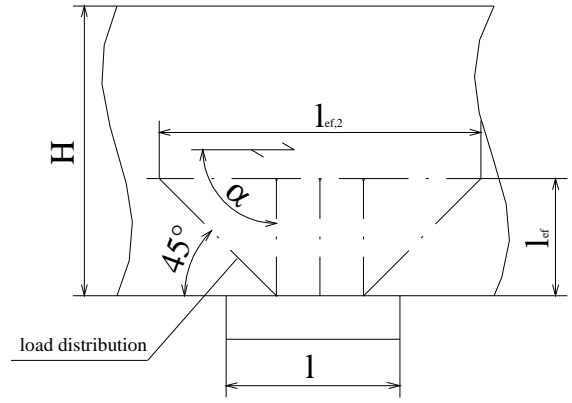

- grain direction
- screw axis
- $45^\circ \leq \alpha \leq 90^\circ$

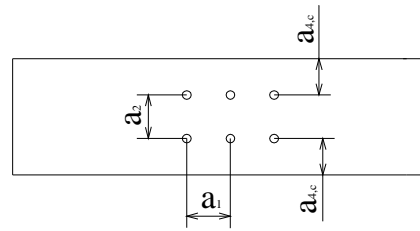

Reinforced end-bearing

- H component height [mm]
- B bearing width [mm]
- l_{ef} point side penetration length [mm]
- $l_{ef,2}$ effective distribution length in the plane of the screw tips [mm]
 $= l_{ef} + (n_0 - 1) \cdot a_1 + \min(l_{ef}, a_{3,c})$ for end-bearings

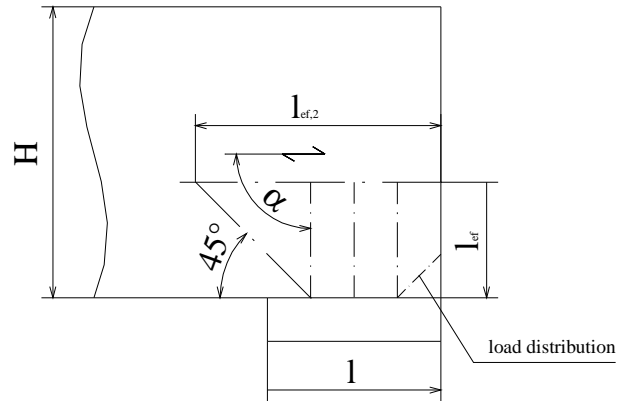

- grain direction
- screw axis
- $45^\circ \leq \alpha \leq 90^\circ$

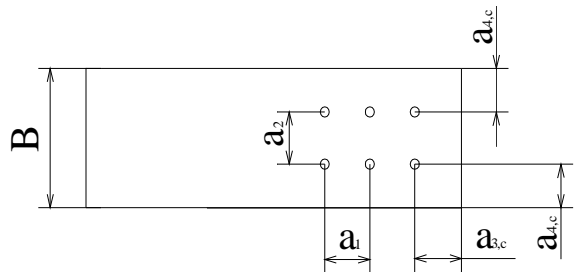

- $a_1 \geq 5 \cdot d$
- $a_2 \geq 2,5 \cdot d$
- $a_{3,c} \geq 5 \cdot d$
- $a_{4,c} \geq 4 \cdot d$
- $\geq 3 \cdot d$ for screws with CUT or 4CUT drill tip
- $a_1 \cdot a_2 \geq 25 \cdot d^2$

Annex D Tensile reinforcement perpendicular to grain

Unless specified otherwise in national provisions that apply at the installation site, the axial capacity of a reinforcement of a timber member loaded by a connection force perpendicular to the grain shall fulfil the following condition:

$$\frac{[1 - 3 \cdot \alpha^2 + 2 \cdot \alpha^3] \cdot F_{90,d}}{F_{ax,Rd}} \leq 1$$

Where

$F_{90,d}$ Design value of the force component perpendicular to the grain,

$\alpha = a/h$

$h =$ member depth

$F_{ax,Rd}$ Minimum of the design values of the withdrawal capacity and the tensile capacity of the reinforcing screws or threaded rods where ℓ_{ef} is the smaller value of the penetration depth below or above the potential crack

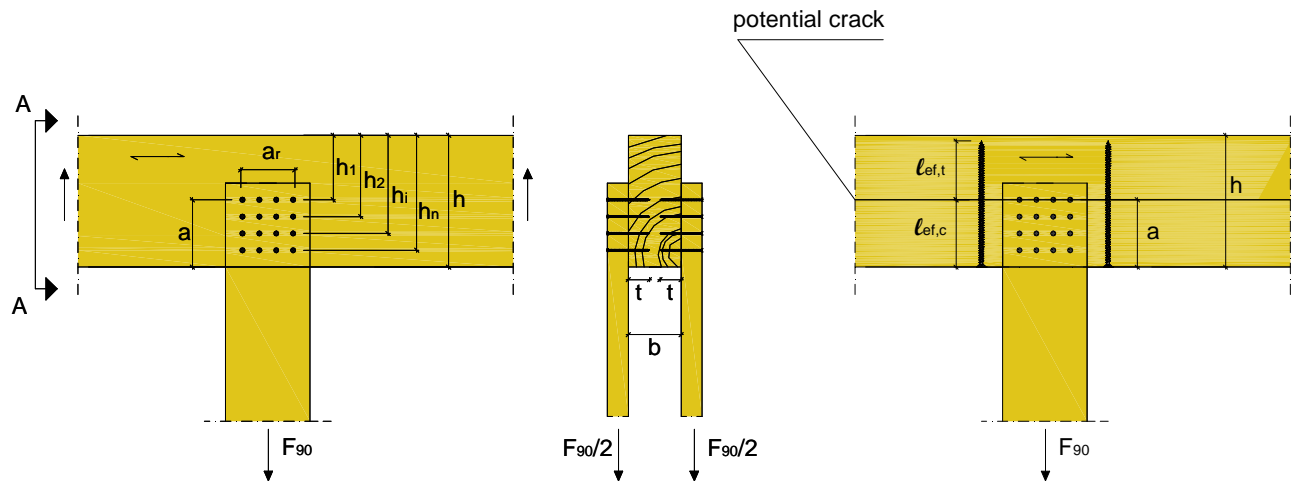

Unless specified otherwise in national provisions that apply at the installation site, the axial capacity of a reinforcement of a notched beam support shall fulfil the following condition:

$$\frac{1,3 \cdot V_d \cdot [3 \cdot (1 - \alpha)^2 - 2 \cdot (1 - \alpha)^3]}{F_{ax,Rd}} \leq 1$$

Where

V_d Design value of the shear force,

$\alpha = h_o/h$

$h =$ member depth

$F_{ax,Rd}$ Minimum of the design values of the withdrawal capacity and the tensile capacity of the reinforcing screws or threaded rods where ℓ_{ef} is the smaller value of the penetration depth below or above the potential crack

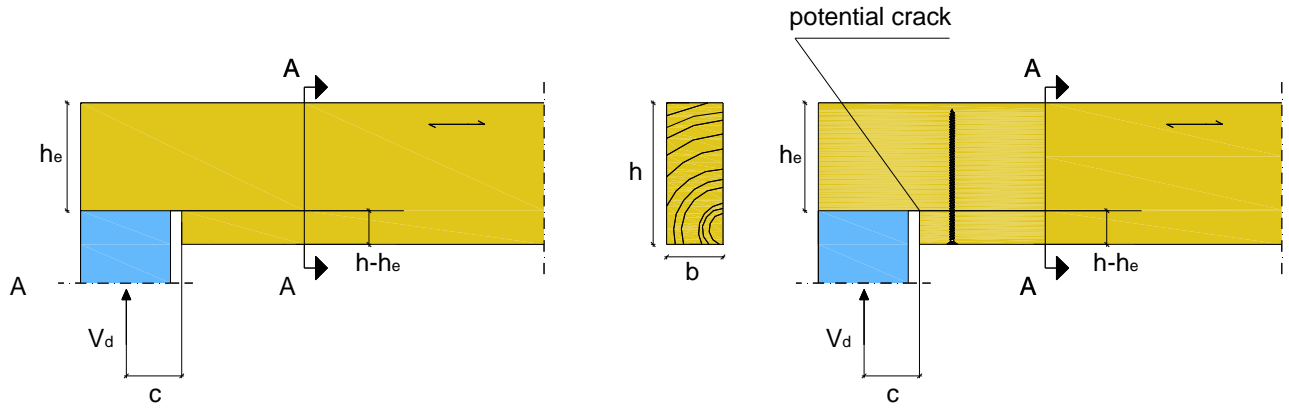

Unless specified otherwise in national provisions that apply at the installation site, the axial capacity of a reinforcement of a hole in a beam shall fulfil the following condition:

$$\frac{F_{t,V,d} + F_{t,M,d}}{F_{ax,Rd}} \leq 1$$

Where

$F_{t,V,d}$ Design value of the force perpendicular to the grain due to shear force:

$$F_{t,V,d} = \frac{V_d \cdot h_d}{4 \cdot h} \cdot \left[3 - \frac{h_d^2}{h^2} \right]$$

V_d Design value of the member shear force at the hole end,

h = member depth

h_d = hole depth for rectangular holes

h_d = 70 % of hole diameter for circular holes

$F_{t,M,d}$ Design value of the force perpendicular to the grain due to bending moment:

$$F_{t,M,d} = 0,008 \cdot \frac{M_d}{h_r}$$

M_d Design value of the member bending moment at the hole end,

h_r = $\min(h_{ro}; h_{ru})$ for rectangular holes

h_r = $\min(h_{ro}; h_{ru}) + 0,15 \cdot h_d$ for circular holes

$F_{ax,Rd}$ Minimum of the design values of the withdrawal capacity and the tensile capacity of the reinforcing screws or threaded rods where ℓ_{ef} is the smaller value of the penetration depth below or above the potential crack.

It shall be emphasized that beside the reinforcement with screws also a strength verification is required for the shear strength of the timber in the vicinity of the hole

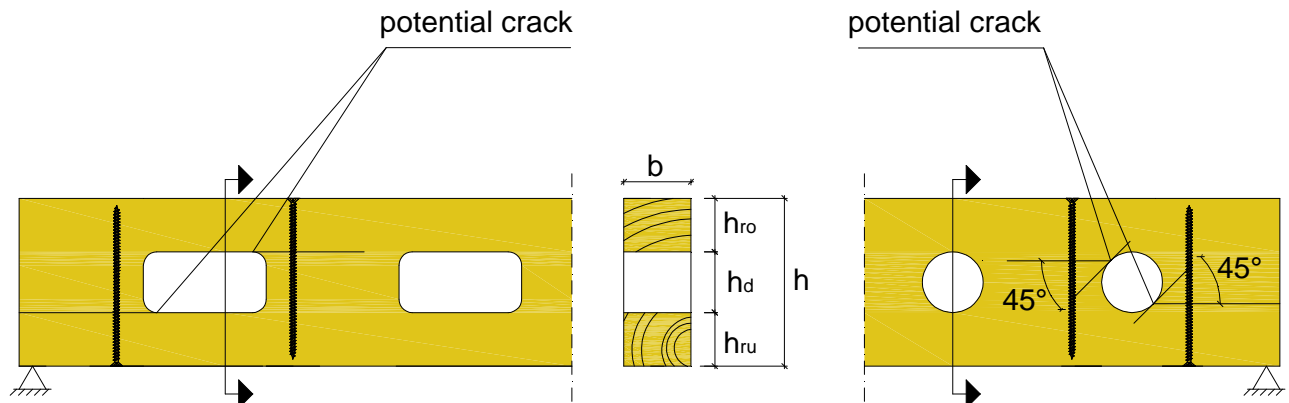

Annex E

Shear reinforcement

Unless specified otherwise in national provisions that apply at the installation site, the shear stress in reinforced areas of timber members with a stress component parallel to the grain shall fulfil the following condition:

$$\tau_d \leq \frac{f_{v,d} \cdot k_\tau}{\eta_H}$$

Where:

τ_d is the design shear stress disregarding the reinforcement;

$f_{v,d}$ is the design shear strength;

$$k_\tau = 1 - 0,46 \cdot \sigma_{90,d} - 0,052 \cdot \sigma_{90,d}^2$$

$\sigma_{90,d}$ is the design stress perpendicular to the grain (negative value for compression);

$$\sigma_{90,d} = \frac{F_{ax,d}}{\sqrt{2} \cdot b \cdot a_1}$$

$$F_{ax,d} = \frac{\sqrt{2} \cdot (1 - \eta_H) \cdot V_d \cdot a_1}{h}$$

$$\eta_H = \frac{G \cdot b}{G \cdot b + \frac{1}{2 \cdot \sqrt{2} \left(\frac{6}{\pi \cdot d \cdot h \cdot k_{ax}} + \frac{a_1}{EA_S} \right)}}$$

V_d is the design shear force;

G is the shear modulus of the timber member, $G = 650 \text{ N/mm}^2$,

b is the width of the timber member in mm,

d is the outer thread diameter in mm, (d_1 in the drawings in the annex)

h is the depth of the timber member in mm,

k_{ax} is the connection stiffness between rod or screw and timber member in N/mm^3 ,

$k_{ax} = 5 \text{ N/mm}^3$ for threaded rods $d = 16 \text{ mm}$, $k_{ax} = 12,5 \text{ N/mm}^3$ for self-tapping screws $d = 8 \text{ mm}$,

a_1 is the spacing parallel to the grain of the rods or screws arranged in one row in mm,

EA_S is the axial stiffness of one rod or screw,

$$EA_S = \frac{E \cdot \pi \cdot d_2^2}{4} = 165.000 d_2^2,$$

d_2 is the inner thread diameter of the rod or screw,

$d_2 = 12 \text{ mm}$ for threaded rods $d = 16 \text{ mm}$, $d_2 = 5 \text{ mm}$ for screws $d = 8 \text{ mm}$.

The axial capacity of a threaded rod or screw shall fulfil the following condition:

$$\frac{F_{ax,d}}{F_{ax,Rd}} \leq 1$$

where: $F_{ax,Rd}$ Minimum of the design values of the withdrawal capacity and the tensile capacity of the reinforcing rods or screws. The effective penetration length is 50 % of the threaded length.

Outside reinforced areas (shaded area in Figure E.1) the shear design shall fulfil the conditions for unreinforced members.

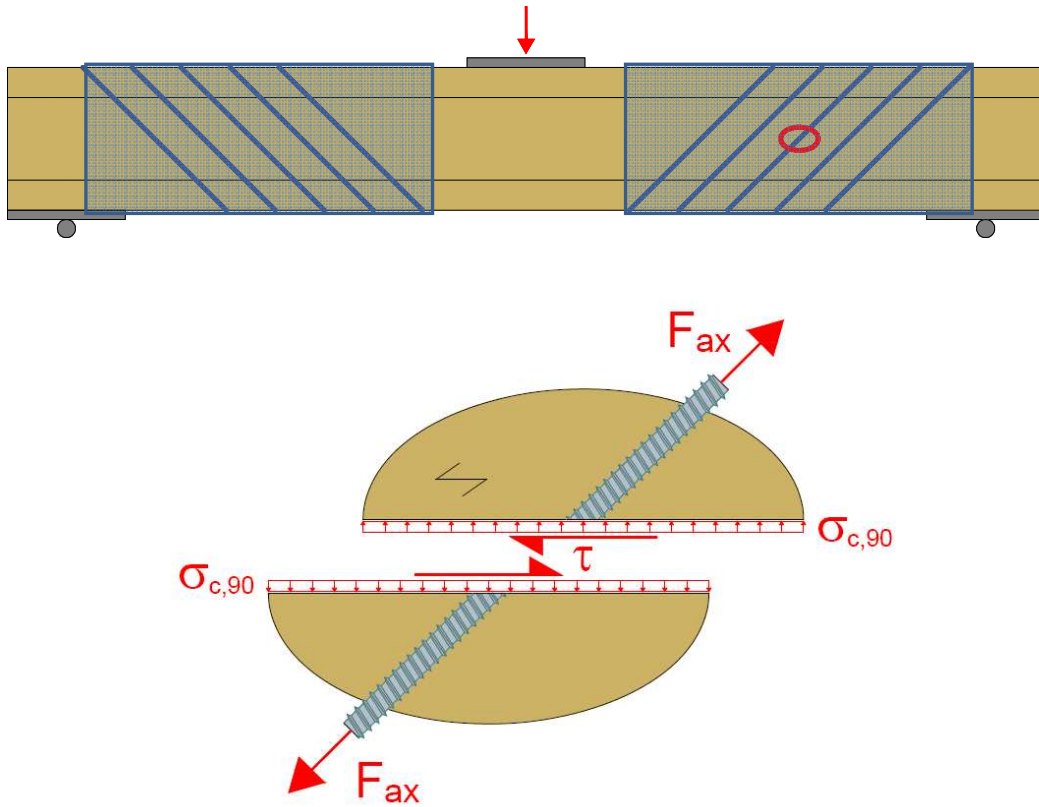

Figure E.1: Timber member with shear reinforcement; shaded areas: reinforced areas

Annex F

Thermal insulation material on top of rafters

SPAX screws with an outer thread diameter $6 \text{ mm} \leq d \leq 12 \text{ mm}$ may be used for the fixing of Thermal insulation material on top of rafters.

The thickness of the insulation shall not exceed 400 mm. The rafter insulation must be placed on top of solid timber or glued laminated timber rafters and be fixed by battens arranged parallel to the rafters or by wood-based panels on top of the insulation layer. The insulation of vertical facades is also covered by the rules given here.

Screws must be screwed in the rafter through the battens or panels and the insulation without pre-drilling in one sequence.

The angle α between the screw axis and the grain direction of the rafter should be between 30° and 90° .

The rafter consists of solid timber (softwood) according to EN 14081-1, glued laminated timber according to EN 14080, cross-laminated timber, or laminated veneer lumber according to EN 14374 or to European Technical Approval or similar glued members according to European Technical Approval and has a minimum width of 60 mm.

The battens must be from solid timber (softwood) according to EN 338:2003-04. The minimum thickness t and the minimum width b of the battens is given as follows:

Screws $d \leq 8,0 \text{ mm}$:	$b_{\min} = 50 \text{ mm}$	$t_{\min} = 30 \text{ mm}$
Screws $d = 10 \text{ mm}$:	$b_{\min} = 60 \text{ mm}$	$t_{\min} = 40 \text{ mm}$
Screws $d = 12 \text{ mm}$:	$b_{\min} = 80 \text{ mm}$	$t_{\min} = 100 \text{ mm}$

Alternatively to the battens, panels with a minimum thickness of 20 mm from plywood according to EN 636, particleboard according to EN 312, oriented strand board OSB/3 and OSB/4 according to EN 300 or European Technical Approval and solid wood panels according to EN 13353 may be used. This only applies to the system with parallel inclined screws.

The insulation must comply with a European Technical Approval.

Friction forces shall not be considered for the design of the characteristic axial capacity of the screws.

The anchorage of wind suction forces as well as the bending stresses of the battens or the boards, respectively, shall be considered in design. Additional screws perpendicular to the grain of the rafter (angle $\alpha = 90^\circ$) may be arranged if necessary.

The maximum screw spacing is $e_s = 1,75 \text{ m}$.

Thermal insulation material on rafters with parallel inclined screws

Mechanical model

The system of rafter, Thermal insulation material on top of rafter and battens parallel to the rafter may be considered as a beam on elastic foundation. The batten represents the beam, and the Thermal insulation material on top of the rafter the elastic foundation. The minimum compression stress of the Thermal insulation material at 10 % deformation, measured according to EN 826², shall be $\sigma_{(10\%)} = 0,05$ N/mm². The batten is loaded perpendicular to the axis by point loads F_b . Further point loads F_s are from the shear load of the roof due to dead and snow load, which are transferred from the screw heads into the battens.

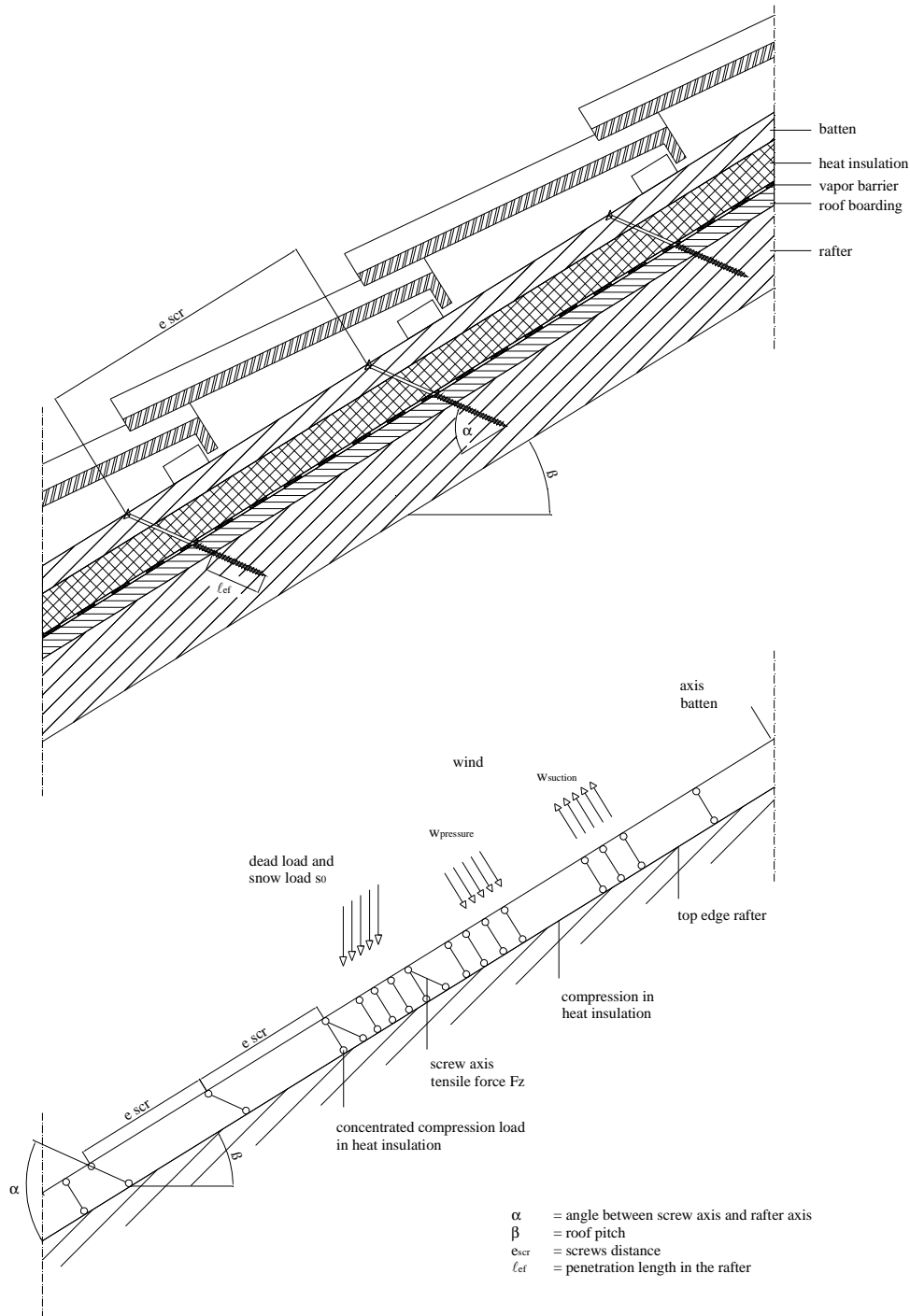

² EN 826:1996

Design of the battens

The bending stresses are calculated as:

$$M = \frac{(F_b + F_s) \cdot \ell_{\text{char}}}{4}$$

Where

$$\ell_{\text{char}} = \text{characteristic length } \ell_{\text{char}} = \sqrt[4]{\frac{4 \cdot EI}{w_{\text{ef}} \cdot K}}$$

EI = bending stiffness of the batten

K = coefficient of subgrade

w_{ef} = effective width of the Thermal insulation material

F_b = Point loads perpendicular to the battens

F_s = Point loads perpendicular to the battens, load application in the area of the screw heads

The coefficient of subgrade K may be calculated from the modulus of elasticity E_{HI} and the thickness t_{HI} of the Thermal insulation material if the effective width w_{ef} of the Thermal insulation material under compression is known. Due to the load extension in the Thermal insulation material the effective width w_{ef} is greater than the width of the batten or rafter, respectively. For further calculations, the effective width w_{ef} of the Thermal insulation material may be determined according to:

$$w_{\text{ef}} = w + t_{\text{HI}} / 2$$

where

w = minimum width of the batten or rafter, respectively

t_{HI} = thickness of the Thermal insulation material

$$K = \frac{E_{\text{HI}}}{t_{\text{HI}}}$$

The following condition shall be satisfied:

$$\frac{\sigma_{\text{m,d}}}{f_{\text{m,d}}} = \frac{M_{\text{d}}}{W \cdot f_{\text{m,d}}} \leq 1$$

For the calculation of the section modulus W the net cross section has to be considered.

The shear stresses shall be calculated according to:

$$V = \frac{(F_b + F_s)}{2}$$

The following condition shall be satisfied:

$$\frac{\tau_{\text{d}}}{f_{\text{v,d}}} = \frac{1,5 \cdot V_{\text{d}}}{A \cdot f_{\text{v,d}}} \leq 1$$

For the calculation of the cross section area the net cross section has to be considered.

Design of the Thermal insulation material

The compressive stresses in the Thermal insulation material shall be calculated according to:

$$\sigma = \frac{1,5 \cdot F_b + F_s}{2 \cdot \ell_{\text{char}} \cdot w}$$

The design value of the compressive stress shall not be greater than 110 % of the compressive stress at 10 % deformation calculated according to EN 826.

Design of the screws

The screws are loaded predominantly axially. The axial tension force in the screw may be calculated from the shear loads of the roof R_s:

$$T_s = \frac{R_s}{\cos \alpha}$$

The load-carrying capacity of axially loaded screws is the minimum design value of the axial withdrawal capacity of the threaded part of the screw, the head pull-through capacity of the screw and the tensile capacity of the screw.

In order to limit the deformation of the screw head for Thermal insulation material thicknesses over 200 mm or with compressive strength below 0,12 N/mm², respectively, the axial withdrawal capacity of the screws shall be reduced by the factors k_1 and k_2 :

$$F_{ax,\alpha,Rd} = \min \left\{ \frac{f_{ax,d} \cdot d \cdot \ell_{ef} \cdot k_1 \cdot k_2}{1,2 \cdot \cos^2 \alpha + \sin^2 \alpha} \cdot \left(\frac{\rho_k}{350} \right)^{0,8}; f_{head,d} \cdot d_h^2 \cdot \left(\frac{\rho_k}{350} \right)^{0,8}; \frac{f_{tens,k}}{\gamma_{M2}} \right\} \text{ for SPAX screws with partial thread}$$

$$F_{ax,\alpha,Rd} = \min \left\{ \begin{array}{l} \frac{f_{ax,d} \cdot d \cdot \ell_{ef} \cdot k_1 \cdot k_2}{1,2 \cdot \cos^2 \alpha + \sin^2 \alpha} \cdot \left(\frac{\rho_k}{350} \right)^{0,8} \\ \max \left\{ f_{head,d} \cdot d_h^2; \frac{f_{ax,d} \cdot d \cdot \ell_{ef,b} \cdot k_1 \cdot k_2}{1,2 \cdot \cos^2 \alpha + \sin^2 \alpha} \right\} \cdot \left(\frac{\rho_k}{350} \right)^{0,8} \\ \frac{f_{tens,k}}{\gamma_{M2}} \end{array} \right\} \text{ for SPAX screws with full thread}$$

where:

- $f_{ax,d}$ design value of the axial withdrawal parameter of the threaded part of the screw in the rafter or batten, $f_{ax,d}$ does not apply for wood-based panels except plywood, LVL or solid wood panels
- d outer thread diameter of the screw, (d_1 in the drawings in the annex)
- ℓ_{ef} Point side penetration length of the threaded part of the screw in the rafter, $\ell_{ef} \geq 40$ mm
- $\ell_{ef,b}$ Length of the threaded part in the batten including the head for tensile and excluding the head for compressive force [mm]
- α Angle between grain and screw axis ($\alpha \geq 30^\circ$)
- ρ_k characteristic density of the wood-based member [kg/m³]
- $f_{head,d}$ design value of the head pull-through capacity of the screw
- d_h head diameter(d_k in the drawings in the annex)
- $f_{tens,k}$ characteristic tensile capacity of the screw
- γ_{M2} partial factor according to EN 1993-1-1 or to the particular national annex
- k_1 $\min \{1; 220/t_{HI}\}$
- k_2 $\min \{1; \sigma_{10\%}/0,12\}$
- t_{HI} thickness of the Thermal insulation material [mm]
- $\sigma_{10\%}$ compressive stress of the Thermal insulation material under 10 % deformation [N/mm²]

If equation k_1 and k_2 are considered, the deflection of the battens does not need to be considered. Alternatively to the battens, panels with a minimum thickness of 20 mm from plywood according to EN 636 or an ETA or national provisions that apply at the installation site, particle board according to EN 312 or an ETA or national provisions that apply at the installation site, oriented strand board according to EN 300 or an ETA or national provisions that apply at the installation site and solid wood panels according to EN 13353 or an ETA or national provisions that apply at the installation site or cross laminated timber according to an ETA may be used.

Thermal insulation material on rafters with alternatively inclined screws

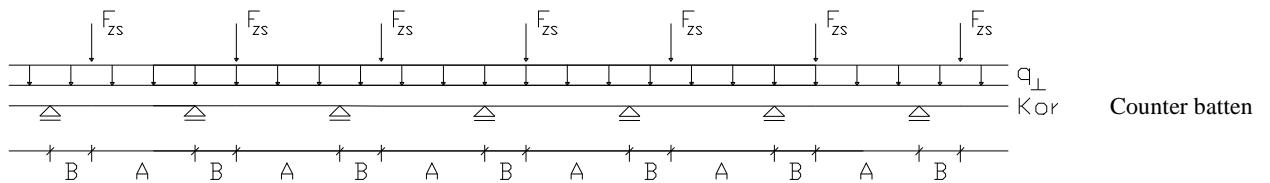
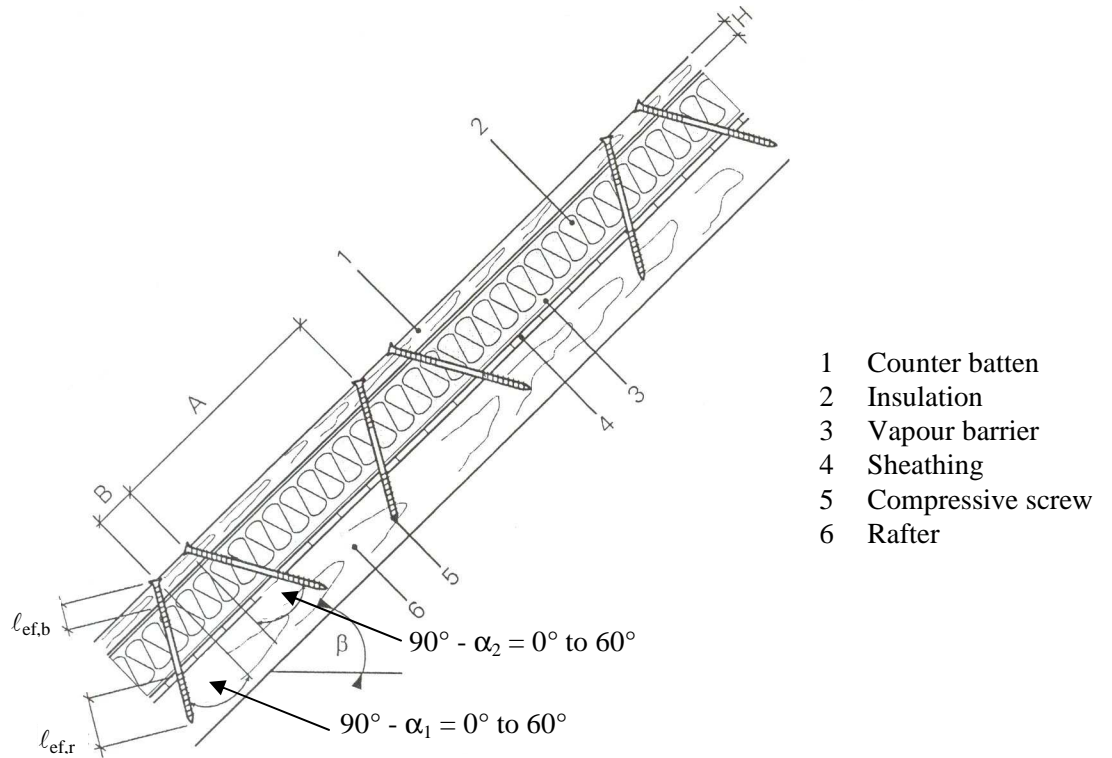

Mechanical model

Depending on the screw spacing and the arrangement of tensile and compressive screws with different inclinations the battens are loaded by significant bending moments. The bending moments are derived based on the following assumptions:

- The tensile and compressive loads in the screws are determined based on equilibrium conditions from the actions parallel and perpendicular to the roof plane. These actions are constant line loads q_{\perp} and q_{\parallel} .
- The screws act as hinged columns supported 10 mm within the batten or rafter, respectively. The effective column length consequently equals the length of the screw between batten and rafter plus 20 mm.
- The batten is considered as a continuous beam with a constant span $\ell = A + B$. The compressive screws constitute the supports of the continuous beam while the tensile screws transfer concentrated loads perpendicular to the batten axis.

The screws are predominantly loaded in withdrawal or compression, respectively. The screw's normal forces are determined based on the loads parallel and perpendicular to the roof plane:

Compressive screw:
$$F_{c,Ed} = (A + B) \cdot \left(-\frac{q_{\parallel}}{\cos \alpha_1 + \sin \alpha_1 / \tan \alpha_2} - \frac{q_{\perp} \cdot \sin(90^\circ - \alpha_2)}{\sin(\alpha_1 + \alpha_2)} \right)$$

Tensile screw:
$$F_{t,Ed} = (A + B) \cdot \left(\frac{q_{\parallel}}{\cos \alpha_2 + \sin \alpha_2 / \tan \alpha_1} - \frac{q_{\perp} \cdot \sin(90^\circ - \alpha_1)}{\sin(\alpha_1 + \alpha_2)} \right)$$

The bending moments in the batten follow from the constant line load q_{\perp} and the load components perpendicular to the batten from the tensile screws. The span of the continuous beam is $(A + B)$. The load component perpendicular to the batten from the tensile screw is:

$$F_{ZS,Ed} = (A + B) \cdot \left(\frac{q_{\parallel}}{1/\tan \alpha_1 + 1/\tan \alpha_2} - \frac{q_{\perp} \cdot \sin(90^{\circ} - \alpha_1) \cdot \sin \alpha_2}{\sin(\alpha_1 + \alpha_2)} \right)$$

Where:

- q_{\parallel} Constant line load parallel to batten
- q_{\perp} Constant line load perpendicular to batten
- α_1 Angle between compressive screw axis and grain direction
- α_2 Angle between tensile screw axis and grain direction

A positive value for F_{ZS} means a load towards the rafter, a negative value a load away from the rafter.

Design of the screws

The load-carrying capacity of the screws shall be calculated as follows:

Screws loaded in tension:

$$F_{ax,\alpha,Rd} = \min \left\{ \frac{f_{ax,d} \cdot d \cdot \ell_{ef,b}}{1.2 \cdot \cos^2 \alpha_2 + \sin^2 \alpha_2} \cdot \left(\frac{\rho_{b,k}}{350} \right)^{0.8}; \frac{f_{ax,d} \cdot d \cdot \ell_{ef,r}}{1.2 \cdot \cos^2 \alpha_2 + \sin^2 \alpha_2} \cdot \left(\frac{\rho_{r,k}}{350} \right)^{0.8}; \frac{f_{tens,k}}{\gamma_{M2}} \right\}$$

Screws loaded in compression:

$$F_{ax,\alpha,Rd} = \min \left\{ \frac{f_{ax,d} \cdot d \cdot \ell_{ef,b}}{1.2 \cdot \cos^2 \alpha_1 + \sin^2 \alpha_1} \cdot \left(\frac{\rho_{b,k}}{350} \right)^{0.8}; \frac{f_{ax,d} \cdot d \cdot \ell_{ef,r}}{1.2 \cdot \cos^2 \alpha_1 + \sin^2 \alpha_1} \cdot \left(\frac{\rho_{r,k}}{350} \right)^{0.8}; \frac{\kappa_c \cdot N_{pl,k}}{\gamma_{M1}} \right\}$$

where:

- $f_{ax,d}$ design value of the axial withdrawal parameter of the threaded part of the screw in the rafter or batten, $f_{ax,d}$ does not apply for wood-based panels except plywood, LVL or solid wood panels
- d outer thread diameter of the screw, (d_1 in the drawings in the annex)
- $\ell_{ef,b}$ penetration length of the threaded part of the screw in the batten
- $\ell_{ef,r}$ penetration length of the threaded part of the screw in the rafter, $\ell_{ef} \geq 40$ mm
- ρ_{bk} characteristic density of the batten [kg/m^3]
- ρ_{rk} characteristic density of the rafter [kg/m^3]
- α angle α_1 (compression) or α_2 (tension) between screw axis and grain direction, $30^{\circ} \leq \alpha_1 \leq 90^{\circ}$, $30^{\circ} \leq \alpha_2 \leq 90^{\circ}$
- $f_{tens,k}$ characteristic tensile capacity of the screw
- γ_{M1}, γ_{M2} partial factor according to EN 1993-1-1 or to the particular national annex
- $\kappa_c \cdot N_{pl,k}$ Buckling capacity of the screw

Free screw length [mm]	Carbon steel				Stainless steel	
	6,0 mm	8,0 mm	10,0 mm	12,0 mm	10,0 mm	12,0 mm
	$\kappa_c \cdot N_{pl,k}$ [kN]	$\kappa_c \cdot N_{pl,k}$ [kN]	$\kappa_c \cdot N_{pl,k}$ [kN]	$\kappa_c \cdot N_{pl,k}$ [kN]	$\kappa_c \cdot N_{pl,k}$ [kN]	$\kappa_c \cdot N_{pl,k}$ [kN]
≤ 100	1,12	2,79	6,09	12,0	5,22	9,68
120	0,85	2,12	4,68	9,39	4,16	7,97
140	0,66	1,66	3,70	7,50	3,36	6,58
160	0,53	1,34	2,99	6,10	2,76	5,48
180	0,43	1,10	2,48	5,06	2,30	4,62
200		0,92	2,07	4,26	1,94	3,93
220		0,78	1,76	3,65	1,66	3,38
240		0,67	1,51	3,14	1,44	2,94
260		0,58	1,32	2,73	1,26	2,58
280		0,51	1,15	2,40	1,11	2,28
300		0,45	1,02	2,13	0,98	2,02
320		0,40	0,91	1,90	0,88	1,82
340		0,36	0,82	1,70	0,79	1,63
360		0,32	0,73	1,53	0,71	1,48
380		0,29	0,67	1,39	0,65	1,34
400		0,26	0,61	1,27	0,59	1,22
420		0,24	0,55	1,16	0,54	1,12
440		0,22	0,51	1,06	0,49	1,03
460		0,20	0,47	0,98	0,46	0,95
480		0,19	0,43	0,91	0,42	0,88